

Dual

Download from www.dual.de  
Not for commercial use

Edition May 1973

# Dual 1211 Service Manual

1211



## Technical data

Line frequency:	alternating, 50 or 60 cycle, with appropriate motor pulleys
Line voltage:	selector for 110 or 220 volts
Drive:	2-pole Dual single-phase induction motor or 4-pole asynchronous motor with radialelastic suspension
Power consumption:	10 watts approximately at 220 V, 50 cycle
Current requirements:	60 ma. maximum at 220 V, 50 cycle 115 ma. maximum at 117 V, 60 cycle
Turntable speeds:	33 1/3, 45 and 78 r.p.m.
Speed adjustment:	adjustment of 1 semitone (6 %) at all three turntable speeds
Turntable:	weight 3.2 lbs., dia 10 5/8"
Wow and flutter:	less than $\pm 0.17$ %
Rumble:	less than 35 dB below signal level } in accordance with
Signal-to-noise ratio:	less than 55 dB below signal level } DIN 45 500
Tonearm:	torsionally rigid, tubular metal arm with vertical needle bearings, horizontal ball bearings. Min. stylus force: 3 p
Cartridge holder:	removable, suitable for acceptance of cartridges having 1/2" mounting and possessing a weight of 1 - 8 grams
Weight:	9.7 lbs. without packing
Dimensions and mounting cutouts:	see installation instructions

**Dual Gebrüder Steidinger · 7742 St. Georgen/Schwarzwald**

Fig. 1 Tonearm hookup schematic

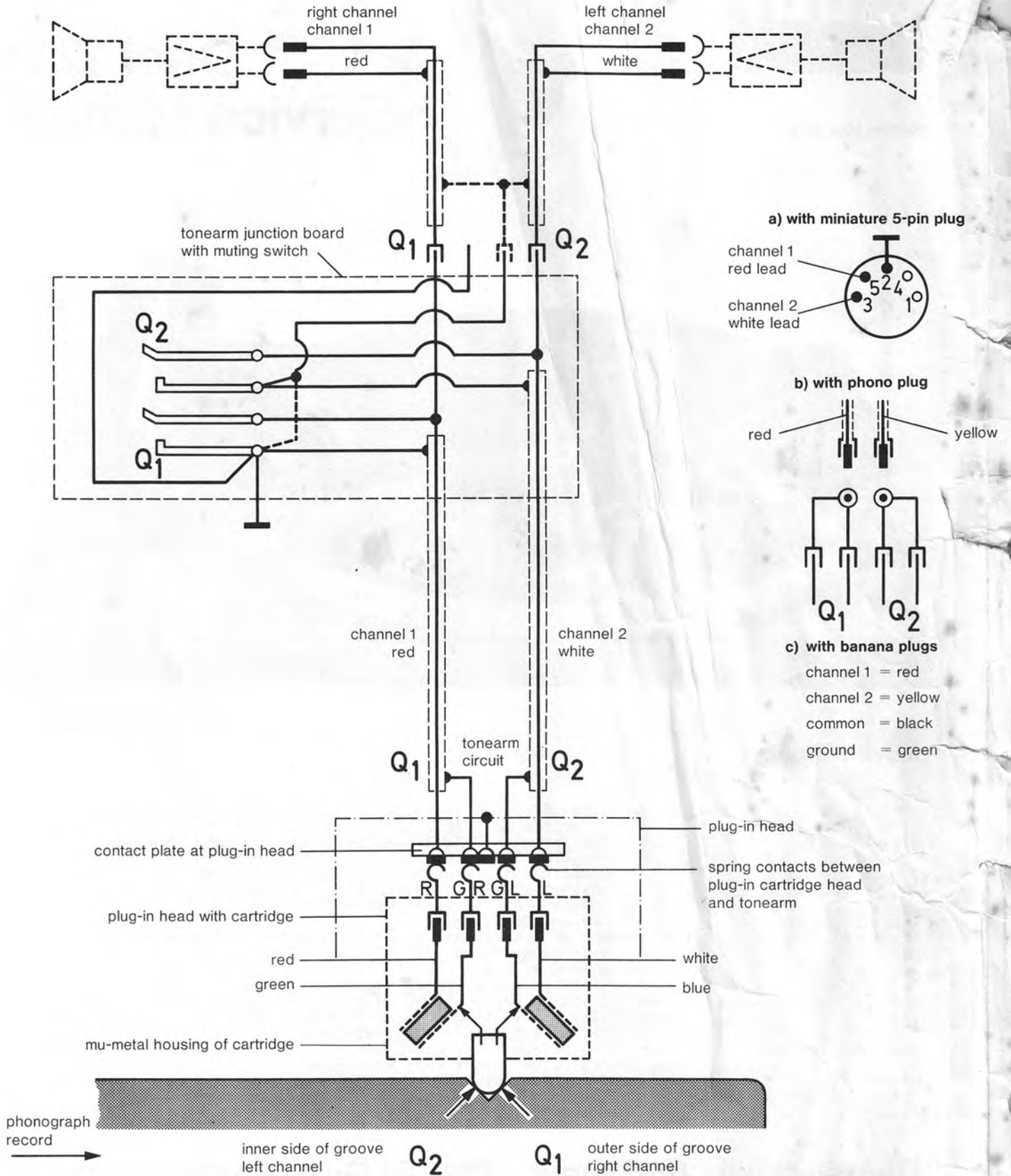

# Contents

	Seite
Technical data	1
Tonearm hookup schematic	2
Motor and drive	4
Pitch Control	5
Turntable does not turn when unit is plugged in and "start" switch operated	5
Turntable does not come up to speed	5
Rumble in reproduction	5
Correct nominal speed obtained only at extreme settings of pitch control	5
The tonearm and its suspension	6
Instructions to replace the complete tonearm and bearing assembly	6
Replacement of tonearm	6
Tonearm head is not parallel to turntable platter	7
Stylus skips	7
Tonearm sets down beside tonearm rest	7
Horizontal pivot friction too high	7
Vertical movement of tonearm is impeded during set-down cycle	7
Tonearm movements	8
Tonearm lift (cue control)	8
Tonearm misses edge of record	9
Tonearm strikes record during change cycle	9
Tonearm does not move onto record when drop cycle is started	9
Tonearm lowers too quickly when drop cycle is started	9
Tonearm returns to rest immediately after being placed on record manually	9
Start cycle	9
Manual start	10
Stop switching	10
Muting switch	11
Record drop	11
Shut-off and change cycle	11
Shut-off mechanism	12
Turntable stops after automatic setdown of the tonearm	12
Last record keeps repeating	12
Record does not drop when unit is switched to "start"	13
Record drops when unit is switched to "stop"	13
Records do not drop	13
Switch latches into "stop" position when tonearm is at rest	14
During change, stop and start operations, noises from the mechanism can be heard in system speaker	14
No sound	14
Motor will not shut-off when tonearm is on arm rest	14
Acoustic feedback	14
Lubrication	15
Replacement parts and exploded views	16-22

Fig. 2 Motor suspension and turntable drive

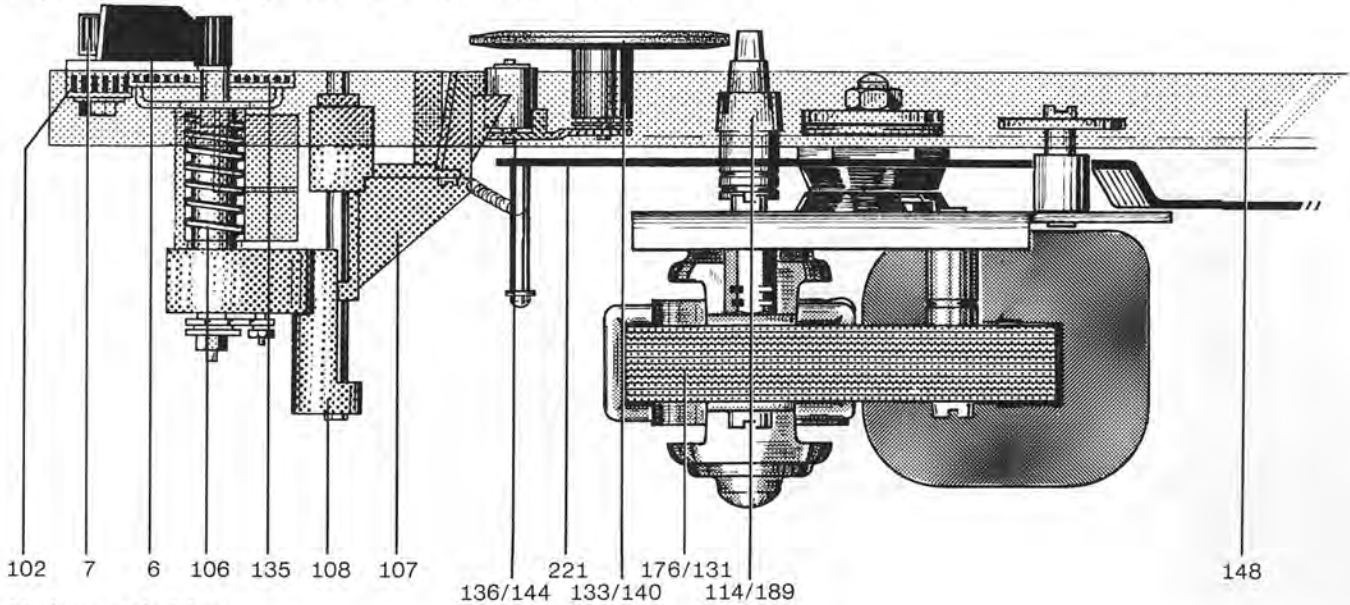

**Motor and drive**

The turntable platter and the mechanism are driven by either a 4-pole (131) or a 2-pole (176) induction motor. Both motors have a balanced armature, polished bearing surfaces and are guaranteed vibration-free. The 4-pole motor has the additional advantage of a very small stray magnetic field.

The speed of the motors is constant over a supply voltage range of  $\pm 10\%$ . Deviations in speed depend on, and are proportional to, line frequency. Adaptation of the motor to 50 or 60 Hz power is accomplished by changing the motor pulley (114/189).

**2-pole motor:**

pulley for 50 Hz part no. 212 135  
 pulley for 60 Hz part no. 212 136

**4-pole motor:**

pulley for 50 Hz part no. 220 970  
 pulley for 60 Hz part no. 220 971

The motor pulley is secured to the motor shaft by a setscrew. When a pulley is replaced or exchanged, it must be set at the correct height (see Figs. 5 and 6).

The turntable platter is driven by the idler wheel (133/140) which is automatically disengaged from the motor pulley when the unit is shut-off, in order to protect its driving surface.

Turntable speeds of  $33 \frac{1}{3}$ , 45, 78 rpm are selected by raising or lowering the idler wheel (133/140) to the appropriate step on the motor pulley.

When the selector lever (6) is moved, the selector segment (105) rotates. This causes the lever (107) fitted in the slot of the selector segment to move in a vertical direction. The idler wheel (133/140) mounted on the swinging arm (135/144) is lifted off the motor pulley and set down again on the motor pulley step for the adjacent speed.

Fig. 3 Motor field connections (less voltage selector)

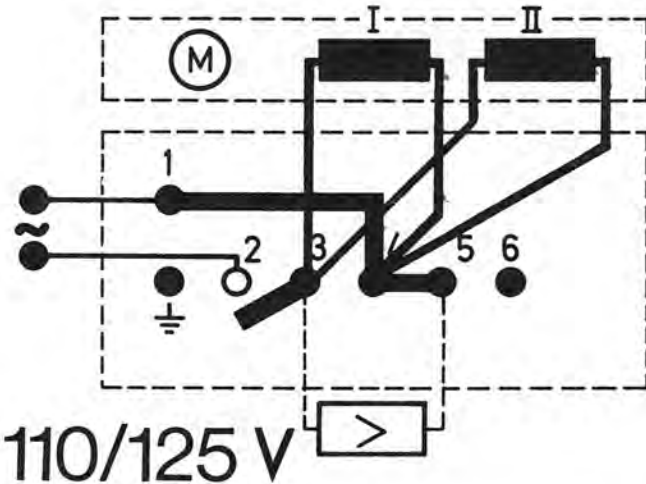
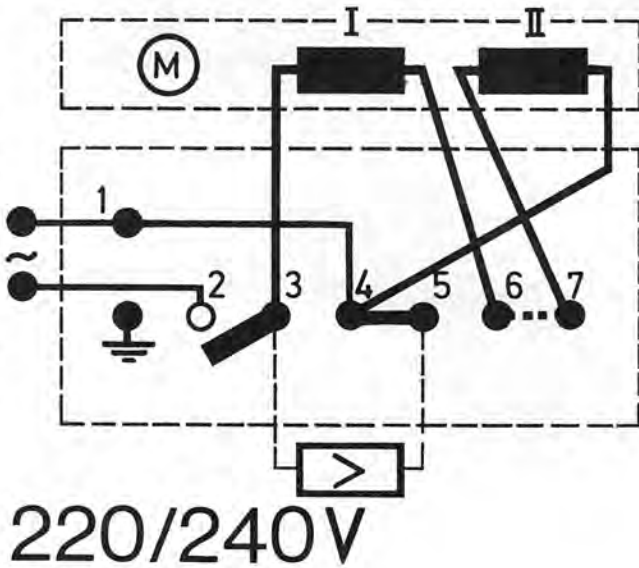

Fig. 4 Motor field connections (with voltage selector)



220/240V

## Pitch Control

For turntable speeds 33 1/3, 45 and 78 rpm, the unit incorporates a voltage-independent pitch control, which permits a turntable speed variation of up to 6% (approximately one semitone).

When the pitch control knob (7) is turned, the switch segment (105) and the switch lever (107) attached to it are moved up or down. This vertical displacement changes the position of the idler wheel on whatever step of the motor pulley it has been placed on (by the speed selector), and, due to the tapered shape of the pulley, effects approximately  $\pm 3\%$  variation in speed.

Fig. 5 Motor pulley position (2-pole motor)

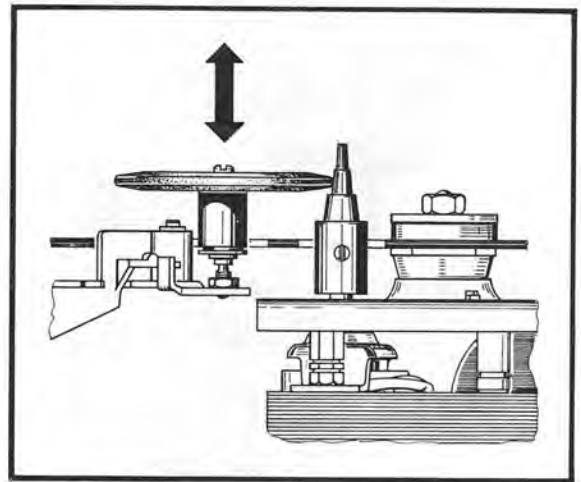

Symptom	Cause	Remedy
Turntable does not run when unit is plugged in and start switch operated	a) Current path to motor interrupted	a) Check connection at switch plate and voltage selector
	b) Idler wheel (133/140) not in contact with platter	b) Check switch lever assembly (107)
	c) Motor pulley loose	c) Tighten motor pulley
Turntable does not come up to speed	a) Motor pulley is not correct for local line frequency	a) Change motor pulley
	b) Slippage between idler wheel (133/140) and motor pulley or platter	b) Clean friction surfaces of idler wheel, motor pulley and turntable platter. If necessary, replace drive wheel. Once the drive surface of the platter has been cleaned, do not touch it with your fingers
	c) Excessive friction in motor, drive wheel or platter bearings	c) Clean and oil bearings
Rumble in reproduction	Worn idler wheel	Replace idler wheel (133/140) and clean platter drive surface and motor pulley with greaseless solvent. Once surface are cleaned, do not touch them with your fingers.

### Symptom

Correct nominal speed obtained only at extreme settings of pitch control

### Cause

Idler wheel does not contact motor pulley correctly

### Remedy

- 4-pole motor  
Loosen setscrew (115) and by means of setscrew (113) adjust the motor pulley on the motor shaft so that when the fine speed adjustment knob is in the center of its range, the idler wheel is positioned in the center of the appropriate motor pulley step. (Fig. 6). When adjustment is completed, tighten setscrew (115).
- 2-pole motor  
After loosening locknut (143), correct the idler wheel position by turning its shaft (142) so that when the fine speed adjustment knob (7) is in the center of its range, the idler wheel is centered in the appropriate step of the motor pulley (Fig. 5). After adjustment, tighten locknut.

Fig. 6 Motor pulley position (4-pole motor)

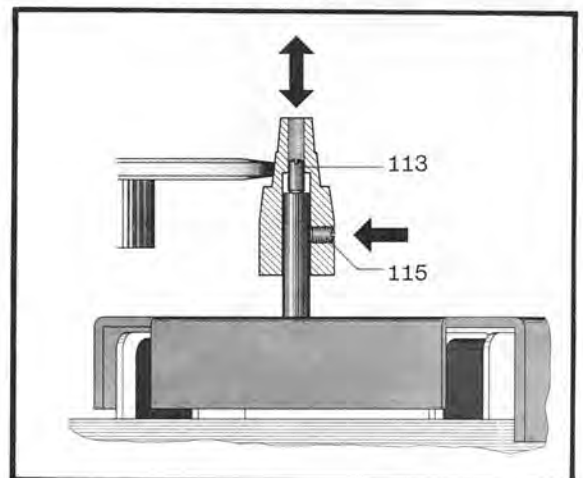
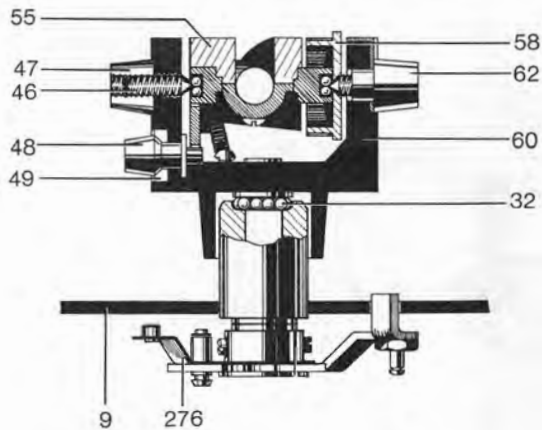

Fig. 7 Tonearm bearing assembly



## The tonearm and its suspension

The tonearm of the Dual 1211 is balanced by springtension, held vertically by needle bearings and horizontally by ball bearings. The tonearm head is removable. Before setting stylus pressure according to the cartridge used, the arm has to be balanced at zero. The tonearm is lifted by turning knurled screw (52) counterclockwise (as seen from the front), and moved down by turning it clockwise. Cartridges between 1 to 8 grams can be balanced, piezo-electric (crystal) cartridges have to be used on units with 2 pole motors. The stylus pressure is changed by turning the numbered springhousing (58), which increases or decreases the tension on the enclosed spring. Pressure can be regulated from 0 to 5.5 grams continuously, minimum pressure 3.0 grams.

## Instructions to replace the complete tonearm and bearing assembly

1. Tighten set in repair-jig, set pressure-dial to zero and lock tonearm in rest.
2. Turn unit upside down and unsolder tonearm leads.
3. Remove main-lever (218) and linking-lever (272).
4. Remove lock-washer (280) and skating-disc (279), remove shut-off slide (278) from eccentric bolt on segment.
5. Loosen cylinder-head screws (274/275) and remove segment (276) with lifting bolt (250).
6. Loosen lock-washer (177), turn unit right-side up and pull the complete tonearm with bearing frame assembly upwards out.

Fig. 8 Tonearm bearing assembly (under view)

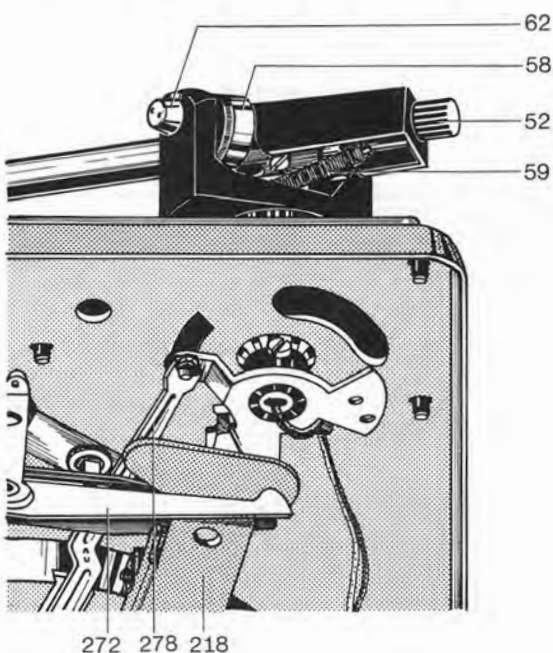

Installation of tonearm complete with bearing frame assembly has to be done in reversed order. The unit is in normal position. Check ball bearings (14 steel-balls 2 mm diameter), insert tonearm complete with bearing frame assembly and lock in rest. With tonearm held in place, turn set upside down, push lock washer (177) into the notch at the shaft of the bearing frame assembly. Put on segment (276). Before tightening screws (274/275), check tonearm position on tonearm rest, which is correct, if tonearm sinks into rest without hesitation.

## Replacement of tonearm

To remove the tonearm from the bearing frame, the pressure dial has to be set at zero, after unsoldering the tonearm leads. Unhook tension spring (59). Remove locknut (47) with threaded rod (46) and bearing screw (62) (left threaded), remove tonearm carefully out of bearing frame.

**Symptom**

Tonearm head is not parallel to turntable platter

**Cause**

Orientation of tonearm head on tonearm tube has altered because of jolting in transport (shipping)

**Remedy**

Remove turntable platter with the help of a screwdriver inserted through the hole in the chassis placed there for the purpose. Loosen screw on tonearm head. After correcting the tonearm head, tighten screw. (Fig. 9)

Fig. 9

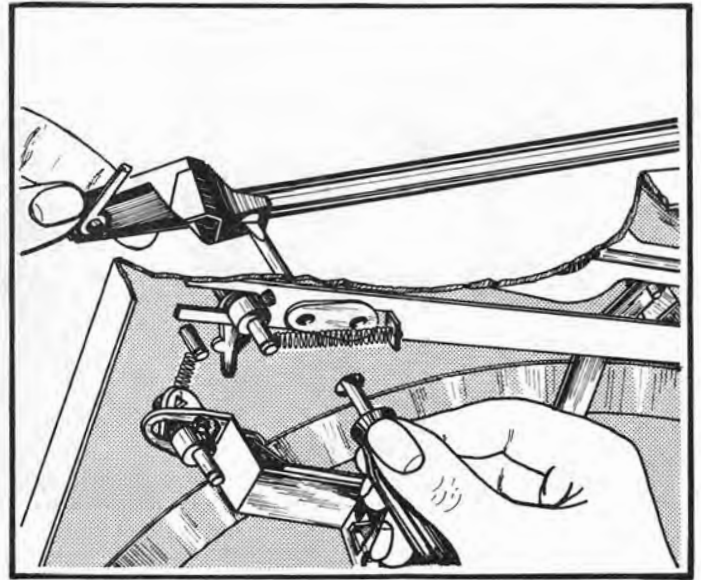

Symptom	Cause	Remedy
Stylus skips	a) Tonearm not balanced	a) Balance tonearm according to operating instructions
	b) Stylus force too low	b) Set stylus force to cartridge manufacturer's recommended value
	c) Stylus worn or chipped	c) Replace stylus
	d) Excessive friction in tonearm bearing	d) Check tonearm horizontal pivot
	e) Ball (255) missing from shut-off rail	e) Replace ball (255)
Tonearm sets down beside tonearm rest	Arm segment (276) incorrectly adjusted	Correct adjustment: Loosen machine screw (274/275) and rotate segment (276) until adjustment is correct, namely when arm lowers onto rest without binding. Tighten screw
Horizontal pivot friction too high	Tonearm is set too high on tonearm lift. Main lever jams against guide pin of lift screw assembly	Stylus should be no farther from record surface than 1/4". Adjust
Vertical movement of tonearm is impeded during set-down cycle	a) Bearing friction too high	a) Check bearing screw (46) and arm balance
	b) Lift screw (250) jams in guide sleeve of arm segment (255)	b) Remove and clean lift screw

Fig. 10 Tonearm guide mechanism

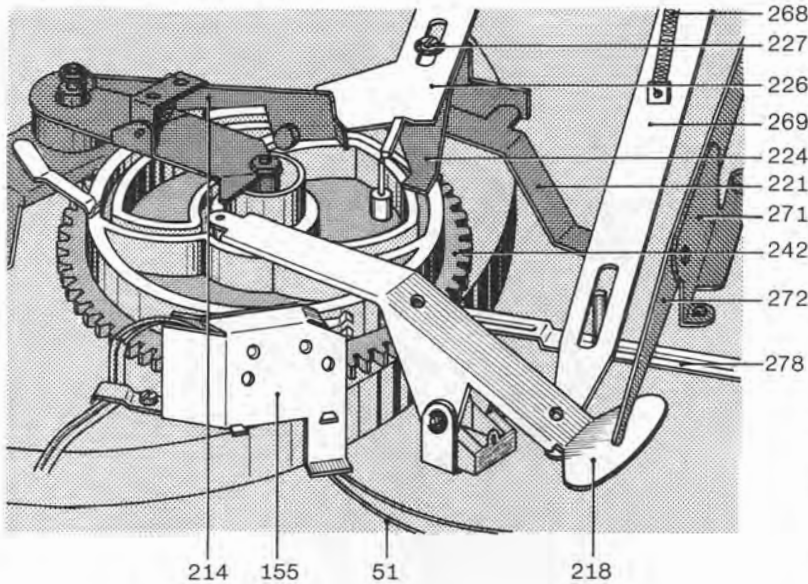

lift and lowering are controlled by the main lever (218) and the lift screw (250). Horizontal movements are controlled by the main lever (218) and the segment (275). Setting the changer for playback of 7", 10" or 12" discs is done with the indexing lever (24). Setdown points are determined by the eccentric portion of the arm positioning slide (269) and the indexing lever (267).

Horizontal movement of the tonearm is limited by the arm segment striking the arm positioning slide (269). During the change cycle, the main lever (218) raises the arm positioning slide, bringing it within reach of the spring stud. On completion of the change cycle (setdown of the tonearm on the record), the arm positioning slide (269) is again released and returns to its normal position. It thus moves out of reach of the spring stud, permitting the tonearm to move horizontally without hindrance, while playing the record.

### Tonearm movements

A guide groove located on the underside of the main cam (242) controls the automatic lift and set-down of the tonearm as the cam rotates through 360°. Tonearm

### Tonearm lift (Cue control)

The tonearm lift permits the tonearm to be set down on the record safely at any desired point except the shut-off area (near the record label).

Pulling the tonearm lift towards the front turns the drive washer (261). This moves the connecting lever (272), main lever (218) and lift screw (250) to raise the tonearm.

After the tonearm is moved (by hand) to the desired spot on the record, the tonearm lift handle is lightly tapped towards the rear to

release the mechanism. The connecting lever (272) and the leaf spring (215) of the main lever (193) are freed, allowing the tonearm to fall. The rate of fall is controlled by silicone grease on the drive washer (261).

The height of the stylus above the record can be varied from zero to about 1/4" by adjusting setscrew (231).

Turning it to the right increases the height, turning it to the left decreases the height.

Fig. 11 Tonearm lift (tonearm raised)

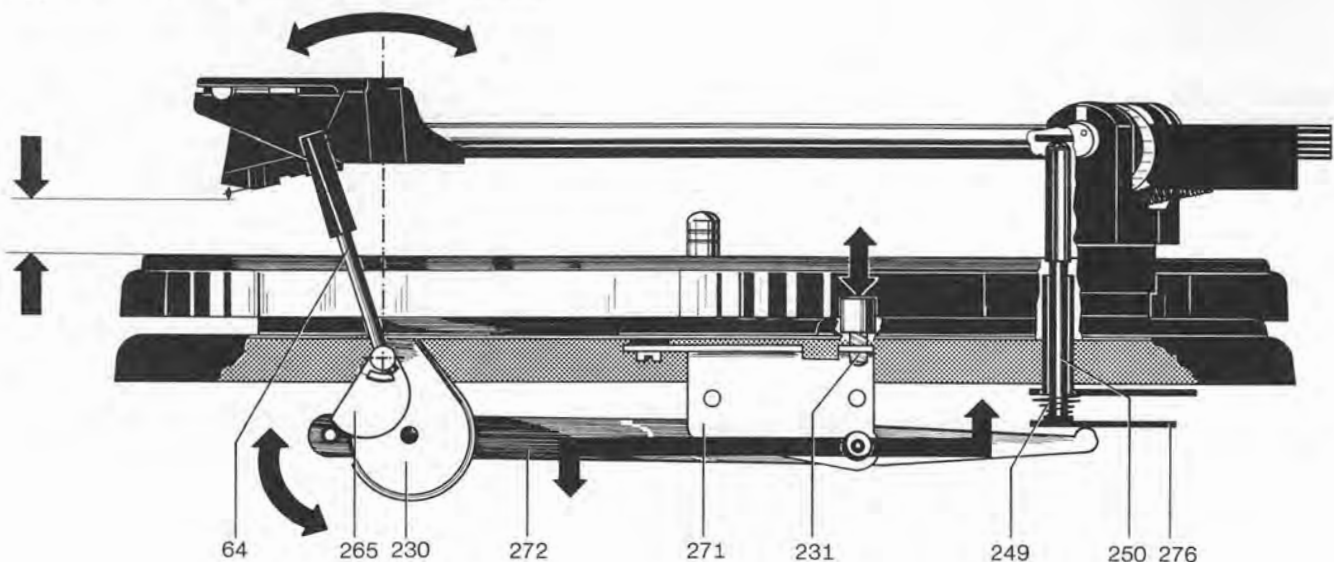



Symptom	Cause	Remedy
Tonearm misses edge of record	a) Set-down incorrectly adjusted	a) Adjust set-down with a 12" record so that stylus touches record approximately 1/16" inside edge of record. Adjustment will be correct for other sizes
	b) Record not standard size	b) Use standard records
	c) Friction surfaces of tonearm clutch dirty	c) Clean clutch surfaces
Tonearm strikes record during change cycle	Tonearm height incorrectly set	Adjust arm height with screw (48). Height is correct when stylus tip is 1/16" to 1/8" above start switch (25) when arm is removed from rest lowered
Tonearm does not move on to record when drop cycle is started	Damping too great, drive washer dirty	Loosen nut (229) and washer (230) and drive washer (261). Clean thoroughly. Coat both sides evenly with silicone grease, re-assemble and wipe off excess
Tonearm lowers too quickly when drop cycle is started	Too little damping	Loosen nut (229) and washer (230) and drive washer (261). Clean thoroughly. Coat both sides evenly with silicone grease, re-assemble and wipe off excess
Tonearm returns to rest immediately after being placed on record manually	Shut-off mechanism has shifted out of position during shipping	Before using changer after moving, run it through start cycle with tonearm locked on rest

## Start cycle

Moving the start switch (25) moves the switch lever (224) towards the main cam (242), initiating the following sequence.

- a) The set screw of the switch lever assembly (224) turns the switch arm (221) mounted on the grooved shaft (227). Via a tension spring, this actuates the rocker assembly (107) and engages the idler (133/140) between the platter (5) and the motor pulley (114/189). At the same time, the power switch (182) is actuated by the switch slide (184) through the switch arm, and the turntable begins to rotate.
- b) The switch lever (224) is brought within reach of the cam follower lever (245), so that it is pushed into the change position after the rotation of the main cam.

Fig. 12 Start position

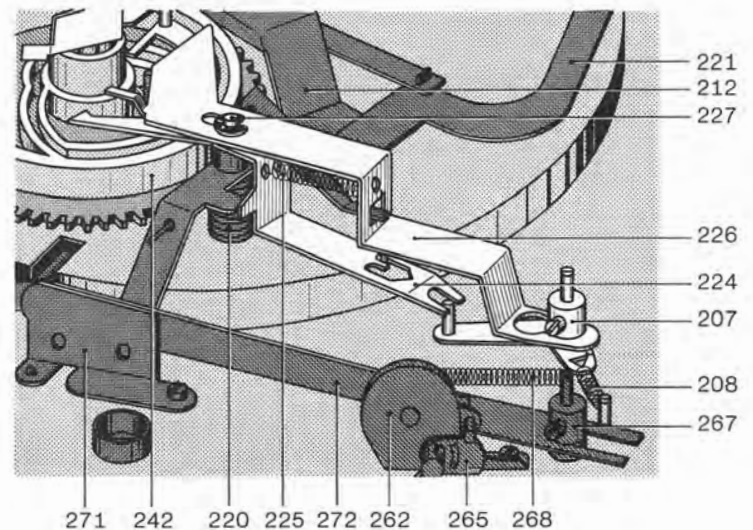
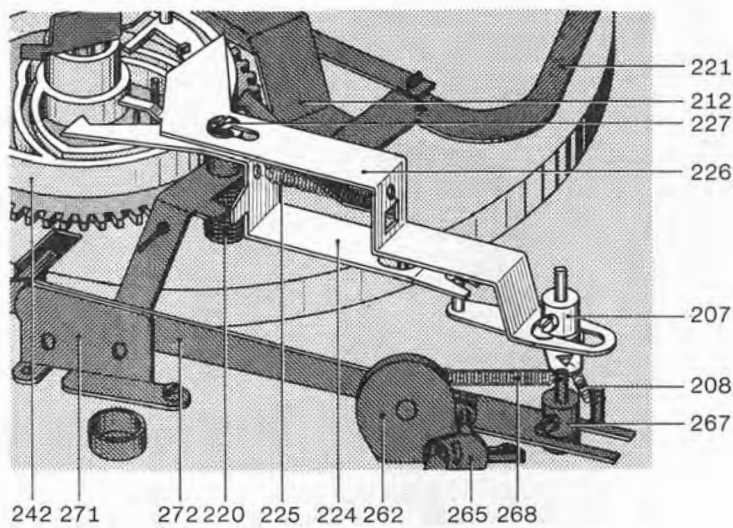

Fig. 13 Stop position



Moving the operating switch also releases the start lever (226), pulling it towards the main cam by means of the tension spring (225). This causes coil spring to bring the shut-off lever (238) within range of the main cam dog. Thus the shut-off lever drives the main cam.

To prevent malfunctioning, the operating switch is locked during the start cycle (that is, while the main cam is turning). Just before the main cam reaches its neutral position (at the end of the change cycle), the start lever is pushed clear of the main cam by the start pin of the main cam. This restores the switch lever and operating switch to their original positions.

After installation and also after moving the changer, the unit should be started with the tonearm locked on the rest. This will automatically re-adjust the shut-off lever, which may have shifted out of position.

### Manual start

When the tonearm (15) is swung inward by hand, the pawl on the switch arm drops into a support on the base plate, holding the switch arm in this position and the idler wheel (133/140) in contact with the platter. The slide (184) linked with the switch arm actuates the power switch and sets the turntable platter rotating.

On reaching the run-out groove, the tonearm automatically returns to its rest position and the unit shuts itself off. (See shut-off mechanism, next side). However, if the tonearm is lifted off the record manually and returned to the rest, the tabs of the arm segment (276) release the pawl. The torsion spring (220) then returns the switch arm to its initial position, opening the power switch and disengaging the idler wheel.

### Stop switching

When the operating lever is moved to "stop", the starting lever (226) is pushed forward. As a result the shut-off linkage comes into contact with the main cam. The swinging lever (245) remains in its stop position.

When the tonearm is on its rest and the operating lever is pushed to "stop", the operating lever must not jam.

Fig. 14 Muting switch

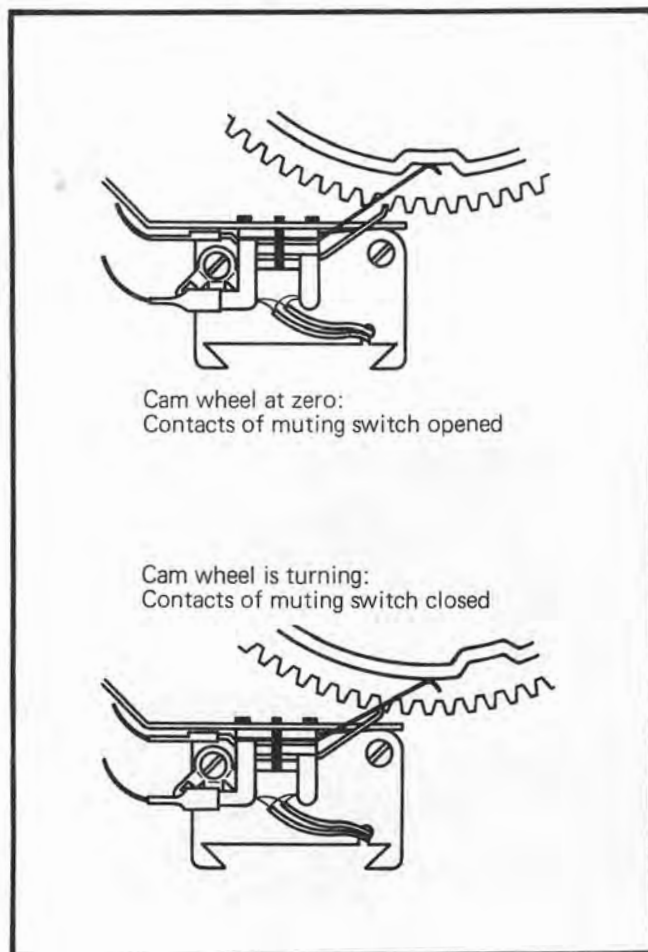

## Muting switch

To prevent the noises of the change cycle from being sent through the audio system, the apparatus is fitted with a short-circuiting (muting) switch (155). The switch springs for both channels are actuated by the main cam (242). In the tonearm rest position, the muting switch is opened.

Fig. 15 Record drop

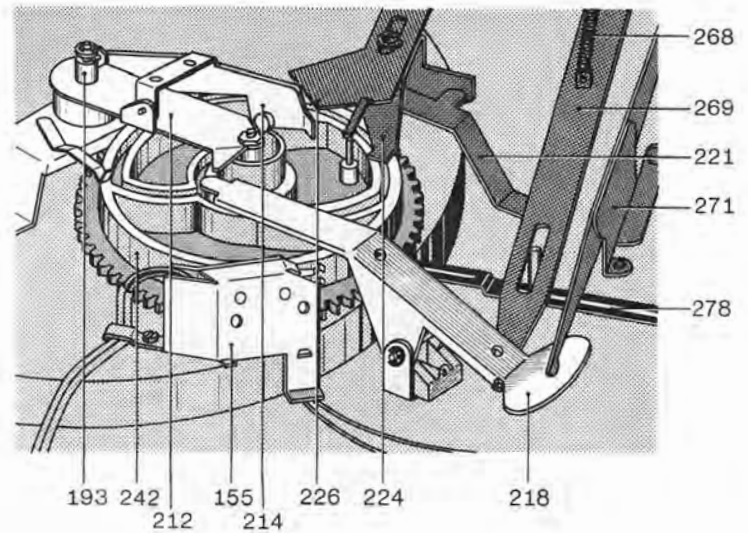

## Record drop

Insert the appropriate spindle - AW 3 for standard records (7 mm center hole) or AS 12 for 45 rpm records (38 mm center hole).

Record-drop is initiated by the rotation of cam, whose cam surface guides the cam rocker, pushing the change actuator stud and releasing a record by means of the automatic spindle. The main cam is designed so that a record can drop only when the tonearm is above the tonearm rest and thus out of the reach of the largest possible records (12" diameter).

Fig. 16 Actuating "change" or "shut-off"

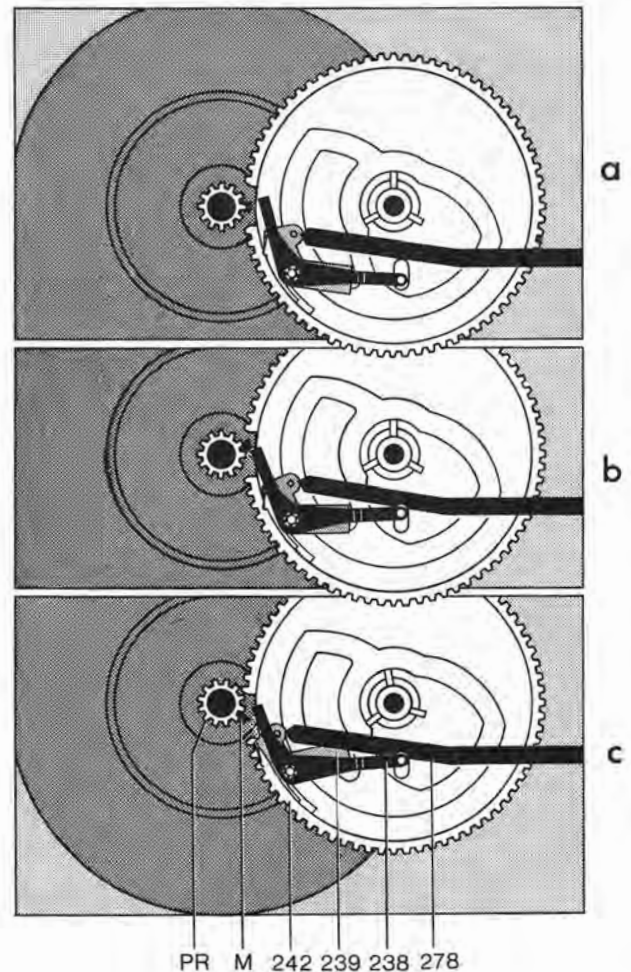

## Shut-off and change cycle

The dog (M) on the turntable platter gear (PR) and the shut-off lever (238) actuate both the change cycle at the end of the record as well as the shut-off after the last record in a stack is played.

At the end of a record, the tonearm moves towards the center at an accelerated rate due to the increased pitch of the grooves. This motion carries the shut-off lever (238) towards the dog by means of the shut-off slide (278). The eccentric dog pushes the shut-off lever (238) back at each revolution as long as the tonearm advance is only one normal record groove.

The run-out groove with its steeper pitch moves the shut-off lever against the dog with greater force, engaging the shut-off lever (238) and causing the main cam (242) to be driven out of its neutral position by the turntable platter gear.

Fig. 17 Change cycle

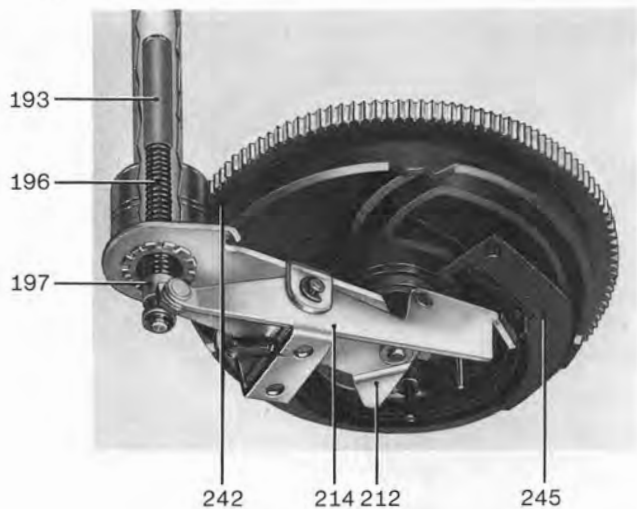

Fig. 18

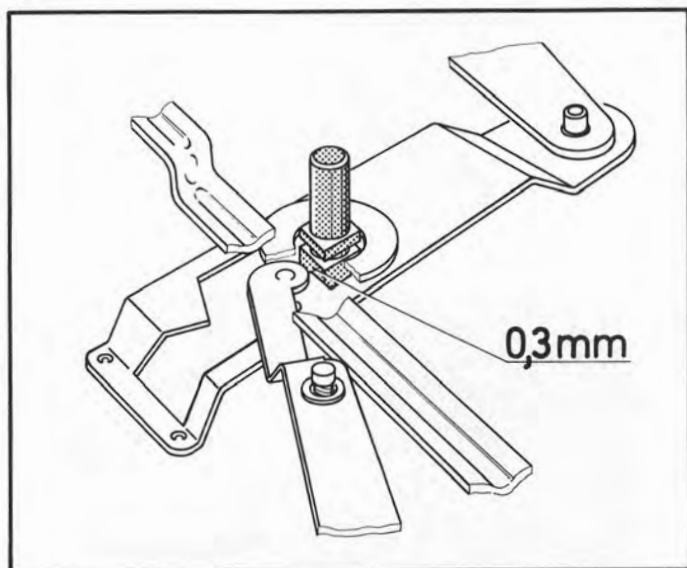
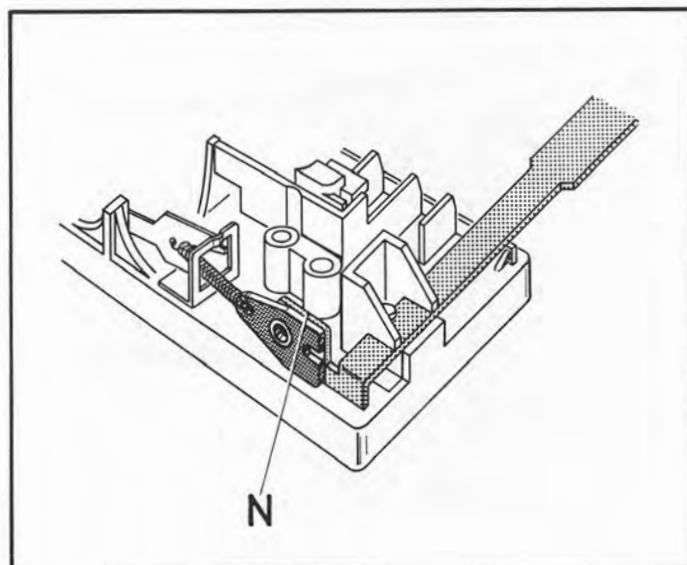

Fig. 19



## Shut-off mechanism

Shut-off and change functions are determined by the position of the cam follower lever (245). After every start or record-drop, the cam follower lever is brought to its stop position by the main lever (218) (longer end towards the center of the main cam). As the record is dropped the cam follower lever (245) is turned to its start position by the cam rocker (214), so that the tonearm can swing in toward the record and be lowered on to it. If there are no more records on the spindle, and the cam rocker cannot turn the cam follower lever, the lever remains in its stop position and allows the tonearm to swing to its rest position.

When the main cam (242) returns to its neutral position, the switch arm (221) drops into a cut-out in the main cam, opening the power switch (182) and disengaging the drive idler (133/140).

### Symptom

Turntable stops after automatic setdown of the tonearm

### Cause

- a) Switch arm (221) is not latched by pawl (234)
- b) Power switch opens

### Remedy

- a) Loosen screw and turn the short arm piece on the long switch-arm piece. Move the tonearm in and turn the main cam to its neutral position and adjust for about 1/64" play between cam and rectangular bolts riveted into the chassis.
- b) As the tonearm moves in, switch slide (184) must overtravel by about 1/64". Its tab must engage the switch.

### Symptom

Last record keeps repeating

### Cause

Defective spindle

### Remedy

Replace spindle

**Symptom**

Record does not drop when unit is switched to "start"

**Cause**

Inadequate engagement between change lever and cam rocker (214)

**Remedy**

Adjust clearance between change lever and cam rocker to  $\frac{1}{64}$ " minimum with apparatus in "start" position.

Fig. 20

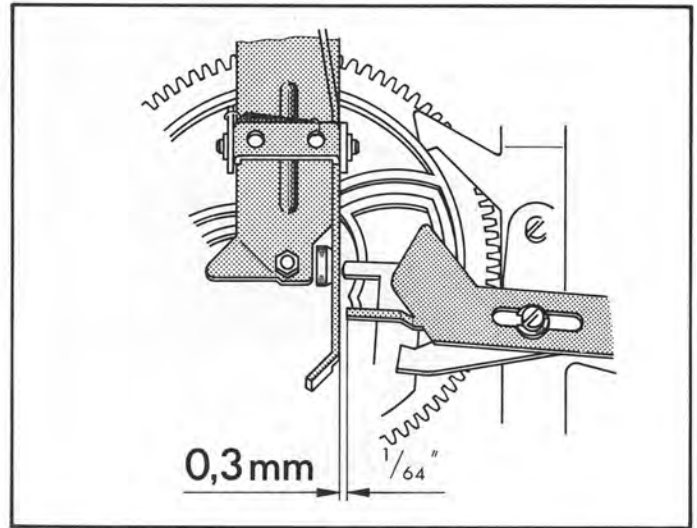

**Symptom**

Record drops when unit is switched to "stop"

**Cause**

Cam rocker (214) not caught by start lever

**Remedy**

Adjust cam rocker so that at the conclusion of the "stop" function the start lever runs about  $\frac{1}{16}$ " under the follower.

Fig. 21

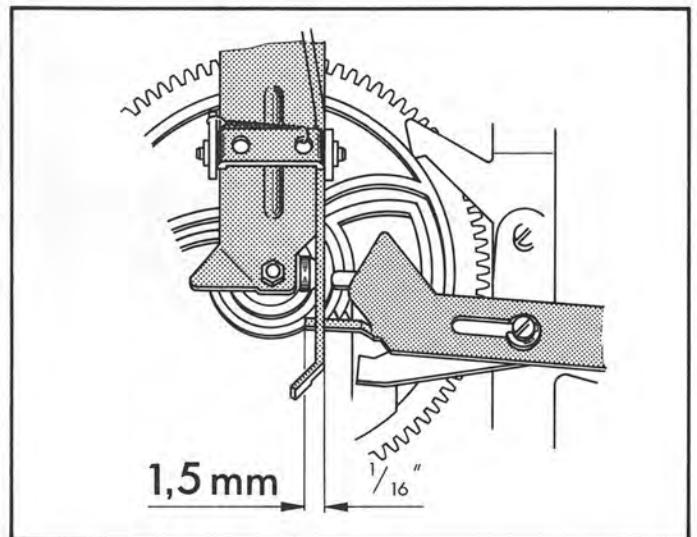

**Symptom**

Records do not drop

**Cause**

Cam rocker (214) has too little force (travel)

**Remedy**

Re-adjust eccentric so that when the three supports in the automatic spindle are held in and the main cam is at its neutral, pressing the change screw moves the support about  $\frac{1}{64}$ ".

Fig. 22

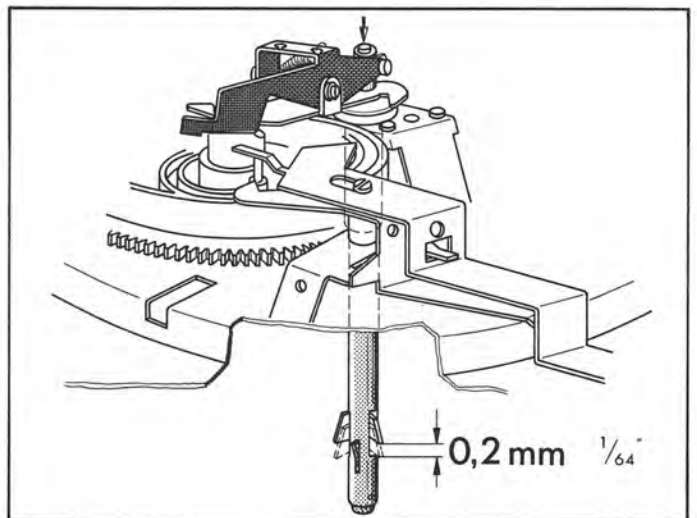
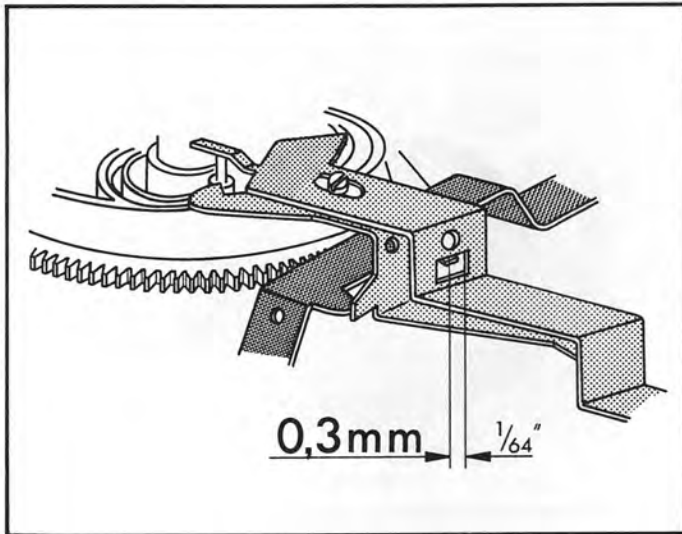

Fig. 23



**Symptom**

Switch latches into "stop" position when tonearm is at rest.

**Cause**

Too much clearance between tab on switch arm (221) and start lever (226).

**Remedy**

Adjust tab on switch arm so that it clears start lever by  $1/64$ " when main cam is in neutral position.

**Symptom**

**Cause**

**Remedy**

During change, stop and start operations, noises from the mechanism can be heard in system speaker

Muting switch misadjusted. Distance between contact springs and shorting contact is too great

Bend contacts so that, in the neutral position of the main cam the spacing between contacts is about 0.02 inch. Clean contacts

No sound

Spacing too small

See above

Motor will not shut off when tonearm is on arm rest

Capacitor across power switch is shorted

Replace capacitor (0.1  $\mu$ F, 700 V)

Acoustic feedback

- a) Chassis parts (for example leads) are touching base cut-out
- b) Connecting cables are too taut

- a) Correct cut-out according to instructions supplied with unit. Move cables
- b) Allow more slack in cables

Fig. 24 Chassis, viewed from above

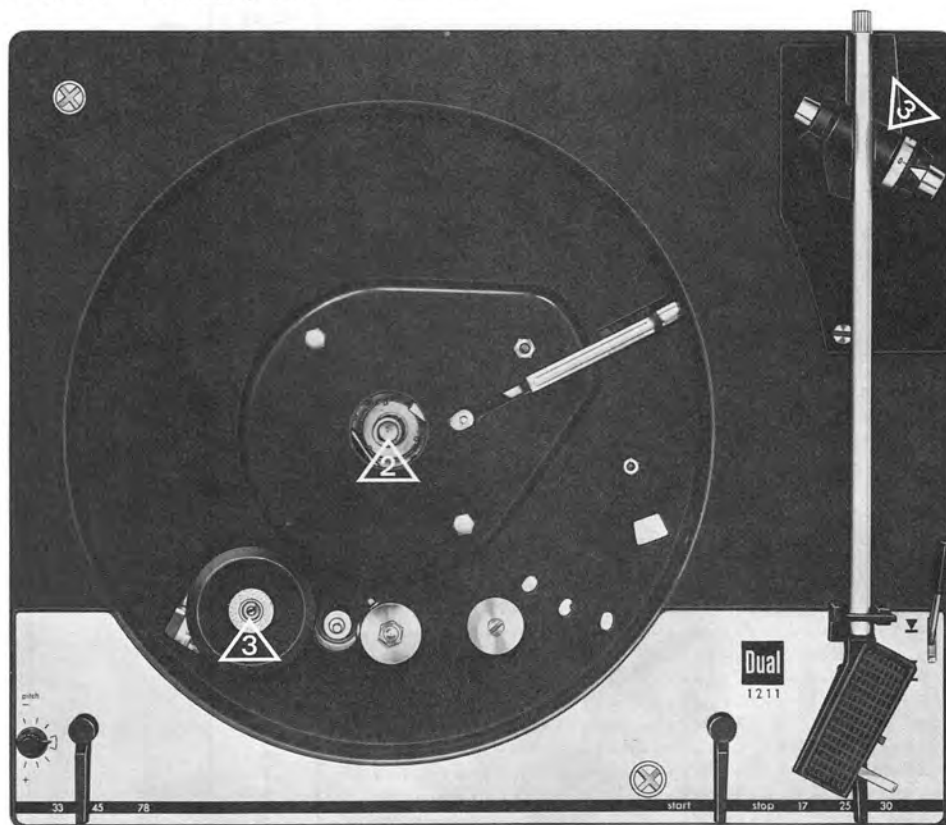

## Lubrication

All bearings and sliding points have been properly lubricated during assembly. Re-lubrication is normally not necessary for about two years since all important bearings are provided with oil retainers and sintered bearings.

Lubrication should be applied sparingly. It is of primary importance that no oil grease should get onto the friction surfaces of the drive wheel, motor pulley or turntable, to avoid slippage. For the same reason, avoid touching these parts.

Use the following lubricants:

Fig. 25 Chassis, viewed from below

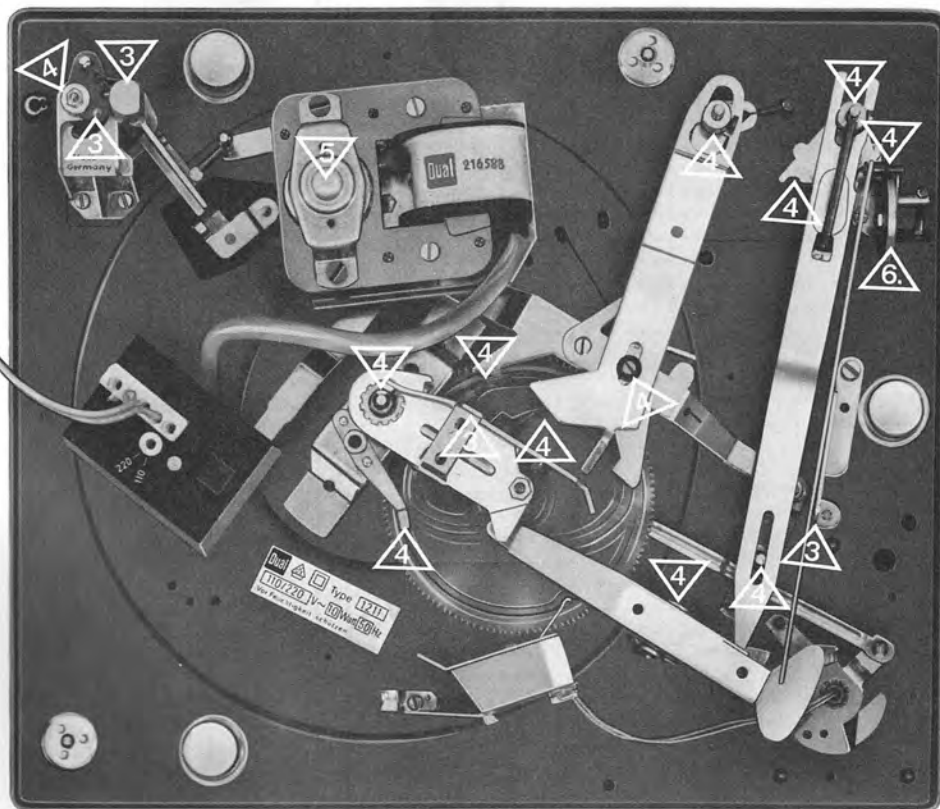





-  Adhesive oil, Renotac No. 342
-  BP oil, Super Visco-static 10 W/30
-  Shell Alvania No. 2
-  Isoflex PDP 40
-  Wacker siliconoil AK 500 000

Fig. 26 Exploded view, parts above chassis

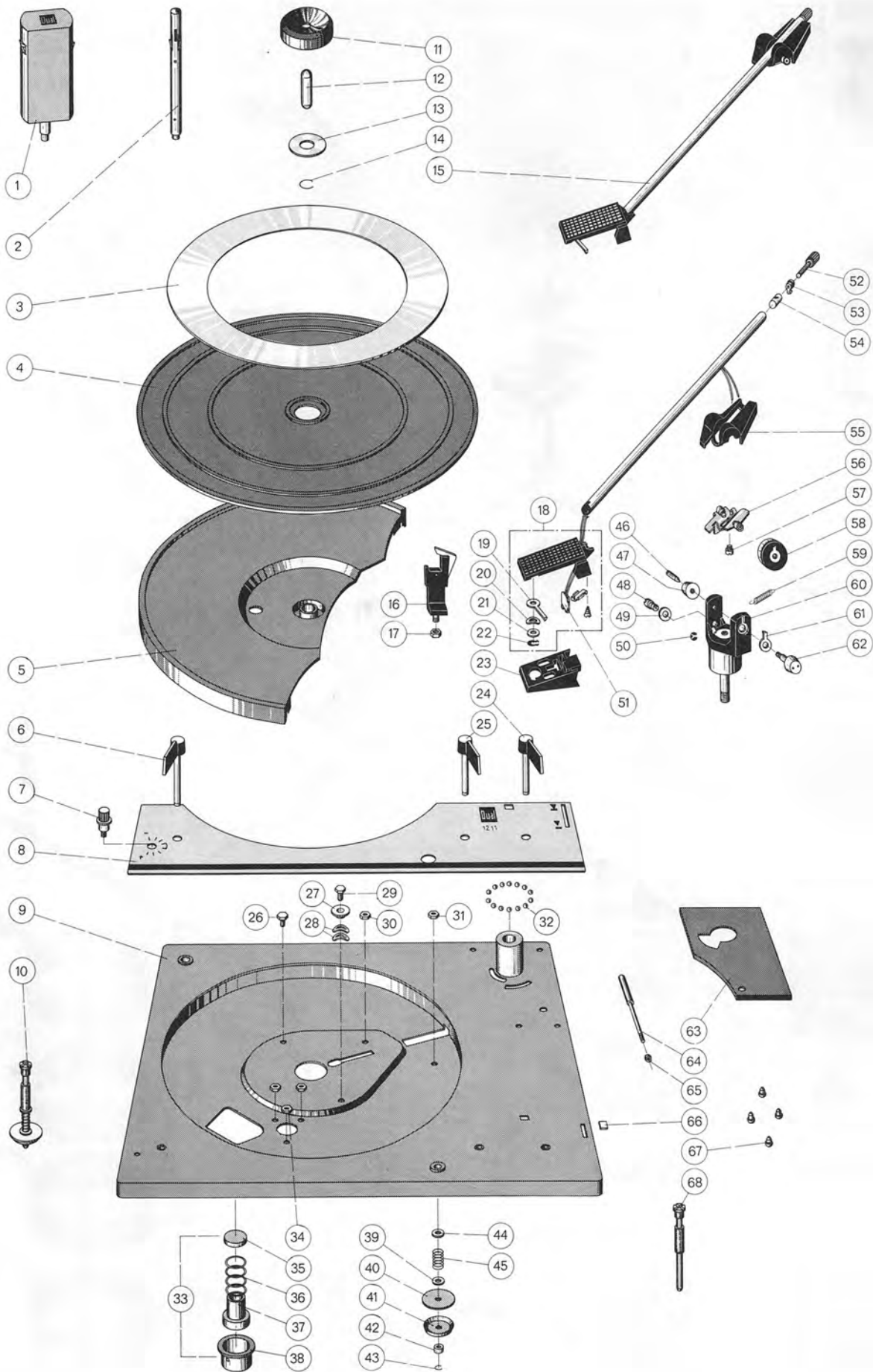
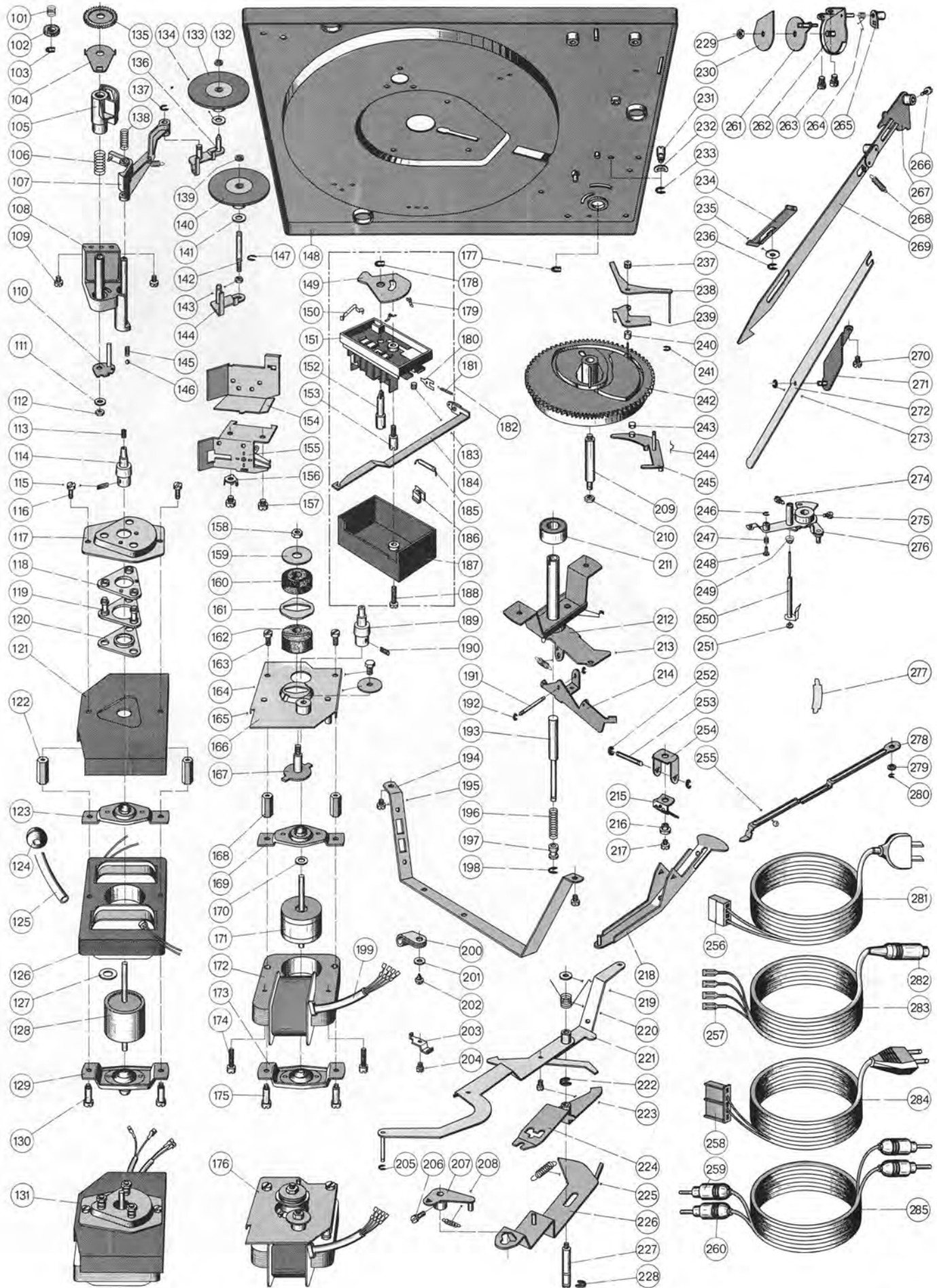



Fig. 27 Exploded view, parts below chassis



# Replacement parts

Ref. No.	Part. No.	Description	Quantity
1	215 470	Automatic spindle AS 12 (extra) .....	1
2	213 895	Changing spindle AW 3 .....	1
3	201 452	Facing ring 170 mm Ø .....	1
4	218 667	Turntable mat complete, with facing ring 170 mm Ø	1
	214 213	Turntable mat .....	1
5	218 666	Turntable complete, with turntable mat and facing ring 170 mm Ø .....	1
	214 212	Turntable complete, with mat .....	1
6	219 952	Speed change lever, left .....	1
7	219 965	Speed regulator knob complete .....	1
8	223 234	Blind (cm) .....	1
	223 235	Blind (inch) .....	1
9	223 233	Chassis complete .....	1
	230 181	Chassis complete (starting with Serial Number 186 459) .....	1
10	214 210	Shipping screw assembly complete .....	2
11	220 213	Centering disc for single discs .....	1
12	200 709	Single play spindle .....	1
13	214 054	Washer .....	1
14	200 543	Retaining ring .....	1
15	223 230	Tonearm complete .....	1
16	223 011	Tonearm rest assembly complete .....	1
17	210 362	Hex nut BM 3 .....	2
18	223 001	Tonearm head complete .....	1
19	201 132	Grip .....	1
20	210 182	Bowed lockwasher .....	1
21	210 630	Washer 4.2/8/0.5 St .....	1
22	210 197	"C" clip 4 x 0.8 .....	2
23	215 430	Cartridge mount TK 14 .....	1
24	219 954	Change lever right .....	2
25	219 954	Change lever right .....	2
26	210 816	Machine screw M 4 x 4 .....	1
27	216 936	Spacer (50 Hz) .....	1
28	210 184	Bowed lockwasher (50 Hz) .....	3
29	218 155	Machine screw M 4 x 6 (50 Hz) .....	1
	217 374	Centering screw (60 Hz) .....	1
30	210 366	Hex nut BM 4 .....	7
31	210 362	Hex nut BM 3 .....	2
32	209 353	Bearing race complete .....	2
33	200 579	Spring mounted footing (1 set = 3 pieces) .....	1
34	210 366	Hex nut BM 4 (4-pole-motor) .....	7
35	200 721	Bushing isolation mount .....	3
36	200 728	Compression spring .....	3
37	200 723	Rubber insert isolation mount .....	3
38	200 722	Steel cup .....	3
39	210 624	Washer 4.2/7/0.3 St .....	4
40	201 623	Rubber washer .....	2
41	200 713	Washer .....	2
42	200 712	Spring cup .....	2
43	200 711	Lockwasher .....	2
	210 366	Hex nut BM 4 .....	4
44	210 624	Washer 4.2/7/0.3 St .....	4
45	200 718	Compression spring .....	2
46	217 438	Threaded pin .....	1
47	200 829	Stop nut .....	1
48	218 636	Set screw .....	1
49	207 839	Damping ring .....	1
50	210 146	"C" ring 3.2 .....	3
51	223 005	Contact plate complete .....	1
52	222 125	Positioning screw .....	1
53	222 124	Holding device .....	1
54	222 122	Screw bolt .....	1
55	222 123	Cover .....	1
56	222 116	Bearing plate complete .....	1
57	211 364	Machine screw M 3 x 6 .....	1
58	217 894	Spring barrel complete .....	1
59	222 115	Tension spring .....	1
60	223 231	Tonearm bearing support .....	1
61	216 504	Indicator .....	1
62	217 436	Bearing screw complete .....	1
63	223 009	Dress-up plate complete .....	1
64	216 881	Lift lever complete .....	1
65	210 353	Hex nut BM 2 .....	1
66	217 905	Damping piece .....	1
67	213 260	Pin 2 x 6 .....	4
68	214 047	Special screw (pierced) .....	2
	214 211	Special screw (threaded) .....	2

Ref. No.	Part. No.	Description	Quantity
101	217 376	Compression spring .....	1
102	217 026	Cam wheel .....	1
103	210 197	"C" clip G 4 x 0.8 .....	2
104	217 233	Speed regulator detent .....	1
105	217 028	Switching segment .....	1
106	216 736	Compression spring .....	1
107	219 987	Switch lever complete (2-pole-motor) .....	1
	217 234	Switch lever complete (4-pole-motor) .....	1
108	216 558	Support complete .....	1
109	210 475	Machine screw AM 3 x 5 .....	9
110	217 239	Groove detent complete .....	1
111	210 642	Washer 4.2/10/1.5 St .....	1
112	210 361	Hex nut M 3 .....	2
113	217 751	Threaded pin M 2.6 x 8 .....	1
114	220 970	Motor pulley, 50 Hz, complete (4-pole-motor) ...	1
	220 971	Motor pulley, 60 Hz, complete (4-pole-motor) ...	1
115	210 220	Threaded pin M 2.6 x 3.5 .....	1
116	210 509	Machine screw AM 3.5 x 8 .....	2
117	204 669	Dress-up plate .....	1
118	221 386	Isolation mount plate .....	1
119	215 846	Mounting bracket complete .....	1
120	221 385	Isolation washer lower .....	1
121	204 665	Motor shield .....	1
122	200 167	Bearing spacer .....	2
123	204 686	Motor bearing top, complete .....	1
124	209 939	Sleeving .....	1
125	217 727	Isolation sleeve .....	1
126	217 591	Stator complete 110/220 V .....	1
127	220 807	Washer 4.5/9/1.2 F .....	1
128	204 687	Rotor complete .....	1
129	204 685	Motor bearing lower, complete .....	1
130	204 468	Screw bolt .....	2
131	220 973	Motor 110/220 V, complete .....	1
132	200 633	Lockwasher .....	1
133	217 888	Idler wheel complete .....	1
134	200 110	Washer .....	1
135	217 027	Speed regulator wheel .....	1
136	217 244	Idler arm complete (4-pole-motor) .....	1
137	210 146	"C" ring 3.2 .....	3
138	216 737	Compression spring .....	1
139	200 633	Lockwasher .....	1
140	217 888	Idler wheel complete .....	1
141	200 110	Washer .....	1
142	212 125	Idler wheel shaft (2-pole-motor) .....	1
143	210 361	Hex nut 8M 3 (2-pole-motor) .....	2
144	221 378	Idler arm complete with idler wheel shaft (2-pole-motor) .....	1
145	218 629	Compression spring .....	1
146	209 358	Steel ball 4 mm $\varnothing$ .....	2
147	210 145	"C" washer 2.3 (2-pole-motor) .....	10
148	223 233	Chassis complete .....	1
	230 181	Chassis complete (starting with Serial Number 186 459) .....	1
149	214 174	Contact support .....	1
150	214 176	Screen spring .....	1
151	217 060	Switch plate, complete, with voltage selector	1
	214 206	Switch plate, complete, less voltage selector	1
	223 006	Switch plate, complete, with voltage selector and SEMKO capacitor .....	1
152	214 173	Spindle .....	1
153	214 181	Screw bolt .....	1
154	201 240	Shield .....	1
155	207 447	Muting switch .....	1
156	211 614	Solder lug .....	1
157	210 475	Machine screw AM 3 x 5 .....	9
158	210 369	Hex nut M 5 .....	1
159	204 608	Washer .....	1
160	204 606	Rubber washer .....	1
161	204 607	Washer .....	1
162	222 186	Spacer .....	1
163	210 507	Machine screw AM 3.5 x 6 .....	2
164	210 472	Machine screw AM 3 x 4 .....	1
165	210 615	Washer 3.2/20/1.5 St .....	1
166	204 372	Shield complete .....	1
167	204 594	Holding disc .....	1

Ref. No.	Part. No.	Description	Quantity
168	204 476	Bearing spacer .....	2
169	204 686	Motor bearing top complete .....	1
170	220 807	Washer 4.5/9/1.2 F .....	1
171	220 461	Rotor complete .....	1
172	217 593	Stator 110/220 V complete .....	1
173	204 685	Motor bearing lower complete .....	1
174	210 522	Machine screw AM 4 x 18 .....	2
175	204 468	Screw bolt .....	2
176	223 232	2-pole-motor 110/220 V complete .....	1
177	210 149	"C" washer 6.0 .....	1
178	210 196	"C" clip G 3 x 0.6 .....	1
179	214 175	Contact spring .....	2
180	213 966	Snap spring .....	1
181	213 968	Tension spring .....	1
182	217 059	Power switch complete with voltage selector ...	1
	214 205	Power switch complete less voltage selector ...	1
	222 997	Power switch complete with voltage selector and SEMKO capacitor .....	1
183	218 986	Roller for switch slide .....	1
184	213 970	Switch slide complete .....	1
185	203 725	Suppressor capacitor .....	1
	221 186	SEMKO capacitor .....	1
186	213 978	Locking device, small .....	1
	213 979	Locking device, large .....	1
187	217 062	Cover for power switch with voltage selector	1
	214 207	Cover for power switch less voltage selector	1
	223 007	Cover for power switch with voltage selector and SEMKO capacitor .....	1
188	210 492	Machine screw AM 3 x 15 .....	1
189	212 135	Motor pulley 50 Hz complete (2-pole-motor) ....	1
	212 136	Motor pulley 60 Hz complete (2-pole-motor) ....	1
190	210 220	Threaded pin M 2.6 x 3.5 .....	1
191	217 813	Shaft .....	1
192	210 145	"C" washer 2.3 .....	10
193	213 918	Change actuator complete .....	1
194	220 165	Stand (2-pole-motor) .....	1
	217 617	Stand (4-pole-motor) .....	1
	221 309	Stand complete with RCA type jacks (2-pole-motor)	1
	217 759	Stand complete with RCA type jacks (4-pole-motor)	1
195	210 475	Machine screw AM 3 x 5 .....	9
196	213 920	Compression spring .....	1
197	213 921	Bushing .....	1
198	210 145	"C" washer 2.3 .....	10
199	210 731	Isolation sleeve .....	1
200	210 099	Plastic clamp for motor line .....	1
	220 152	Plastic clamp for power line .....	1
201	210 586	Washer 3.2/7/0.5 St .....	3
202	210 475	Machine screw AM 3 x 5 .....	9
203	200 447	Cable clamp .....	1
204	210 475	Machine screw AM 3 x 5 .....	9
205	210 145	"C" washer 2.3 .....	10
206	218 583	Machine screw M 3 x 4 .....	2
207	216 773	Switch-on lever .....	1
208	216 777	Tension spring .....	1
209	200 519	Bearing post for cam wheel .....	1
210	210 366	Hex nut BM 4 .....	7
211	200 554	Ball bearing .....	1
212	214 201	Bearing support complete .....	1
213	213 925	Tension spring .....	1
214	213 922	Cam rocker complete .....	1
215	201 186	Leaf spring .....	1
216	200 458	Spacer .....	1
217	210 480	Machine screw AM 3 x 6 .....	1
218	201 094	Main lever complete .....	1
219	210 586	Washer 3.2/7/0.5 St .....	3
220	213 940	Torsion spring .....	1
221	217 889	Switch arm complete .....	1
222	210 147	"C" washer 4 .....	3
223	210 475	Machine screw AM 3 x 5 .....	9
224	218 538	Switch lever complete .....	1
225	200 103	Tension spring .....	1
226	217 258	Start lever complete .....	1
227	217 334	Grooved shaft .....	1
228	210 147	"C" washer 4 .....	3

Ref. No.	Part. No.	Description	Quantity
229	210 366	Hex nut BM 4 .....	7
230	201 195	Cover washer .....	1
231	220 167	Set screw .....	1
232	210 187	Bowed lockwasher .....	1
233	210 147	"C" washer 4 .....	3
234	213 942	Latch complete .....	1
235	202 043	Washer 5.8/12/0.5 St .....	1
236	210 146	"C" washer 3.2 .....	4
237	220 235	Stop nut .....	1
238	220 232	Shut-off lever complete .....	1
239	222 690	Friction plate complete .....	1
240	221 935	Bushing .....	1
241	210 145	"C" washer 2.3 .....	10
242	220 332	Cam wheel complete .....	1
243	200 650	Sleeve .....	1
244	200 522	Snap spring .....	1
245	214 203	Cam follower lever complete with sleeve .....	1
246	210 143	"C" washer 1.5 .....	1
247	201 174	Compression spring .....	1
248	200 686	Spring pin .....	1
249	221 525	Conical spring .....	1
250	223 952	Lift rod complete .....	1
251	200 527	Shaft pin .....	1
252	210 145	"C" washer 2.3 .....	10
253	200 528	Shaft .....	1
254	201 185	Main lever bracket .....	1
255	209 358	Steel ball 4 mm $\phi$ .....	2
256	209 457	Inner casing for AMP plug .....	1
	209 458	AMP plug .....	3
257	209 436	Flat prong socket .....	4
258	213 980	Input jack housing .....	1
	213 982	AMP plugs .....	2
259	209 425	RCA type plug, yellow .....	2
260	209 426	RCA type plug, red .....	2
261	217 290	Drive washer complete .....	1
262	217 286	Support bracket complete .....	1
263	210 469	Machine screw AM 3 x 3 .....	3
264	217 296	Torsion spring .....	1
265	221 527	Drive cam .....	1
266	218 583	Machine screw M 3 x 4 .....	2
267	217 264	Record size selector lever complete .....	1
268	200 453	Tension spring .....	1
269	217 276	Arm positioning slide complete .....	1
270	210 511	Machine screw AM 4 x 4 .....	1
271	217 297	Main lever bracket complete .....	1
272	217 300	Connecting lever .....	1
273	210 145	"C" washer 2.3 .....	10
274	210 480	Machine screw AM 3 x 6 .....	2
275	210 482	Machine screw AM 3 x 6 (pierced) .....	1
276	214 209	Segment complete .....	1
277	200 687	Cranked spring lever .....	1
278	200 688	Shut-off slide .....	1
279	201 187	Friction desc .....	1
280	210 145	"C" washer 2.3 .....	10
281	213 984	Power cord complete with ground connection and U.S. type plugs .....	1
	207 311	Power cord complete with ground connection and AMP plug .....	1
282	209 424	Miniatur plug for audio cable .....	1
283	207 303	Audio cable complete with miniatur plug .....	1
284	220 142	Power cord complete .....	1
285	207 299	Audio cable complete with RCA type plugs .....	1
**	201 229	Cover pin .....	
**	214 120	Mounting hardware for cartridge .....	1
**	211 473	Stroboscope disc 50/60 Hz .....	1
**	214 219	Packing carton complete .....	1
**	222 686	Operating instructions, 4 languages .....	
**	222 330	Mounting instructions .....	

\*\* Not illustrated

Alterations reserved

Fig. 28 Power switch (66,5 x 38,5 x 30,5) starting with Serial Number 186 459

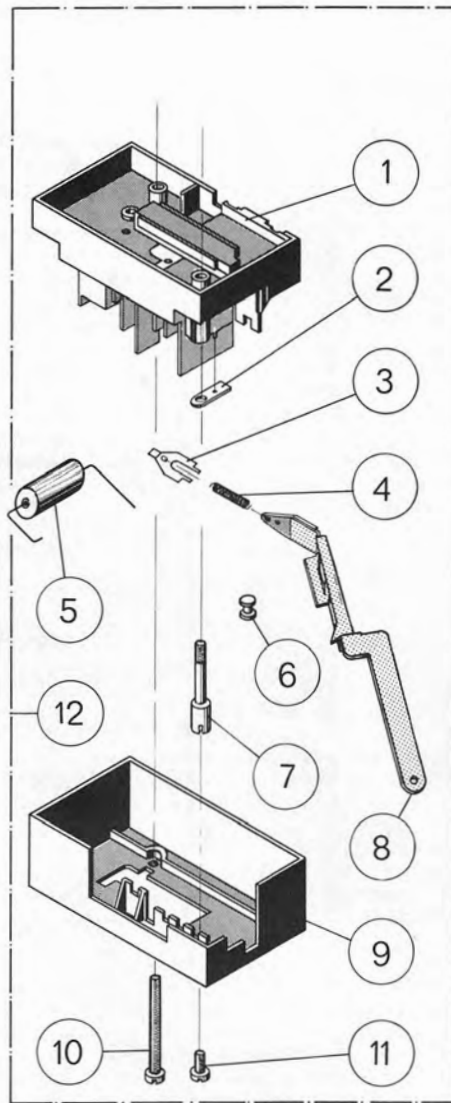

Replacement parts

Ref. No.	Part. No.	Description	Quantity
1	227 215	Switch plate with voltage selector, complete .....	1
	227 214	Switch plate without voltage selector, complete ..	1
	227 216	Switch plate with voltage selector, complete and SEMKO capacitor .....	1
2	223 617	Holding-down clamp .....	1
3	219 200	Toggle spring .....	1
4	227 209	Tension spring .....	1
5	223 603	Capacitor 10 nF/1000 V .....	1
	223 633	SEMKO-capacitor .....	1
6	223 621	Roller .....	1
7	224 183	Screw .....	1
8	223 618	Switch slide, complete .....	1
9	227 217	Cover for power switch with voltage selector .....	1
	227 218	Cover for power switch without voltage selector ..	1
10	210 501	Spezial screw AM 3 x 35 .....	1
11	210 480	Spezial screw AM 3 x 6 .....	1
12	227 222	Power switch complete with voltage selector .....	1
	227 220	Power switch complete without voltage selector (AMP) .....	1
	227 224	Power switch complete with voltage selector and SEMKO capacitor .....	1