

Dual

Service Manual

CS 1258

Download from www.dual.de
Not for commercial use



CONTENTS

- | | | | |
|---|-----------------------------|---|-----------------------------------|
| 2 | Service Figure | 6 | Record drop |
| 4 | Technical Data | | Muting switch |
| | Motor and Drive | | Shut-off and change cycle |
| | Pitch Control | | Shut-off mechanism |
| 5 | Tonearm and tonearm bearing | | Adjustments |
| | Antiskating device | | Ersatzteile / Replacement parts / |
| | Cue control | | Pièces détachée |
| | Tone arm control | 7 | Exploded view |
| | Start | | |
| | Manual start | | |
| | Stopping | | |

Dual Gebrüder Steidinger GmbH & Co. · 7742 St. Georgen/Schwarzwald

920 756-2 4/0881

Printed in Germany by Dual

Fig. 1 TA-Anschlußschema / Pick-up connection diagram / Schéma de branchement

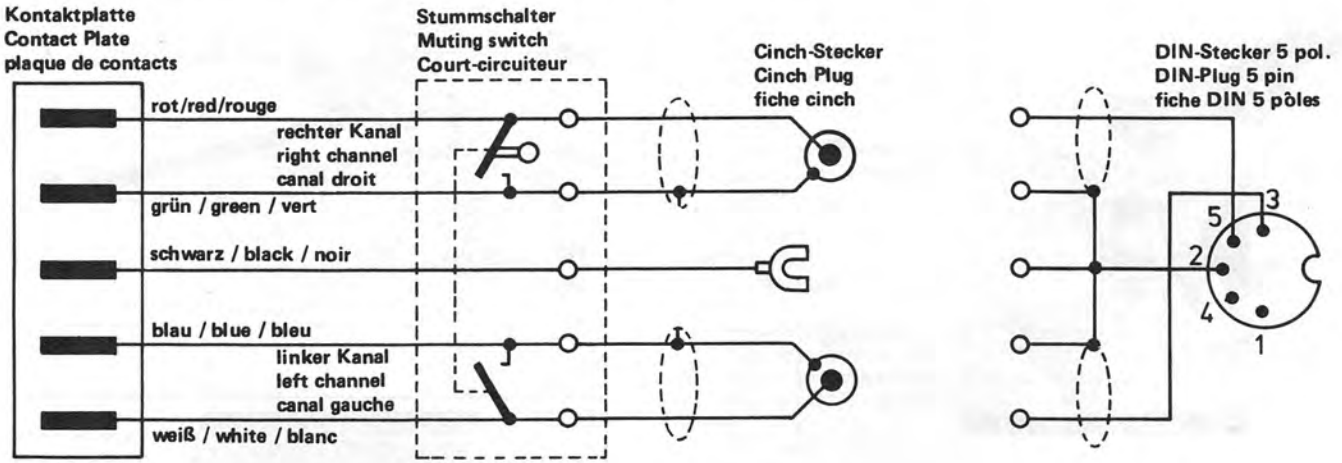

Fig. 2

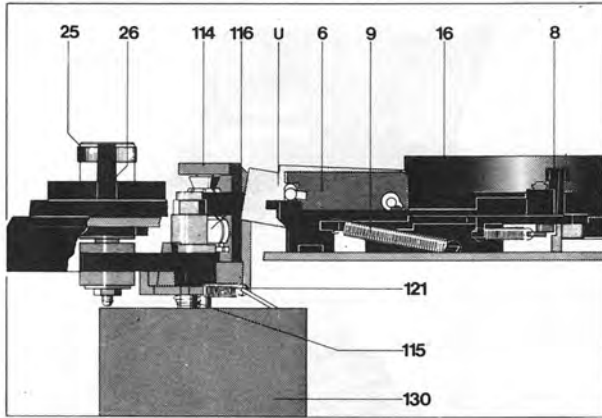

Fig. 3

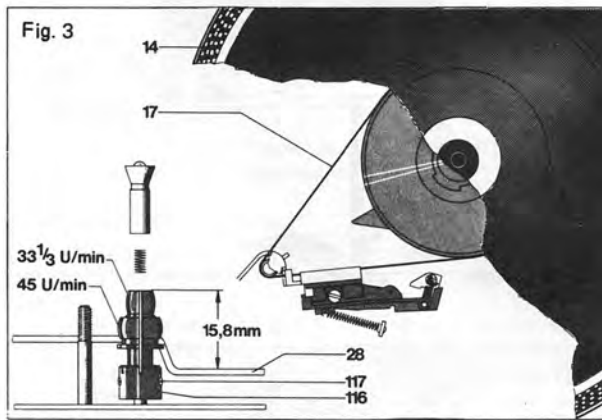

Fig. 4

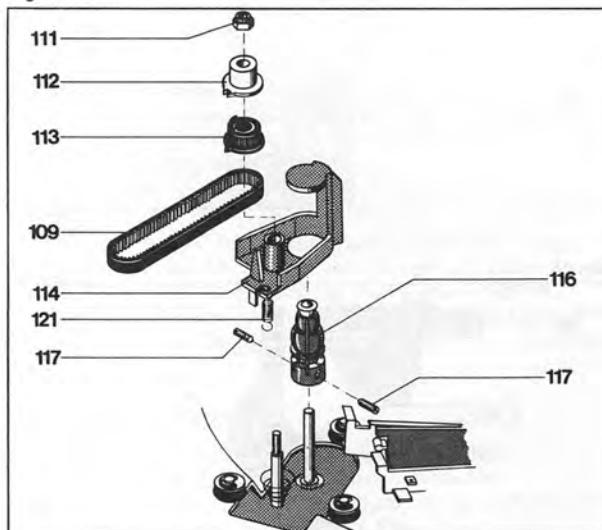

Fig. 5

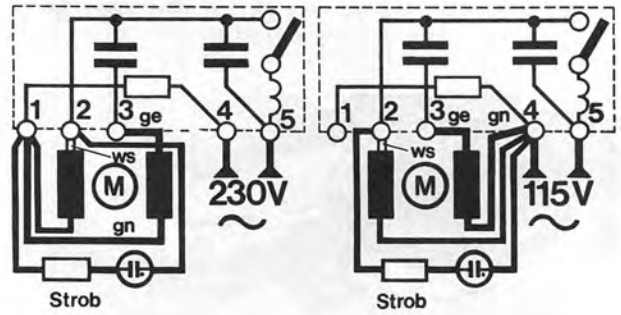

Fig. 6

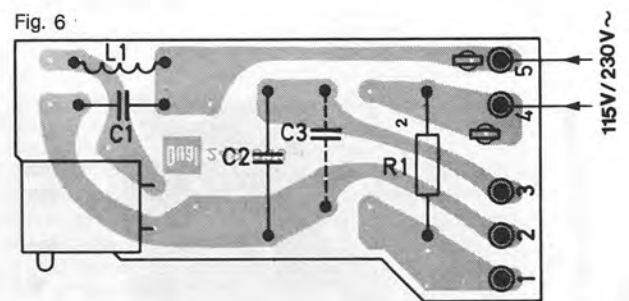

Fig. 7

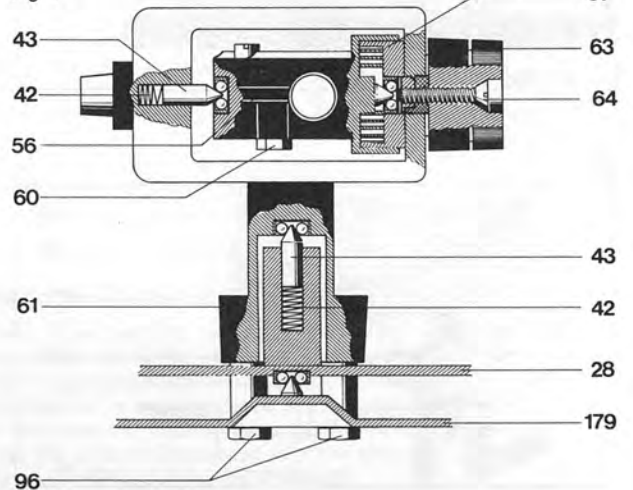

Fig. 8

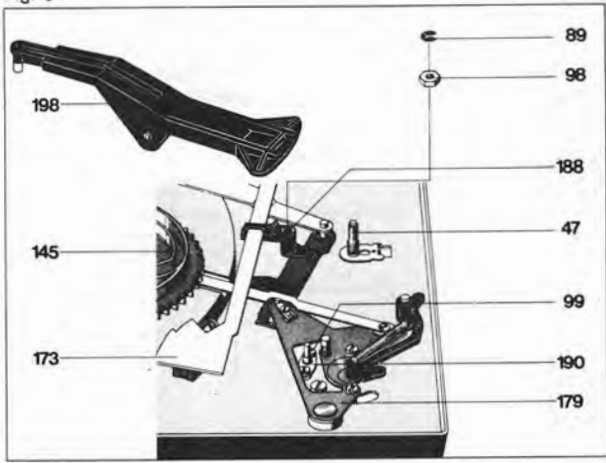

Fig. 9

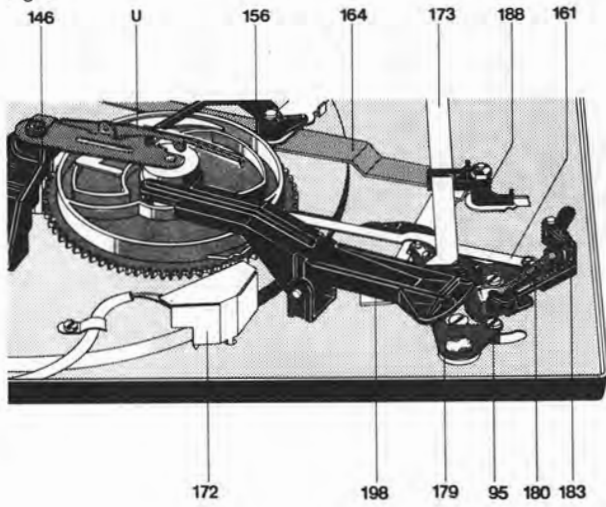

Fig. 10

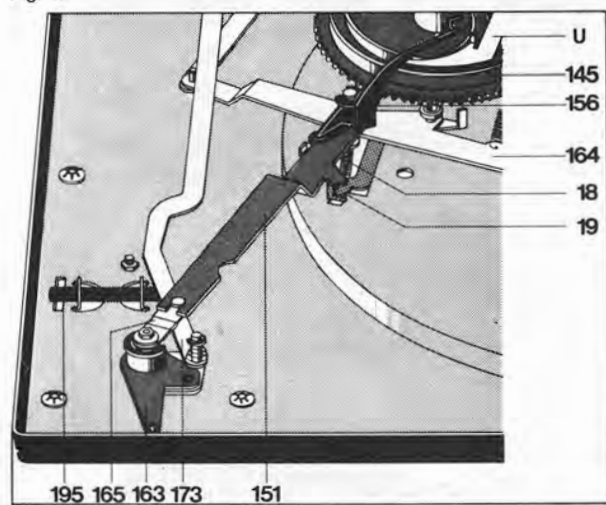

Fig. 11

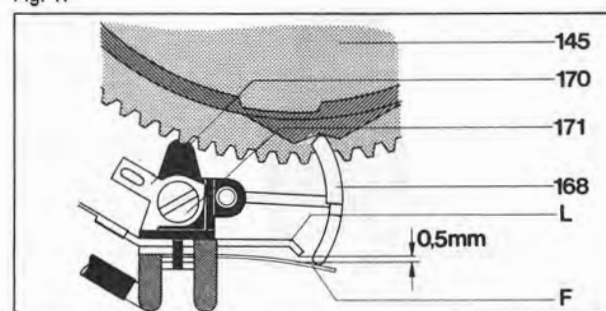

Fig. 12

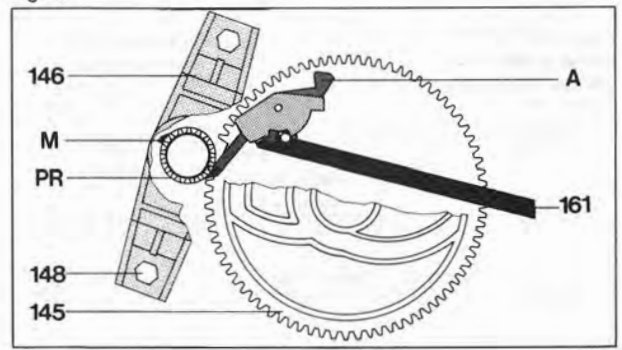

Fig. 13

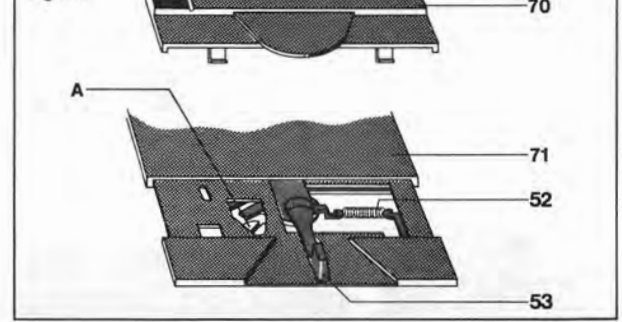

Fig. 14

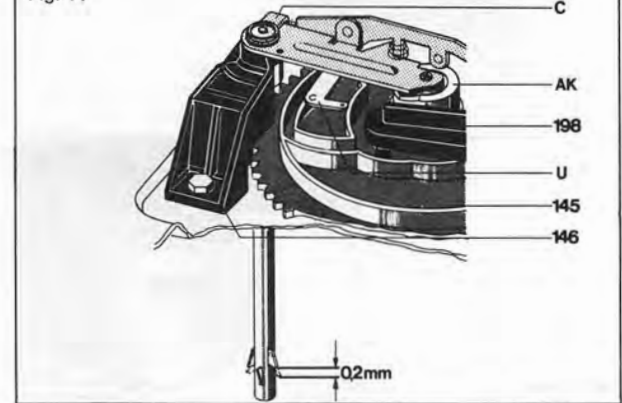

Fig. 15

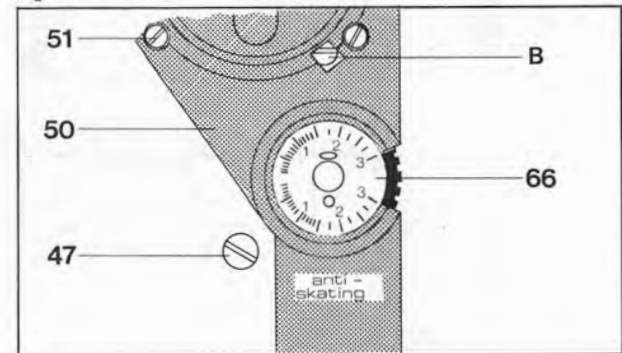
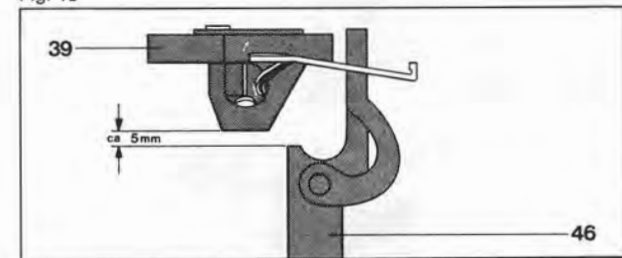

Fig. 16



Te
Cur
AC
the
Lin
11E
Plea
unc
Dri
Dua
Pow
Ma:
Plat
Alu
Plat
33
spe
Pitc
Adj
at b
Mo
Pow
sup
ada
cor
Pul
Loc
Cap
in c
Cor
cor
Spe
Plat
flat
(Fi
The
or
lev
ne
loc
rail
mo
pul
Pla
The
cat
ligh
unt
Fla
As
cha
fla
Wa
Re
pu
Ch
1.
2.
3.

Technical Data

Current type

AC 50 or 60 Hz convertible by changing the drive capstan and the motor.

Line voltage

115 and 230 V changeable

Please also note the voltage details of the type plate on the underside of the turntable.

Drive

Dual 16 pole synchronous motor via flat belt to flywheel rotor

Power consumption

Maximum 8 watt

Platter

Aluminium platter 270 mm ϕ , 1 kg

Platter speeds

33 1/3 and 45 rpm, automatic tonearm setdown coupled to speed selector

Pitch control

Adjustment at 33 1/3 rpm. Approximately 1 semi-tone (6 %) at both platter speeds.

Wow and flutter

$< \pm 0.08$ % rated in accordance with DIN 45 507

$< \pm 0.06$ % WRMS

Signal-to-noise-ratio (according to DIN 45 500)

Rumble unweighted signal-to-noise-ratio

> 44 dB

Rumble signal-to-noise-ratio

> 68 dB

Tonearm

distortion-free "ultra-low-mass", aluminum tubular tonearm in gimbal 4 point tip bearing

Recommended tracking force

infinitely variable from 0 to 30 mN (0 – 3 g), with 1 mN (0.1 g) calibration in the range from 2 to 15 mN (0.2 – 1.5 g) operable from 2.5 mN (0.25 g)

Cartridge

see separate data sheet

Cartridges with 1/2 inch screw-type attachment and a total weight of 4.5 – 10 g can be fitted with the special accessories (Part. No. 265 902) which can be obtained from your specialist dealer.

Motor and Drive

Power for the turntable platter and the changing mechanism is supplied by a split 16-pole synchronous motor **130**. The motor is adapted to 50 or 60 cycle (Hz) power line frequencies by the correct choice of the motor pulley **116** and the locking rail **8**.

Pulley 50 Hz, Part No. 261 938 / 60 Hz, Part No. 261 939

Locking rail 50 Hz Part No. 261 916 / 60 Hz Part No. 264 027

Capacitor (C 3) on switch plate **136** should either be soldered in or removed.

Conversion to the given line voltage should be carried out in accordance with the connection diagram (Fig. 5).

Speed changeover

Platter speeds of 33 1/3 and 45 rpm are adjusted by linking the flat belt **17** to the corresponding step of the motor pulley **116** (Fig. 3).

The speed switch lever is brought into the required position (33 or 45 rpm) by means of the regulating knob **26**, the switch lever **108** and the spring lever of the switch levers. If the machine is switched off, then the switch lever is interlocked by the locking rail **8**. The speed is only pre-selected in this way. The locking rail **8** is only released when the platter **14** turns. This then moves the flat belt **17** onto the required step of the motor pulley **116**.

Platter

The platter is secured to the securing disc **5** by the bayonet catch. When removing the platter **14** press the securing disc lightly downwards and turn it approximately 60° to the right until it is felt to click out of position.

Flat belt

As described above, the platter must be removed in order to change the flat belt **17**. Remove the old flat belt. Place the new flat belt onto the running surface of the flywheel rotor **16**. Warning: The polished (matt) side of the belt face outwards. Replace the platter and lay the flat belt back over the motor pulley **116**.

Changing the drive pulley

1. Remove the flat belt **17** and the toothed belt **109**.
2. Detach tension spring **121** from motor plate **122**.
3. Remove the hex nut **111**, the adjustment cam **112** the belt pulley **113** and the counter bearing **114**.

4. Loosen grub screws **117** and remove motor pulley **116**. Place the replacement motor pulley on the motor axle. Remove the taper bush. Take care with the interior spacing bush. Adjust the motor pulley vertically (see fig. 3) and tighten the grub screws **117** uniformly. Place the taper bush in the motor pulley **116**.
5. Counter bearing **114**, belt pulley 1 **113** and adjustment cam **112** should now be fitted and the hex nut **111** should now be tightened. Replace the tension spring **121** and the toothed belt **109**. Fit the flat belt **17** onto the motor pulley.
6. Set the belt pulley **113** to its central position by turning the adjustment knob **26**. (The lug of the belt pulley should be evident in the middle of the drive pulley). Set the rated speed by means of the hex nut **111**. The rated speed may be increased by turning the hex nut **111** in a clockwise direction. The rated speed may be decreased by turning the screw in an anti-clockwise direction.

Pitch control

The unit has a separately adjustable pitch control. The two standard speeds 33 1/3 rpm and 45 rpm can be varied by a maximum of 6 % (approximately 1 semitone).

By turning the fine speed adjustment knob **25** the belt pulley 2 **103** can be moved. This rotation is transferred by means of the toothed belt **109** to the belt pulley 1, thus moving the counter bearing **114** and the taper bush of the drive pulley **116** upwards or downwards. The taper bush of the drive pulley **116** is designed to vary the diameter of the drive pulley thus varying the nominal speed within the tolerance of ± 3 %.

Tonearm and tonearm bearing

The light, torsion-resistant all metal tonearm is suspended in a gimbal. Suspension is by means of 4 hardened and precision polished steel points which rest in precision ball bearings. Tonearm bearing friction is thus reduced to a minimum. Before adjusting the tracking force to suit the built-in pick-up cartridge the tonearm is balanced with the scale set to zero. Balancing is effected by turning the weight **55**.

The tracking force is effected by tensioning the coil spring attached to the spring housing **57**. The spring housing **57** has graduated markings for a range of adjustment from 0 to 30 mN (0 - 3 g) which permit accurate adjustment of the tracking force.

Dismantling the tonearm complete with the tonearm bearing

We recommend the following procedure:

1. Secure the unit in a repair stand and turn the rotary turn switch **63** to the zero position. Lock the tonearm **38** in rest position. Remove the weight **55**.
2. Turn the unit over. Remove the screening plate **172**. Unsolder the tonearm connections at the muting switch.
3. Remove the main lever **198**. After removing the locking washer **89** turn the adjusting screw **47** until the guide bearing **188** and arm positioning slide **173** are free. Swing the arm positioning rail **173** onto the flywheel rotor bearing assembly.
4. Disengage the tension spring **180**. Remove the locking washer **88**.
Remove the shut-off rail **161** from the segment **179**.
5. Remove both hex nuts **96**. Grip the tonearm **38**. Remove the segment **179**. Remove the tonearm. Reassembly involves the reverse procedure.

Changing the tonearm or the spring housing

1. Secure the unit in a repair stand. Turn the rotary turn switch **63** to zero position. Lock the tonearm **38**. Remove the weight **55**.
2. Turn the unit over. Remove the screening plate **172** and solder off the tonearm connections at the muting switch. Turn the unit the right way up.
3. Remove the screw **64**. Take off the rotary turn switch **63** and washer **62**.
4. Press the bearing **56** in the direction of the spring bearing point **43**, so that the tonearm **38** may be removed from the front of the bearing frame **61**. The spring housing **57** or the tonearm **38** can now be changed.
For reassembly follow the reverse procedure.

Antiskating device

Adjustment of the antiskating force is made by turning the cam disc **66**. The skating lever **183** is displaced from the tonearm fulcrum by an amount depending on the setting of this control. The antiskating force is transmitted to the tonearm **38** via the tension spring **180** and segment **179**.

Optimum adjustment is carried out at the works for styli with a tip radius of 15 μm (spherical), and 5/6 x 18/22 μm (elliptical). Any alteration can only be carried out with the aid of a Dual Skate-0-Meter and a test record and should only be done by an authorised servicing agent.

Cue control

Raising the grip rod **196** to position "▼" or "▼" moves the lift cam and the slide bar so that the tonearm is raised from the record (or lowered onto it). The cue control takes precedence over the automatic cueing device. If the unit is started with the arm lever in the "▼" position, then the tonearm is guided over the record by the cueing mechanism. Only when the grip rod **196** is brought to the position "▼" will the tonearm be lowered onto the record.

The vertical lift height can be adjusted by means of the adjustment screw **47** and should be 3 - 5 mm.

Changing the lift plate

When changing the lift plate **190**, we recommend the following procedure:

1. Secure the unit in a repair stand and lock the tonearm in rest position. Turn the unit over.
2. Remove the main lever **198**.
3. Remove the lock washer **89**. Turn the adjustment screw **47** until the hex nut **96** can be removed. Lift off the positioning rail **173** and the guide bearing **188** and pivot towards the cam wheel **145**.
4. Remove the two machine screws **99**. Remove the complete lift plate **190**.

Reassembly involves the reverse procedure.

Tonearm control

Automatic movement of the tonearm is initiated by the control cams on the inside of the cam wheel **145** on rotating through 360°.

The control elements for raising and lowering are the main lever **198** and the lift plate **190**, for horizontal movement the main lever **198** and the segment.

The automatic tonearm set-down mechanism is designed for 30 cm and 17 cm records and is coupled to the platter speed changeover. The set-down points of the tonearm are determined by the spring pin of the segment **179** contacting the positioning rail **173**. Limitation of the horizontal movement of the tonearm is produced by the pin of the segment contacting the positioning rail **173**. Only during set-down does the main lever **198** lift the slide bar and the stop attached to it which, as a result, moves into the swivel range of the stop pin fitted on the segment. After completion of set down (lowering of the tonearm onto the record) the positioning rail **173** is released again and returns to neutral position. As a result the stop moves out of the swivel range of the stop pin so that unimpeded horizontal movement of the tonearm is possible for playing.

Start

Switching the switch button **53** into the "start" position initiates the following sequence:

- a) The start lever rotates the switchover lever **164** which is pivoted about the notched stud. At the same time, the switch arm **151** is moved and the motor **130**, via the power switch, and the platter starts turning.
- b) Operating the switch lever **53** also releases the start slide **19** which is drawn towards the cam by means of the tension spring **18**. This causes the shut-off lever on the cam to engage with the drive pinion and the cam turns.
- c) This switch lever **164** is coupled to the switch angle **156** and this is brought into the range of the shift lever so that the next rotation of the cam forces this into its starting position.

Manual start

The pawl **156** which is connected to the switch arm **151** engages in the four-sided plate when the tonearm is moved manually and retains the switch arm in this position.

The switch arm **151** connects the mains supply to the motor **130** and the platter **16** rotates.

When the run-out groove of the record is reached, the tonearm is lifted and the motor is switched off automatically. If, however, the tonearm is lifted off the record before the run-out groove, and returned by hand to the tonearm rest, then the bolt on the segment **179** disengages the pawl **156** so that the switch arm is returned to its starting position. This switches off the mains supply.

Stopping

When the switch lever is set to "stop" position the start angle **19** which is pulled towards the cam by means of the tension spring **18** is disengaged thereby moving the shut-off lever into contact with the platter pinion (PR) and moving the cam wheel **145**. The cam follower lever remains in its stop position.

Record drop

According to centre hole diameter (7 or 38 mm) either interchangeable spindle AW 3 or automatic spindle AS 12 are intended for stacking and dropping records.

The record drop is initiated by the cam wheel **145** whose drop cam surface (AK) controls the release rocker (AW) and the changer actuator rod. (Fig. 14).

The resultant downward movement initiates record drop via the changing spindle or automatic spindles.

Muting switch

To prevent disturbing noises during automatic operation of the tonearm the unit is fitted with a muting switch. Control of the switch springs for both channels is effected by the cam wheel. With the unit in neutral state, the muting of the pick-up leads is eliminated (Fig. 11).

Adjustment

In zero position of the cam there should be a clearance of approximately 0.5 mm between the contact springs (F) and the shorting strips (L). If necessary the shorting strips should be bent. The contacts should be sprayed with a suitable cleaning agent.

Shut-off and change cycle

The dog (M) on the turntable platter gear (PR) and the shut-off lever (A) actuate both the change cycle at the end of the record as well as the shut-off after the last record in a stack is played. At the end of a record, the tonearm moves towards the centre at an accelerated rate due to the increased pitch of the grooves. This motion carries the shut-off lever (A) towards the dog by means of the shut-off rail 161. The eccentric dog pushes the shut-off lever (A) back at each revolution as long as the tonearm advance is only one normal record groove (Fig. 12). The run-out groove with its steeper pitch moves the shut-off lever (A) against the dog with greater force, engaging the shut-off lever (A) and causing the main cam wheel 145 to be driven out of its neutral position by the turntable platter gear.

Shut-off mechanism

Shut-off and change functions are determined by the position of the cam follower lever (U). After every start or record drop, the cam follower lever is brought to its stop position by the main lever 198. (Longer end towards the centre of the main cam). As the record is dropped the cam follower lever (U) is turned to its start position by the cam rocker, so that the tonearm can swing in towards the record and be lowered onto it. If there are no more records on the spindle, the cam rocker remains locked in its lower position and cannot turn the cam follower lever so that the lever remains in its stop position and allows the tonearm to swing to its rest position. When the main cam wheel 145 returns to its neutral position, the roller 150 of the switch arm 151 drops into a cutout in the main cam, opening the power switch.

Defect

After operating the lever the tonearm does not set down or sets down too fast.

Cause

Damping is too great or too slight due to dirt in the silicon oil of the lift tube

Rated speed is at the limit of pitch adjustment.

inexact positioning of the belt pulley.

Adjustment

Tonearm set-down point

After removing the notched plate 70 (by pressing it forward and lifting the rear edge first) the adjustment screw (A) is accessible. The stylus set-down point can be varied towards the centre or the outside by turning the adjustment screw to the right or left respectively (Fig. 13).

Switch off position

With the tonearm on the tonearm rest, the eccentric (B) can be adjusted to alter the switch-off position (shut-off range record ϕ 116 to 122 mm). The eccentric is accessible through the hole in the supporting back plate. If the unit switches off too early or not at all, then the eccentric (B) should be turned to the right or left respectively (Fig. 14).

Release rocker

The lift of the change actuator rod may be changed by bending the release rocker. The change actuator rod is correctly adjusted if, with the cam 145 in zero position, and the change spindle locked in position, the three supports of the change spindle permit a longitudinal movement of 0.2 mm when the change actuator rod is pressed upwards (Fig. 15).

Tonearm vertical lift

The adjusting sleeve 192 is used to adjust the tonearm vertical lift (for automatic operation). Pull out the mains plug, unlock the tonearm, turn the cam wheel 145 from its zero position until the tonearm reaches its highest point of travel. The tonearm should now be approximately 5 mm above the tonearm rest stop (see Fig. 16). Adjust by means of sleeve 192.

Repair

Remove the lift plate assembly 190. Remove the control stud 191. Remove the lock washer 87. Unscrew the adjusting sleeve 192. Remove the locking washer 87. Remove the lifting bolt and the pressure spring. Clean the lift tube and lifting bolt. Coat the lifting bolt at the same time with 'Wacker Siliconöl AK 100 000'. Reassemble the parts.

By rotating the regulating button 25 bring the belt pulley 112 into its central position. (The lug of the belt pulley should be visible in the centre of the drive pulley). Adjust the rated speed with the hex nut 111. Turning the hex nut 111 clockwise increases the rated speed. Turning the hexagonal screw anti-clockwise reduces the rated speed.

Ersatzteile · Replacement parts · Pièces détachées

Pos.	Art.-Nr. Part.-No. Réf.	Stck. Qty. ndp.	Bezeichnung	Description	Désignation
1	215 470	1	Abwurfsäule	Automatic Spindle	Axe changeur
2	213 895	1	Wechselachse	Change spindle	Axe changeur
3	220 213	1	Zentrierstück	Centering piece	Centreur
4	261 910	1	Mitlaufstift	Idling pin	Axe de plateau
5	261 912	1	Befestigungsscheibe	Securing disc	Rondelle de fixation
6	261 914	1	Träger kpl.	Support cpl.	Support compl.
7	248 346	1	Druckfeder	Compression spring	Ressort de pression
8	261 916	1	Sperrschiene 50 Hz	Locking rail 50 Hz	Barre d'arrêt 50 Hz
	264 027	1	Sperrschiene 60 Hz	Locking rail 60 Hz	Barre d'arrêt 60 Hz
9	249 171	1	Zugfeder	Tension spring	Ressort de traction
10	248 347	1	Zugfeder	Tension spring	Ressort de traction
11	248 886	1	Anschlag	Stop	Butée
12	270 387	1	Plattentellerbelag	Platter mat	Tapis du plateau
13	248 893	1	Federscheibe	Spring washer	Rondelle elastique

Exploded view 1

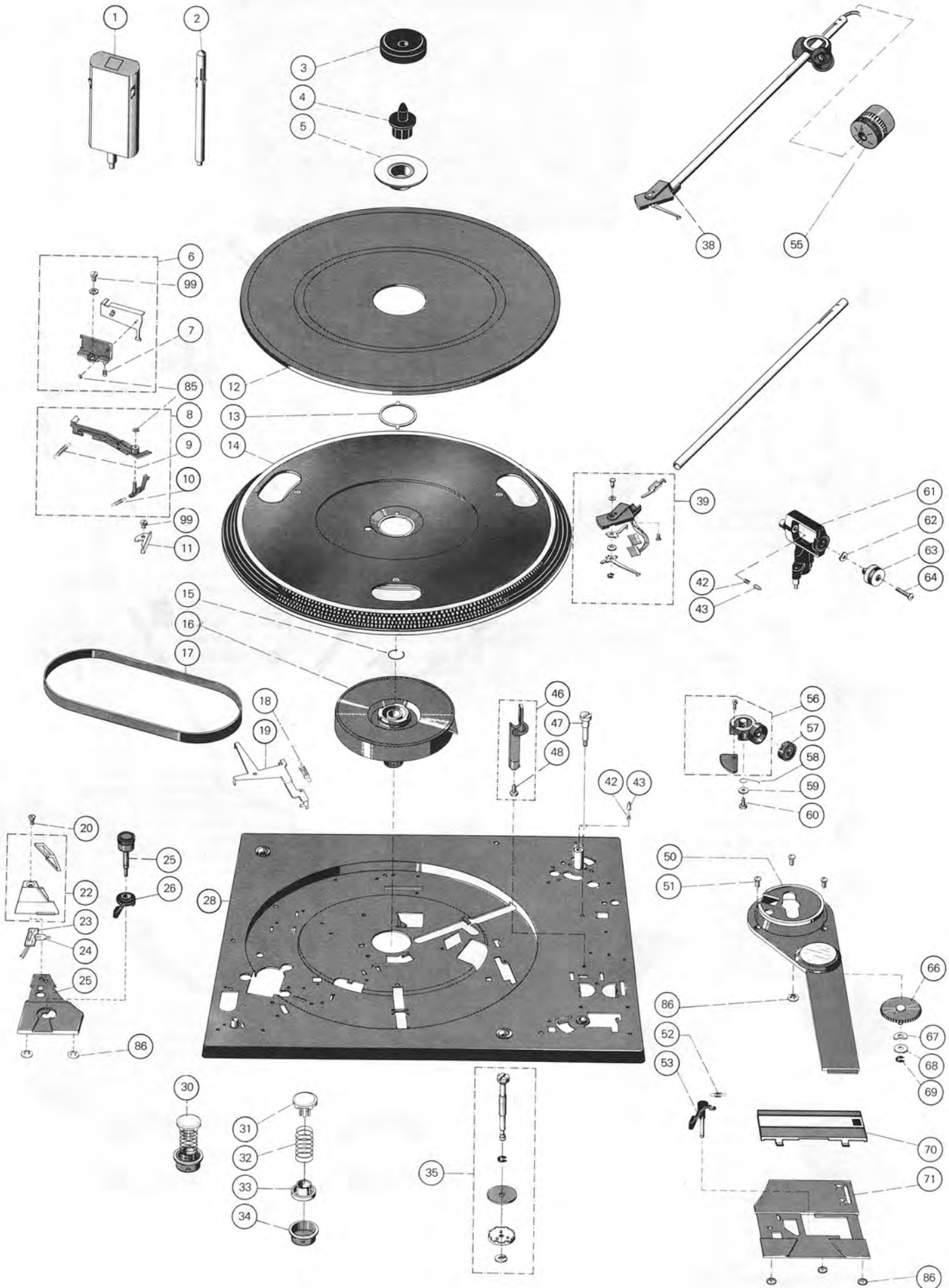

Exploded view 2

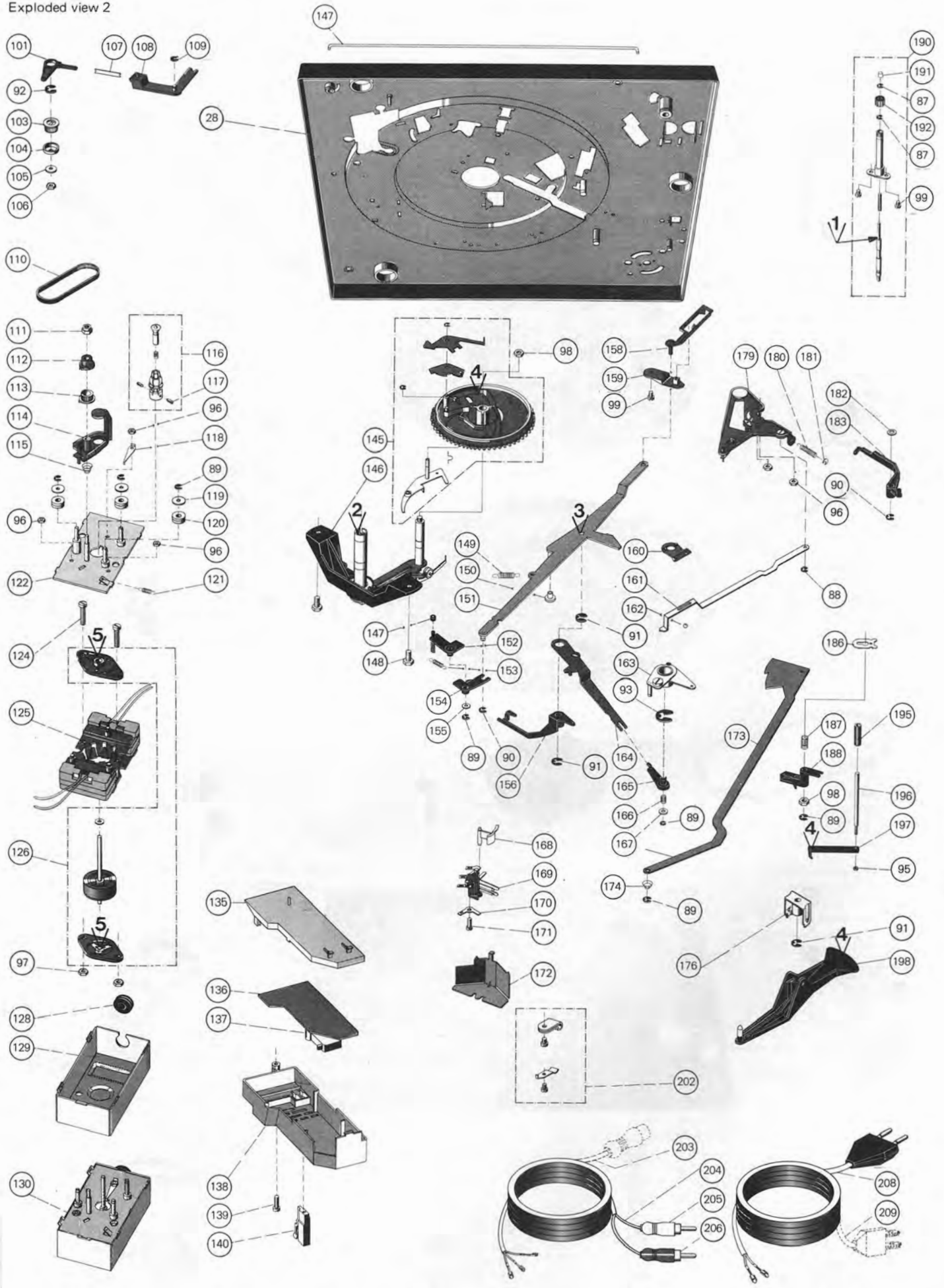

- 1** Wacker Siliconöl
AK 300 000
- 2** Haftöl Renotac
Nr. 343
- 3** BP Super Viscostatik
10 W/40
- 4** Shell Alvania Nr. 2
- 5** Isoflex PDP 40

Pos.	Art.-Nr. Part-No. Référ.	Stck. Qty. ndp.	Bezeichnung	Description	Désignation	
14	270 389	1	Plattenteller kpl.	Platter with mat	Plateau compl.	
15	200 543	1	Sprengring	Snap ring	Anneau de retenue	
16	261 920	1	Antriebsteller kpl.	Fly wheel rotor cpl.	Disque moteur compl.	
17	261 921	1	Flachriemen	Flat belt	Courroie plate	
18	231 017	1	Zugfeder	Bearing	Support	
19	239 926	1	Startwinkel	Start angle	Equerré de Start	
20	268 535	1	Linsensenkschraube	M 3 x 6	Vis à tête fraisée bombée	M 3 x 6
22	268 489	1	Stroboskopgehäuse kpl.	Stroboscope housing	Boîtier de stroboscope	
23	249 092	1	Printplatte	Print board	Plaque de print	
24	260 421	1	Glimmlampe	Glimm lamp	Lampe à effluves	
25	268 569	1	Drehzahlabdeckung	Pitch control covering	Couvercle des vitesses	
26	268 571	1	Regulierknopf	Regulating knob	Bouton de réglage	
27	268 570	1	Drehzahlhebel	Speed lever	Levier des vitesses	
28	270 390	1	Einbauplatte	Mounting plate	Plaque encastrée	
30	234 815	3	Federaufhängung kpl.	Spring suspension	Suspension	
31	230 529	3	Gewindestück	Threaded piece	Pièce filetée	
32	234 109	3	Druckfeder	Pressure spring	Ressort de pression	
33	200 723	3	Dämpfungsgummi	Dumping rubber	Amortisseur en caoutchouc	
34	200 722	3	Topf	Casing	Pot	
35	214 210	1	Transportsicherung	Transport lock	Système de protection pour le transport	
38	270 393	1	Tonarm kpl.	Tonearm cpl.	Bras de lecture compl.	
39	270 394	1	Tonarmkopf kpl.	Tonearm head cpl.	Tête de lecture compl.	
41	265 902	1	Umrüstsatz 1/2 Zoll kpl.	1/2 inch conversion kit cpl.	Jeu de transformation 1/2 pouce compl.	
42	229 685	2	Druckfeder	Pressure spring	Ressort de pression	
43	229 655	2	Lagerspitze	Bearing point	Pointe de support	
46	270 395	1	Stütze kpl.	Tonearm rest cpl.	Support compl.	
47	239 809	1	Stellschraube	Adjusting screw	Vis de réglage	
50	270 396	1	Abdeckung hinten kpl.	Rear covering cpl.	Revêtement arrière compl.	
51	268 535	3	Linsensenkschraube	M 3 x 6	Vis à tête fraisée bombée	M 3 x 6
52	226 357	1	Zugfeder	Tension spring	Ressort de traction	
53	268 177	1	Schalttaste	Switch button	Touche de commande	
55	270 397	1	Gewicht kpl.	Counter weight cpl.	Contre-poids compl.	
56	268 551	1	Lager kpl.	Bearing cpl.	Palier complete	
57	261 934	1	Federhaus kpl.	Spring housing cpl.	Cage de ressort compl.	
58	265 878	1	Haltefeder	Wire spring	Ressort à boudin	
59	210 597	1	Scheibe	Washer	Rondelle	
60	242 806	1	Sechskantblechschraube	BZ 2,9 x 6	Vis	BZ 3,9 x 6
61	268 554	1	Lagerrahmen kpl.	Bearing race cpl.	Cadre de support compl.	
62	261 798	1	Scheibe gew.	Washer	Rondelle	
63	276 484	1	Drehknopf	Rotary turn switch	Bouton rotatif	
64	249 097	1	Linsenschraube	M 2,5 x 12	Vis à tête fraisée bombée	M 2,5 x 12
66	268 546	1	Kurvenscheibe kpl.	Cam disc	Rondelle	
67	242 298	1	Scheibe gew.	Washer	Rondelle	
68	228 113	1	Scheibe	4,2/8/1	Washer	4,2/8/1
69	210 146	1	Sicherungsscheibe 3,2	Lock washer 3,2	Anneau de retenue 3,2	
70	268 482	1	Rastplatte	Notched plate	Plaque d'arrêt	
71	268 545	1	Abdeckung vorne kpl.	Front covering	Revêtement avant	
72	200 444	5	Federscheibe	Spring washer	Rondelle élastique	
86	200 444	10	Federscheibe	Spring washer	Rondelle élastique	
87	210 143	3	Sicherungsscheibe 1,5	Lock washer 1,5	Anneau de retenue 1,5	
88	210 144	1	Sicherungsscheibe 1,9	Lock washer 1,9	Anneau de retenue 1,9	
89	210 145	9	Sicherungsscheibe 2,3	Lock washer 2,3	Anneau de retenue 2,3	
90	210 146	3	Sicherungsscheibe 3,2	Lock washer 3,2	Anneau de retenue 3,2	
91	210 147	3	Sicherungsscheibe 4	Lock washer 4	Anneau de retenue 4	
92	210 149	1	Sicherungsscheibe 6	Lock washer 6	Anneau de retenue 6	
93	232 621	1	Sicherungsscheibe 8	Lock washer 8	Anneau de retenue 8	
96	210 362	4	Sechskantmutter	M 3	Ecrou à six pans	M 3
98	210 366	5	Sechskantmutter	M 4	Ecrou à six pans	M 4
99	210 472	5	Zylinderschraube	M 3 x 4	Vis à tête cylindrique	M 3 x 4
101	248 877	1	Umschaltwinkel	Switchover bracket	Equerre de commutation	
102	210 149	1	Sicherungsscheibe	Lock washer	Anneau de retenue	
103	232 097	1	Riemenrad 2	Belt pulley 2	Poulie 2	
104	240 035	1	Scheibe	Washer	Rondelle	
105	210 607	1	Scheibe	Washer	Rondelle	
106	210 362	1	Sechskantmutter	M 3	Ecrou à six pans	M 3
107	248 889	1	Blattfeder	Leaf spring	Ressort à lames	
108	248 874	1	Schalthebel	Switch lever	Levier de commande	
109	210 194	1	Greifring	G 2 x 0,6	Circlip	G 2 x 0,6
110	238 832	1	Zahnriemen	Toothed belt	Courroie dentée	
111	244 104	1	Sechskantmutter	M 3,5	Ecrou à six pans	M 3,5
112	241 641	1	Einstellkurve	Adjustment cam	Carne de réglage	
113	241 642	1	Riemenrad 1	Belt pulley 1	Poulie 1	
114	248 508	1	Gegenlager	Counter bearing	Palier de butée	
115	232 615	1	Druckfeder	Pressure spring	Ressort de pression	
116	261 938	1	Antriebsrolle 50 Hz kpl.	Drive capstan 50 Hz cpl.	Rouleau de commande 50 Hz compl.	
116	261 939	1	Antriebsrolle 60 Hz kpl.	Drive capstan 60 Hz cpl.	Rouleau de commande 60 Hz compl.	
117	233 137	2	Gewindestift	M 2,5 x 3	Tige filetée	M 2,5 x 3
118	247 920	1	Massebügel	Earth bracket	Etrier de masse	
119	210 600	3	Scheibe	Washer	Rondelle	
120	249 137	3	Dämpfungstülle	Damping sleeve	Douille d'amortissement	

Pos.	Art-Nr. Part-No. Réf.	Stck. Qty. ndp.	Bezeichnung	Description	Désignation
121	233 777	1	Zugfeder	Tension spring	Ressort de traction
122	248 507	1	Motorplatte kpl.	Motor plate cpl.	Plaque de moteur compl.
123	248 335	2	Zylinderschraube M 3,5 x 20	Machine screw	Vis à tête cylindrique M 3,5 x 20
125	261 944	1	Stator 110/220 V	Stator 110/220 V	Stator 110/220 V
	261 946	1	Stator 110/220 V UL/CSA	Stator 110/220 V UL/CSA	Stator 110/220 V UL/CSA
126	261 945	1	Anker mit Lager	Armature with bearing	Induit avec palier
127	222 200	2	Sechskantmutter M 3,5	Hex nut	Ecrou à six pans M 3,5
128	209 939	1	Durchführungsstülle	Wire protective sleeve	Douille
129	247 858	1	Abschirmblech	Screening plate	Tôle de blindage
130	261 950	1	Motor 110/220 V kpl.	Motor 110/220 V cpl.	Moteur 110/220 V
135	248 880	1	Gehäuse	Housing	Boîtier
136	261 964	1	Schalterplatte SM 100 (50 Hz) kpl.	Switch plate SM 100 (50 Hz) cpl.	Plaque de manoeuvre SM 100 (50 Hz)
	261 965	1	Schalterplatte SM 100 kpl.	Switch plate SM 100 cpl.	Plaque de manoeuvre SM 100 (60 Hz)
137	249 350	1	Mikroschalter	Switch	Interrupteur
138	248 881	1	Deckel	Cover	Couvercle
C	1	241 646	10 nF/250 V/20 %	10 nF/250 V/20 %	10 nF/250 V/20 %
C	2	249 352	0,33 µF/250 V/10 %	0,33 µF/250 V/10 %	0,33 µF/250 V/10 %
C	3	230 355	68 nF/250 V/20 %	68 nF/250 V/20 %	68 nF/250 V/20 %
L	1	242 822	47 mH	47 mH	47 mH
R	1	249 354	5,1 kΩ/5 W/5 %	5,1 kΩ/5 W/5 %	5,1 kΩ/5 W/5 %
144	239 925	1	Schaltstange	Switch rod	Tige de commande
145	261 966	1	Kurvenrad kpl.	Cam wheel cpl.	Roue à cammes compl.
146	261 968	1	Lagerbrücke kpl.	Fly wheel rotor bearing cpl.	Pont de support compl.
147	200 650	2	Gummitülle	Rubber sleeve	Douille en caoutchouc
148	218 155	2	Sechskantschraube M 4 x 6	Hex screw	Vis hexagonale M 4 x 6
149	249 076	1	Zugfeder	Tension spring	Ressort de traction
150	239 931	1	Rolle	Roller	Rouleau
151	248 891	1	Schaltarm	Switch arm	Bras de commande
152	248 878	1	Schalterhebel	Switch lever	Levier de commande
153	260 363	1	Zugfeder	Tension spring	Ressort de traction
154	248 879	1	Betätigungshebel	Actuation lever	Levier de commande
155	210 586	1	Scheibe 3,2/7/0,5	Washer	Rondelle 3,2/7/0,5
156	230 933	1	Umschaltwinkel	Switchover bracket	Equerre de commutation
158	248 868	1	Klinke	Pawl	Cliquet
159	239 915	1	Vierkantplatte	Square plate	Plaque de carrée
160	248 869	1	Kugelbett	Ball base	Plateau à bille
161	248 873	1	Abstellschiene	Shut-off-rail	Barre d'arrêt
162	209 357	1	Kugel φ 3,2	Ball φ 3,2	Bille φ 3,2
163	248 995	1	Einstellhebel kpl.	Adjusting lever cpl.	Levier de réglage compl.
164	249 077	1	Umschalthebel	Switchover lever	Levier de commutation
165	248 871	1	Einschalthebel	Switch-on lever	Levier de connexion
166	248 872	1	Druckfeder	Pressure spring	Ressort de pression
176	210 619	1	Scheibe 3,7/8,1/1	Washer 3,7/8,1/1	Rondelle 3,7/8,1/1
168	239 807	1	Kontaktarm	Contact arm	Bras de contact
169	242 612	1	Kurzschließer	Muting switch	Court-circuiteur
170	239 806	1	Masseblech	Earth plate	Tôle de masse
171	210 486	1	Zylinderschraube M 3 x 8	Machine screw	Vis à tête cylindrique M 3 x 8
172	239 808	1	Abschirmblech	Screening plate	Tôle de blindage
173	266 654	1	Stellschiene	Positioning rail	Barre de réglage
174	243 706	1	Kegelfeder	Conical spring	Ressort conique
176	239 947	1	Lagerbock	Bearing block	Support
179	261 969	1	Segment	Segment	Segment
180	218 591	1	Zugfeder	Tension spring	Ressort de traction
181	201 184	1	Einstellscheibe	Adjusting washer	Rondelle de réglage
182	242 298	1	Scheibe	Washer	Rondelle
183	239 917	1	Skatinghebel	Skating lever	Levier de skating
186	239 810	1	Sicherungsfeder	Lock washer	Ressort d'arrêt
187	235 150	1	Druckfeder	Pressure spring	Ressort de pression
188	239 934	1	Führungslager	Guide bearing	Palier de guidage
190	242 613	1	Liftplatte kpl.	Lift plate	Plaque de leve-bras
191	216 844	1	Steuerpimpel	Control stud	Tige de commande
192	218 318	1	Stellhülse	Adjusting sleeve	Douille de réglage
195	237 543	1	Gummitülle	Rubber sleeve	Douille en caoutchouc
196	247 440	1	Griffstange	Grip rod	Tige à poignée
197	239 909	1	Hubkurve	Lift cam	Came de levée
198	242 616	1	Haupthebel	Main lever	Levier principal
202	231 079	1	Kabelschellen	Cable clamp	Collier pour câbles
203	207 303	1	Tonabnehmerkabel 5-polig kpl.	Cartridge lead	Câble de cellule
204	207 301	1	Tonabnehmerkabel Cinch kpl.	Cynch cartridge lead	Câble de cellule Cynch
205	209 425	1	Cinch-Stecker weiß	White cynch plug	Fiche Cynch blanche
206	209 426	1	Cinch-Stecker schwarz	Black cynch plug	Fiche Cynch noire
208	232 996	1	Netzkabel Europa	European mains lead	Câble secteur européen
209	232 995	1	Netzkabel USA	USA mains lead	Câble secteur Etats-Unis
	270 246	1	Abdeckhaube CH 17	Cover CH 17	Capot CH 17
	270 248	1	Konsole CK 32 A	Console CK 32 A	Console CK 32 A
	246 079	1	Befestigungsplatte kpl.	Securing plate	Plaque de fixation
	268 524	1	Verpackung kpl.	Shipping carton	Carton d'emballage
	268 521	1	Bedienungsanleitung	Operating instructions	Instructions de service

Änderungen vorbehalten!

Alteration reserved!

Sous réserve de modifications!