

Download from www.dual.de
Not for commercial use

Dual

October 1976 Edition

502



Service - Manual

Dual Gebrüder Steidinger · 7742 St. Georgen/Schwarzwald

Fig. 1 Pick-up connection diagram

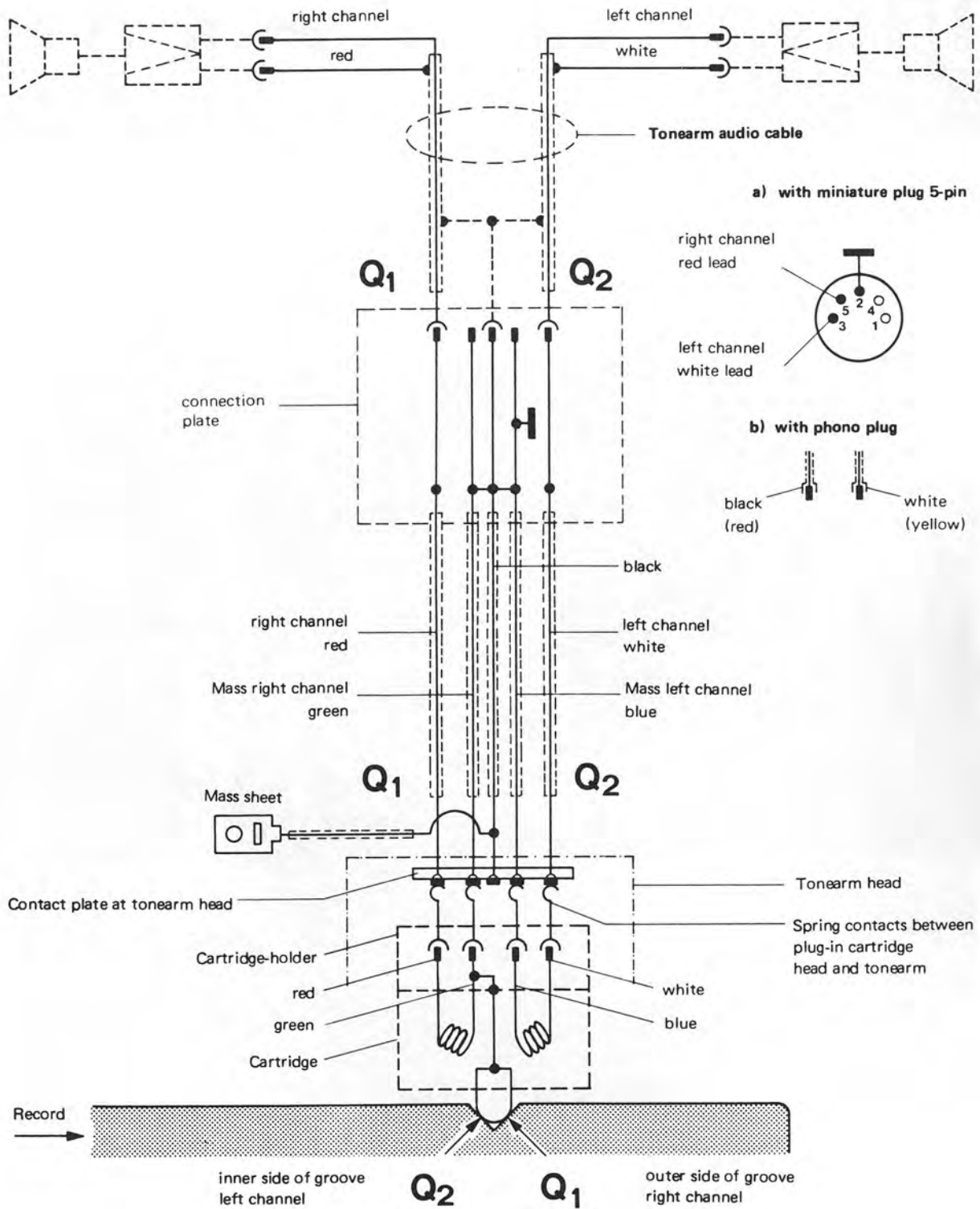

Contents

	Page
Pick-up Connection Diagram	2
Specification	3
Motor and Drive	4
Replacement of motor pulley	4
Setting nominal speed	4
Tonearm and Tonearm Suspension	5
Removal of tonearm from bearing frame	5
Removal of tonearm assembly with tonearm bearing	5
Replacement of spring housing	5
Adjusting the tonearm bearing	6
Anti-Skating device	6
Cue Control	6
Replacement of cue control assembly	7
Starting and Shut-off	7
Tonearm not parallel to platter	8
Platter does not start after connecting the unit to power line and moving the tonearm inwards	8
Platter does not reach nominal speed	8
Stylus slips out of playing groove	8
Tonearm does not lower or lowers onto record too quickly when cue control is operated	8
Acoustic feedback	8
Exploded views	10, 11
Spare parts	9, 11, 13
Lubrication	14

Specification

Current type	AC 50 or 60 Hz, selected by exchanging drive pulley
Line voltages	110 – 130 volts and 220 – 240 volts
Motor and Drive	Dual 8-pole synchronous motor with flat belt drive system
Power Consumption	< 10 watts
Current Consumption	with 220 V 50 Hz, about 75 mA, with 110 V 60 Hz about 140 mA
Platter	Non-magnetic, 1.3 kg, 300 mm dia.
Platter speeds	33 1/3 and 45 rpm
Overall speed variation	< ± 0.09 % (assessed in accordance with DIN 45 507)
Signal-to-noise ratio	Rumble weighted signal-to-noise ratio > 62 dB Rumble unweighted signal-to-noise ratio > 41 dB acc. to DIN 45 500
Tonearm	Torsion-resistant aluminum tonearm in four-point gimbal suspension
Tonearm Bearing Friction	vertical < 0.007 p horizontal < 0.016 p
Pick-up Head	Detachable, suitable for all pick-up cartridges with Dual catch mounting and 1/2" mounting and a deadweight of 4.5 – 10 g (including hardware)
Tracking Force	0 – 3 p continuously variable, with 1/10 p calibration in the range from 0 – 1.5 p, reliable as from 0.5 p tracking force
Weight	approx. 4.2 kg

For dimensions and cutout refer to Installation Instructions.

Fig. 2 Motor and Drive

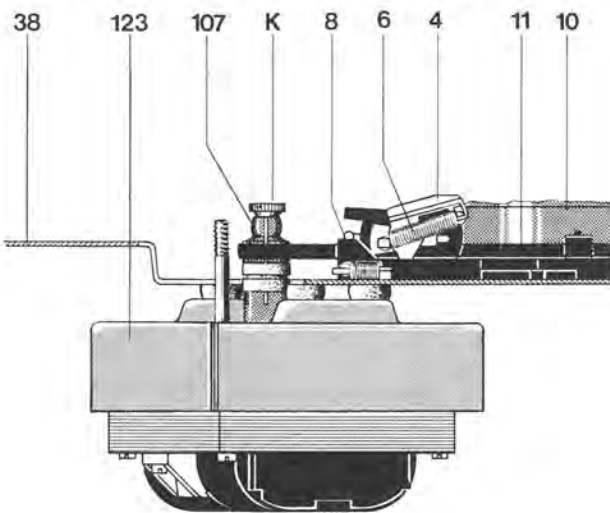

Fig. 3

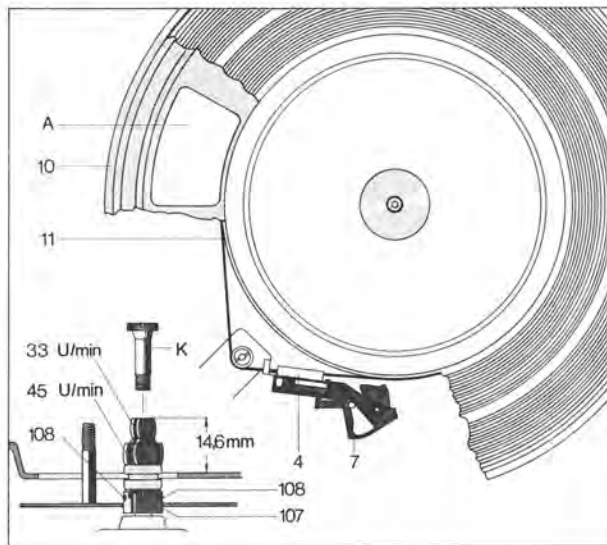
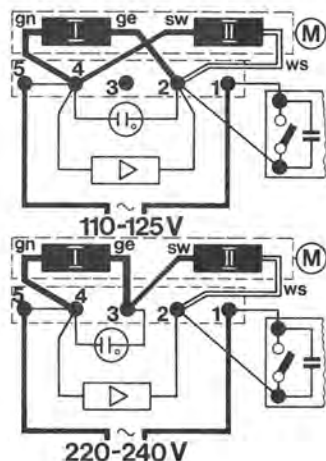

Fig. 4 Motor field coil connections



Motor and Drive

The turntable platter and the gear are driven by an 8-pole, synchronous motor (123) suspended by radially located elastic mounts and having a very small stray magnetic field as well as little vibration.

The speed of the motor is a function of line voltage, temperature and load variations. Speed is dependent on and proportional to line frequency. The motor is adapted to 50 or 60 Hz (cps) by the correct choice of motor pulley.

Pulley for 50 Hz, Part. No. 234 453
Pulley for 60 Hz, Part. No. 234 454

The drive is linked to the platter by a precision-ground belt (11). When replacing the flat belt (11) be sure that the precision-ground surface of the belt (dull finish) closely contacts the drive pulley (107) and the platter.

Platter speeds of 33 1/3 and 45 rpm are adjusted by linking the flat belt (11) to the corresponding step of the drive pulley (116) (Fig. 3).

Corresponding to the actuation of the speed selector (12) the control lever is brought to the appropriate position of nominal speeds (33 1/3 or 45 rpm) via the changeover lever (101). When the unit is electrically shut off the changeover is blocked by locking bar (7). Consequently, the speed is only preselected. After switching on the unit and turning the platter (10) the locking bar (7) disengages the changeover lever thus guiding the flat belt (11) to appropriate step of the pulley.

Replacement of Motor Pulley

1. Remove flat belt (11) from motor pulley (116). Undo machine screw (125) and slide back locking bar (126). Remove platter (10).
2. Loosen set screws (108) and pull off drive pulley (107).
3. Put complete replacement drive pulley on motor axle. Remove conical sleeve. Tighten set screws (108) uniformly. Place conical sleeve into the motor pulley (107).
4. Put platter (10) into bearing housing (157) and secure with lock bar (126). Retighten machine screw (125). Put the flat belt on the drive pulley.
5. Check nominal speed with the strobe disk. If necessary, readjust as described below.

Setting of nominal speed

Lift platter mat (3) above one of the recesses (A) and turn platter (10) by hand so that the drive pulley (107) becomes visible. Hold the drive pulley (107) and turn the conical sleeve (K).

If the nominal speed is too high, turn the conical sleeve (K) counterclockwise. If the speed is too low turn the conical sleeve clockwise.

Check by means of a strobe disk and repeat adjustment, if necessary.

Tonearm and Tonearm Bearing

The Dual 502 has a light, torsion resistant all-metal tonearm which is suspended in a gimbal. Suspension is by means of 4 hardened and precision polished steel points which rest in precision ball bearings. Tonearm bearing friction is thus reduced to a minimum

Bearing friction:
vertical $\cong 0.07$ mN (0.007 p)
Bearing friction:
horizontal $\cong 0.16$ mN (0.016 p)
related to stylus point.

As a result, it ensures extremely favorable pick-up conditions. Before adjusting the tracking force to suit the built-in pick-up cartridge the tonearm should be balanced with the scale set to 0. Coarse adjustment is carried out by moving the stem (50), the subsequent fine adjustment by turning the counterweight is designed so that pick-up cartridges with a deadweight (incl. hardware) of 4.5 to 10 g can be balanced. The tracking force is adjusted by turning the coil spring mounted in the spring housing (65). The spring housing is provided with a scale with markings (0 - 30 mN/0 - 3 p) which allow precise setting of tracking force. One division corresponds to 1 mN (0.1 p) within the range of 0.2 - 1.5 p, and 2.5 mN (0.25 p) within the range of 15 to 30 mN (1.5 - 3 p).

Removal of tonearm from bearing frame

1. Secure unit in repair jig. Remove weight (50). Unscrew straining screw (54) and set tracking force to zero (65).
2. Move unit into head position. Remove screening plate. Unsolder tonearm leads on the connecting plate (142).
3. With the unit in normal position screw the two mounting screws SW 4.5 - (57) counterclockwise to the stop in the frame (55).

Attention! Observe bayonet slide mounting. Slide tonearm rearwards and remove it from the bearing frame (55).

When reinstalling the tonearm proceed in reverse order.

Removal of tonearm assembly with tonearm bearing

Proceed as follows:

1. Secure unit in repair jig. Set tracking force scale (65).
2. Move unit into head position. Remove screening plate (144). Unsolder tonearm leads (142) on connecting plate (142).
3. Disengage compression spring (199) on bearing frame (yoke) (198). Turn bearing section (177) by 90° and remove it. Remove the setting bar (176).
4. Disengage tension spring (185), undo safety washer (192) and remove skating lever (191).
5. Remove safety washer (189) and sliding washer (188). Also remove shut-off bar (160) from segment (184).

Fig. 5 Tonearm bearing

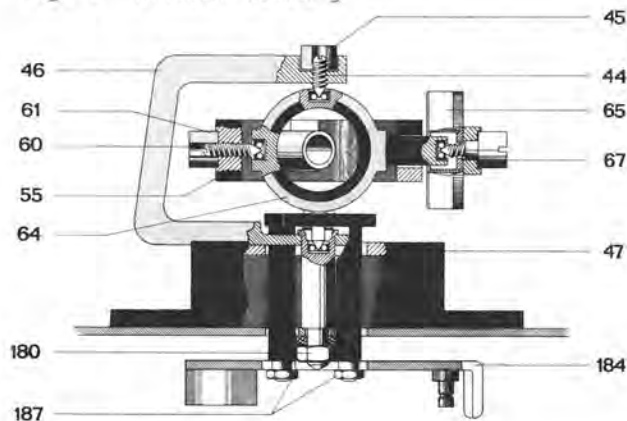

6. Undo hex nuts (187). Also remove segment (184).

7. Undo hex nut (180). Remove tonearm complete with bearing.

When attaching the tonearm proceed in reverse order. However, it should be properly adjusted when mounting the segment (184). (Refer to page 7).

Replacement of spring housing

Remove tonearm (49) from bearing frame as described above. Loosen lock nut and thread pin (44). Unscrew bearing screw (67). Observe left-handed thread! Lift bearing frame (55). Remove disk and spring housing (65). When installing the spring housing make sure that the helical spring catches the recess of bearing frame (55). Slide in washer (66). Tighten bearing screw (67). Reinstall tonearm (49). Using threaded pin (44) and lock nut (45) adjust bearing play as described below.

Fig. 6 Tonearm bearing (bottom view)

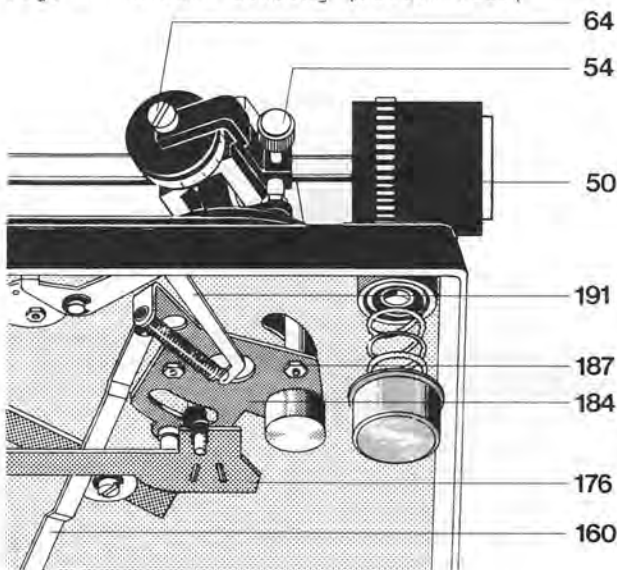

Adjustment of tonearm bearings

First balance tonearm exactly. Both bearings must have slight, just perceptible play. The horizontal tonearm bearing is correctly adjusted when at anti-skating settings "0.5" and being touched it slides in without resistance. The vertical tonearm bearing is correctly adjusted when it swings in after being touched. The play of the horizontal tonearm bearing should be adjusted with threaded pin (44), the play of the vertical tonearm bearing with threaded pin (60).

Fig. 7 Anti-Skating

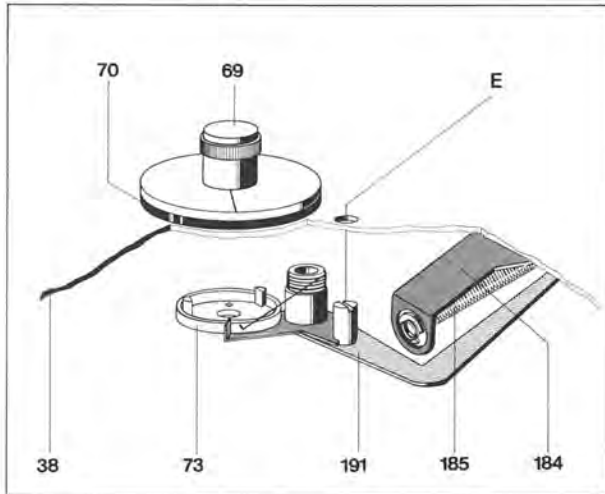

Anti-Skating Device

The anti-skating force is set by turning the pointer disk (69). According to the setting the asymmetrical cam plate (73) moves the skating lever (191) from its center of rotation. The anti-skating force is transmitted by the tension spring (185) to the segment (184) and, finally, to the tonearm (49).

Optimum adjustment is carried out by the manufacturer for styli with a tip radius of 15 μm (conical) and $5/6 \times 18/22 \mu\text{m}$ (elliptical) as well as for CD 4 pick-up cartridges. Alterations can be made only with the aid of the Dual Skate-0-Meter and the test record and should only be done by an authorized Dual Service Station.

Recheck as follows:

Balance tonearm (49). Set pointer disk to 0 (69). Now the tonearm should remain in any position of its moving range. The hole of the skating lever (191) should align the center line of the tonearm. This is adjustable with the eccentric pulley accessible through the hole in the mounting plate (38) between the pointer disk (69) and the bearing base (47) (Fig. 13).

The set knurled ring (69) to "0.5". Now the tonearm should return from the center of the platter to its rest (77).

Cue Control

The cue control permits gentle set-down of the tonearm at any desired point (outside the shut-off range) on the record.

By moving the lever (194) (moving forwards) lift cam (197) rotates. The slide bar (176) connected to it transmits this movement to the lift pin which then raises the tonearm.

After moving the tonearm into the desired position on the record. The lever is released

by gently moving to the rear. As a result, slide bar (176) is released and the tonearm lowers slowly. Lowering of the tonearm is damped by silicone oil in the lift pin.

The height of the stylus above the record can be varied by turning adjusting bush (179). The distance is reduced by turning clockwise. The distance between record and stylus can be increased by turning counter-clockwise. The distance preset by the factory is approx. 8 mm.

Fig. 8 Cue Control

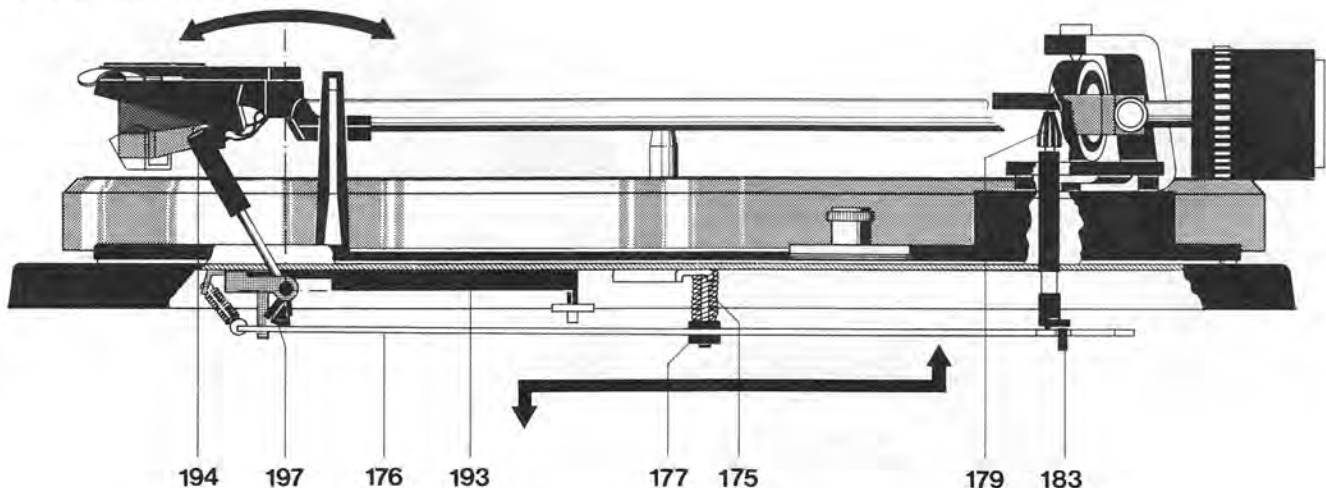

Replacement of Cue Control Assembly

1. Secure unit in repair jig, and lock to-nearm.
2. Move unit into head position.
3. Disengage compression spring (199) on bearing yoke (198). Turn bearing section (177) by 90° and remove it. Also detach slide bar (176).
4. Disengage tension spring (185), loosen lockwasher (192) and skating lever (191).
5. Remove lockwasher (189) and slide washer (188). Remove shut-off bar (160) from segment (184).
6. Loosen hex nuts (187). Remove segment (184).
7. Remove lockwasher (166) and washer (165), disengage catch (164).
8. Remove machine screw (181). Hold tonearm bearing. Unscrew hex nut (180) and complete cue control assembly (178).
9. Secure tonearm against dropping out using hex nut (206).

For installation of the cue control assembly (178) proceed in the reverse order. When mounting the segment (184) make sure that it is properly adjusted as described below.

Starting and Shut-off

Turning the tonearm (49) rotates the segment (184) thus actuating the power switch (127) via pawl (164) and shift arm (170) and starting motor (123) and platter (10) rotating.

The shut-off cycle after playing a record is initiated by the dog (M) of the platter (10) and shut-off lever (34).

The shut-off lever (34) is guided onto the dog by the movement of the tonearm when playing the record with the aid of the shut-off bar (160) proportionate to the groove lead.

The eccentrically mounted dog forces the shut-off lever (34) back with each revolution as long as the advance of the tonearm only amounts to the width of one groove (Fig. 17 a). Only the run-out groove with its increased lead guides the shut-off lever (34) onto the dog at a higher rate so that the shut-off lever is picked up and moves along (Fig. 17 b).

As a result, the shift arm is brought into its neutral position, the power switch interrupting power supply. Simultaneously, the lift actuating lever (170) coupled to the shift arm (170) is actuated and the tonearm (49) lifted.

Adjustment Points

1. Segment

- a) Lock tonearm (49). Move unit into head position. The center hole (L) of segment (184) should be centrally above the frame axis (46). The play between the pawl (164) and the stop (A) of segment (184) should be 0.3 to 0.5 mm. This is adjustable after loosening hex nuts (187) and by moving the segment (184).
- b) The shut-off point can be changed by the eccentric pulley on the segment (184). (Fig. 11).

Fig. 9

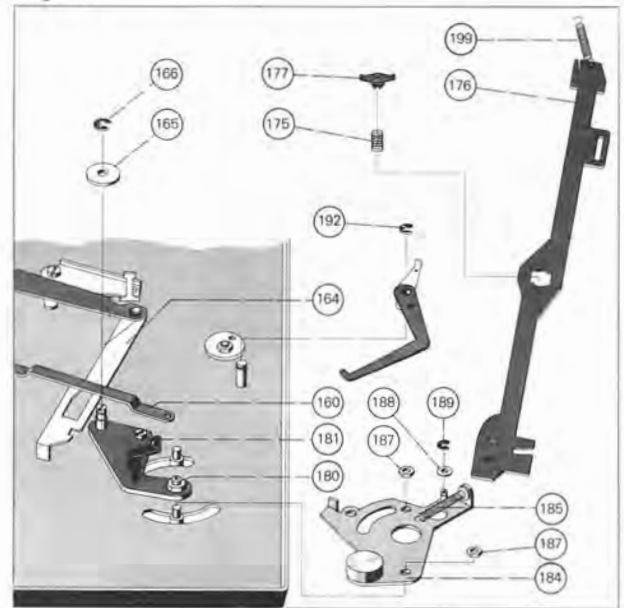

Fig. 10

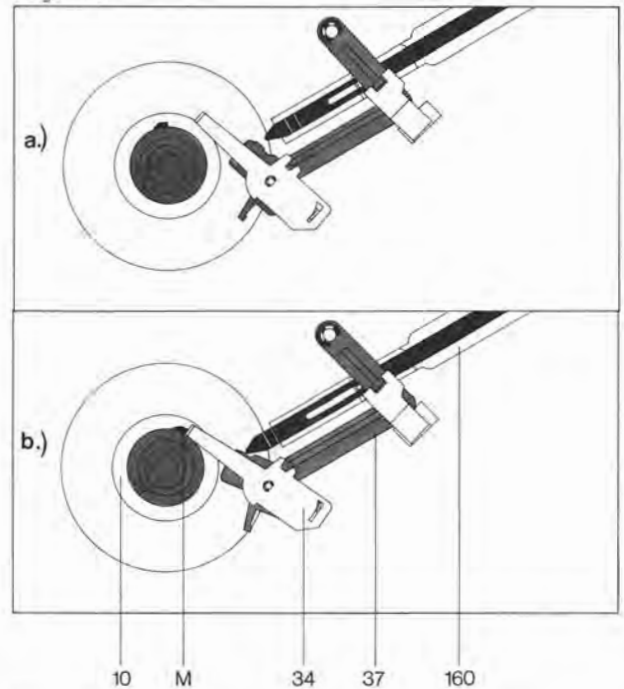

Fig. 11

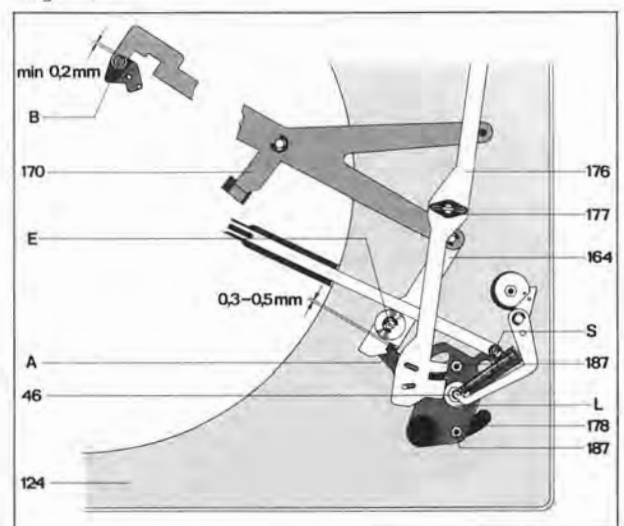

Fig. 12

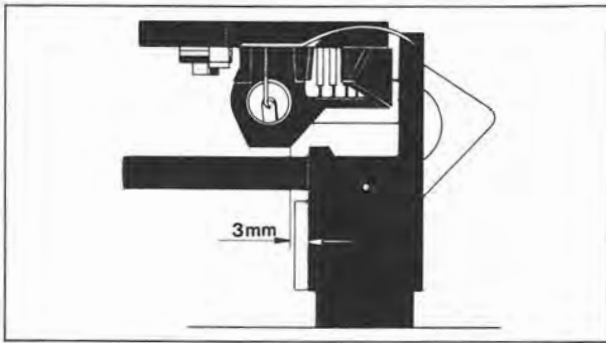
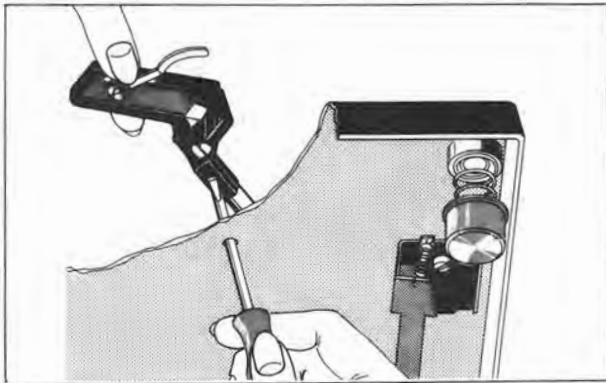

Fig. 13



Defect

Platter does not run after the power plug of the unit has been plugged into the power line receptacle and the tonearm moved inwards.

Platter does not come up to its required speed.

Stylus slips out of playing groove.

Tonearm does not lower on record or lowers onto record too quickly.

Acoustic feedback.

Cause

- a) Belt (11) not properly put on.
- b) Power supply to motor (123) interrupted.
- c) Drive pulley (107) slackened.

- a) Drive pulley (107) is not correct for local line frequency.
- b) Slippage between flat belt and drive pulley (107) or flat belt (11) and platter (10).
- c) Nominal speed maldjusted.

Steel ball (161) for shut-off bar missing.

Damping silicone oil in cue control tube excessive or too low.

- a) Chassis components (e.g. connecting leads) rubbing on board cut out.
- b) Connecting leads too tight.

2. Pawl

Move tonearm (49) inwards. The play between the stop pin (8) and the shift arm (170) and the mounting plate (124) should be 0.2 to 0.5 mm. Adjust by turning eccentric pulley (E), if necessary.

3. Power Switch

Extract power plug from receptacle! Move tonearm to its rest. Power switch should not switch off before the tonearm (49) is approx. 3 mm before its rest (Fig. 12). Adjust by bending the shift arm (146).

Defect

Pick-up head not parallel to platter.

Cause

The pick-up head has been moved out of position on the tonearm tube during transport.

Remedy

Remove platter. Using a screw driver slacken screw on the pick-up head through the hole provided for this purpose in the chassis plate. After aligning the pick-up head retighten screw.

Remedy

- a) Install belt properly put on.
- b) Check connection on switch plate (130) and power supply plug.
- c) Retighten drive pulley (107).
- a) Replace drive pulley (107).
- b) Clean friction surfaces of flat belt (11), drive pulley (107) and platter (10). Renew flat belt, if necessary.
- c) Readjust nominal speed.

Replace steel ball (161).

Remove cue control assembly (178) (refer to page 7). Unscrew adjusting bush (179), remove lift pin (183). Remove compression spring. Clean lift tube and lift pin and smear evenly with "Wacker Silicone Oil AK 500 000". Reassemble parts. Wipe off excessive silicone oil after assembly.

- a) Line up mounting board cut-out according to installation instructions.
- b) Slacken or lengthen leads.

Replacement Parts

Pos.	Part. No.	Description	Qty.
1	220 213	Centring disc	1
2	236 036	Washer	1
3	240 958	Turntable mat complete	1
4	234 428	Support assembly	1
5	210 472	Machine screw AM 3 x 4	5
6	232 086	Tension spring	1
7	237 220	Locking bar	1
8	234 814	Tension spring	1
9	210 194	"C" clip G 2 x 6	1
10	240 959	Turntable complete with mat	1
11	234 435	Flat belt	1
12	237 976	Speed control knob	1
13	240 960	Speed control blind compl.	1
14	213 260	Pin 2 x 6	6
19	239 414	Shipping screw compl.	3
20	210 146	Lock washer 3.2	8
21	201 632	Rubber washer	3
22	237 117	Washer	3
23	237 118	Lock washer	3
24	237 668	Special screw	3
26	237 223	Contact plate compl.	1
27	234 611	Handle	1
28	210 182	Bowed lock washer	1
29	210 630	Washer 4.2/8/D.5	1
30	210 197	"C" clip G 4 x 8	1
31	237 224	Tonearm head compl.	1
32	236 242	TK 24 Cartridge mount	1
33	210 142	Lock washer 1.2	1
34	234 766	Shut-off lever	1
35	210 146	Lock washer 3.2	8
36	234 764	Friction plate	1
37	234 762	Support	1
38	240 961	Chassis compl.	1
39	230 529	Threaded piece	4
40	236 710	Compression spring (Motor side rear)	1
	236 711	Compression spring (Motor side front)	1
	236 712	Compression spring (Tonearm side rear)	1
	236 713	Compression spring (Tonearm side front)	1
41	237 226	Spring mount compl. (Motor side rear)	1
	237 227	Spring mount compl. (Motor side front)	1
	237 228	Spring mount compl. (Tonearm side rear)	1
	237 229	Spring mount compl. (Tonearm side front)	1
42	200 723	Rubber damping block	4
43	200 722	Steel cup	4
44	234 635	Lock nut	2
45	234 651	Grub screw	1
46	240 962	Frame compl.	1
47	240 963	Cover compl.	1
48	239 193	Fillister head screw M 3 x 6	3
49	237 232	Tonearm compl.	1
50	240 964	Weight compl.	1
51	233 744	Yoke	1
52	236 160	Support plate	2
53	239 565	Machine screw M 2.5 x 3	2
54	238 461	Clamp bolt	1
55	240 966	Bearing rock	1
56	238 201	Plate	1
57	238 202	Fixing screw	1
58	238 623	Needle	1
59	237 672	Pin	1
60	234 635	Lock nut	2
61	230 063	Grub screw	1
62	236 049	Set screw	1
63	218 894	Lock washer	1
64	240 967	Bearing compl.	1
65	236 907	Spring housing compl.	1
66	237 563	Washer	1
67	237 564	Bearing screw	1
68	240 968	Anti-Skating compl.	1
69	238 183	Washer with needle	1
70	238 182	Numeral washer	1
71	200 444	Spring washer	2
72	216 867	Lock washer	1
73	225 176	Curve washer	1
74	210 362	Hex nut M 3	5
75	240 969	Cover front compl.	1
76	213 260	Pin 2 x 6	6

Fig. 14 Exploded view of parts above the chassis plate

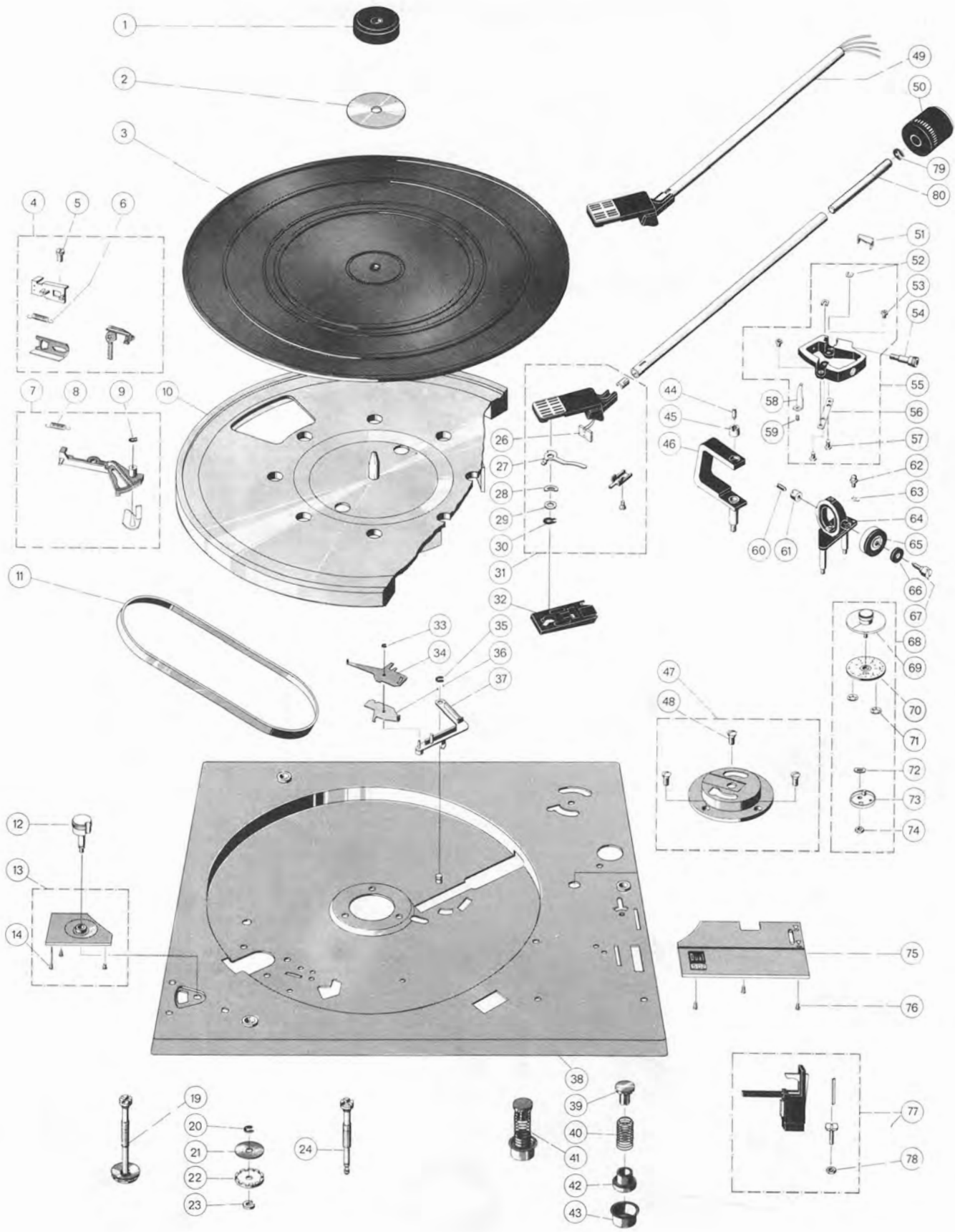
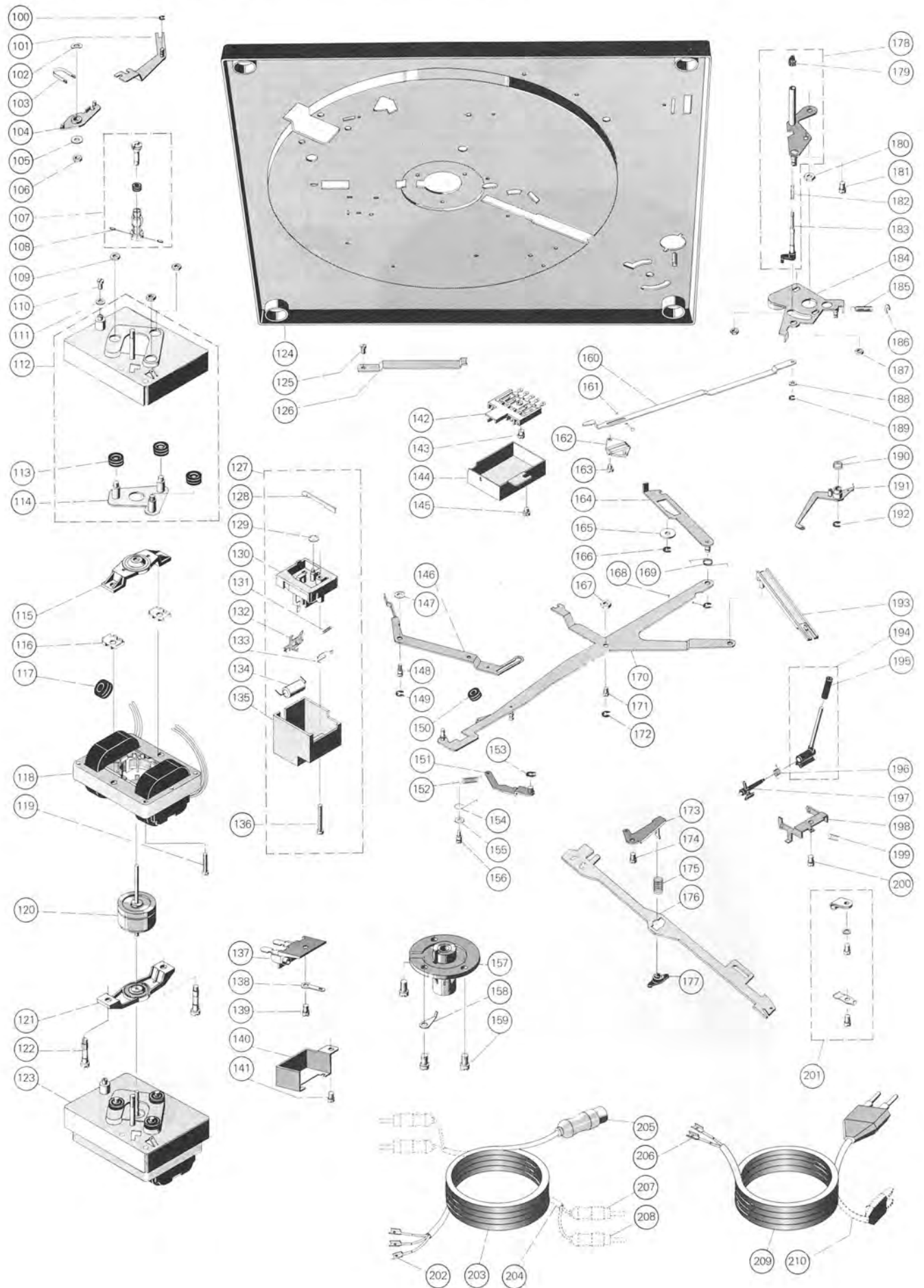

Fig. 15 Exploded view of parts below the chassis plate



Pos.	Part. No.	Description	Qty.
77	236 911	Tonearm rest compl.	1
78	210 362	Hex nut M 3	5
79	210 147	Lock washer 4.0	1
80	238 666	Stud	1
100	210 145	Lock washer	3
101	234 824	Switch lever	1
102	210 184	Lock washer	1
103	236 374	Yoke spring	1
104	238 177	Connecting part	1
105	210 586	Washer 3.2/7/0.5	1
106	210 362	Hex nut	5
107	240 972	Motor pulley 50 Hz compl.	1
	240 973	Motor pulley 60 Hz compl.	1
108	233 137	Grub screw M 2.5 x 3	2
109	210 366	Hex nut M 4	4
110	210 480	Machine screw M 3 x 6	1
111	210 609	Washer 3.2	1
112	232 856	Screen plate compl.	1
113	232 841	Rubber damping block	3
114	232 840	Inlayer compl.	1
115	234 447	Top bearing bracket compl.	1
116	232 855	Spacer	2
117	209 939	Cable grommet	1
118	234 449	Stator 110/220 V compl.	1
119	233 815	Machine screw M 2.5 x 18	1
120	234 450	Armature compl.	1
121	234 451	Bottom bearing bracket compl.	1
122	232 851	Centring crew	2
123	234 452	8-pole Motor SM 840 110/220 V compl.	1
124	240 961	Chassis compl.	1
125	210 472	Machine screw M 3 x 4	5
126	237 970	Holding bar	1
127	233 009	Power switch compl.	1
	236 607	Power switch compl. with Spec.-C.	1
128	236 335	Slide	1
129	200 444	Spring washer	1
130	233 012	Power plate compl.	1
	236 605	Power plate compl. with Spec.-C.	1
131	230 296	Tension spring	1
132	230 148	Switch slide	1
133	219 200	Snap spring	1
134	209 505	Capacitor 10 nF/1000 V/10 %	1
	230 355	Capacitor 68 nF/ 150 V/20 %	1
135	233 010	Cover	1
136	210 498	Machine screw	1
137	236 219	Cynch socket platte compl.	1
138	209 975	Soldering lug	1
139	210 475	Machine screw M 3 x 5	1
140	236 195	Shield	1
141	210 472	Machine screw M 3 x 4	5
142	237 238	TA-connecting plate compl.	1
143	210 480	Machine screw M 3 x 6	1
144	236 080	Shield	1
145	210 472	Machine screw M 3 x 4	5
146	238 178	Switch slide	1
147	210 607	Washer 3.2	1
148	234 759	Screw pin	1
149	210 146	Lock washer 3.2	8
150	236 950	Rubber damping block	1
151	234 760	Stop lever	1
152	234 799	Tension	1
153	210 916	"C" clip 3	1
154	237 785	Wire spring	1
155	210 586	Washer 3.2/7/0.5	1
156	234 759	Screw bolt	1
157	237 236	Support housing compl.	1
158	236 759	Earth spring	1
159	210 515	Machine screw M 4 x 6	3
160	234 807	Shut-off bar	1
161	209 357	Steel ball 3	1
162	232 104	Ball bearing (bead)	1
163	210 469	Machine screw M 3 x 3	3
164	234 786	Catch	1
165	210 643	Washer 4.2/12/1	1
166	210 146	Lock washer 3.2	8
167	210 362	Hex nut M 3	5
168	210 145	Lock washer 2.3	4

Pos.	Part. No.	Description	Qty.
169	234 789	Post spring	1
170	234 756	Shiftarm	1
171	234 759	Screw pin	1
172	210 146	Lock washer 3.2	8
173	237 969	Bearing slide	1
174	210 469	Machine screw M 3 x 3	3
175	237 974	Compression spring	1
176	234 783	Slide bar	1
177	237 975	Bearing	1
178	237 239	Lift plate compl.	1
179	234 800	Adjustment sleeve	1
180	210 366	Hex nut M 4	4
181	210 472	Machine screw M 3 x 4	5
182	234 798	Compression spring	1
183	234 795	Lifting bolt compl.	1
184	240 970	Segment compl.	1
185	218 591	Tension spring	1
186	201 184	Adjustment washer	1
187	210 362	Hex nut M 3	5
188	201 187	Sliding washer	1
189	210 145	Lock washer 2.3	4
190	229 688	V-spring	1
191	238 192	Skating lever	1
192	210 146	Lock washer	8
193	234 780	Lift actuating lever	1
194	240 893	Lift mave	1
195	237 543	Rubber sleeve	1
196	234 778	Torsion spring	1
197	234 777	Lift cam	1
198	237 972	Support bracket	1
199	233 710	Tension spring	1
200	210 469	Machine screw M 3 x 3	3
201	231 079	Cable holder compl.	1
202	209 436	Socket for flat prong	3
203	207 303	Pick-up lead compl. with cynch plug	1
204	226 817	Pick-up lead compl. with miniatur and flat plug ..	1
205	209 424	Miniature plug	1
206	214 602	AMP-connector	2
207	209 425	Cynch plug withe	2
208	209 426	Cynch plug black	2
209	232 996	Power lead Europe compl.	1
210	232 995	Power lead US compl.	1
***	214 120	Hardware for cartridge mounting	1
***	238 409	Mounting instructions	1
***	238 408	Operating instructions	1
***	238 969	Operating instructions UAP	1
***	240 971	Shipping carton 502	1
***	236 920	Shipping carton CS 502	1

Lubrication

All bearing and friction points of the unit are adequately lubricated at the works. Replenishment of oil and grease is only necessary after approximately 2 years of normal use of the record player as the most important bearing points (motor bearings) have sintered metal bushes.

Bearing points and friction faces should be lubricated sparingly rather than generously.

It is important that no oil grease should come in contact with the friction faces of the flat belt, drive pulley and flywheel rotor, otherwise slip will occur.

When using different lubricants, chemical decomposition can often take place. To prevent lubrication failure we recommend using the original lubricants stated below.

2

Renotac No. 342 adhesive oil

3

BP Super Viscostatic 10 W/30

4

Shell Alvania No. 2

5

Isoflex PDP 40

6

Silicone oil AK 500 000

Fig. 16

