

601
Download from www.dual.de
Not for commercial use
Dual

601

Edition August 1975



Service Manual

Dual Gebrüder Steidinger · 7742 St. Georgen/Schwarzwald

Fig. 1 Pick-up Connection Diagram

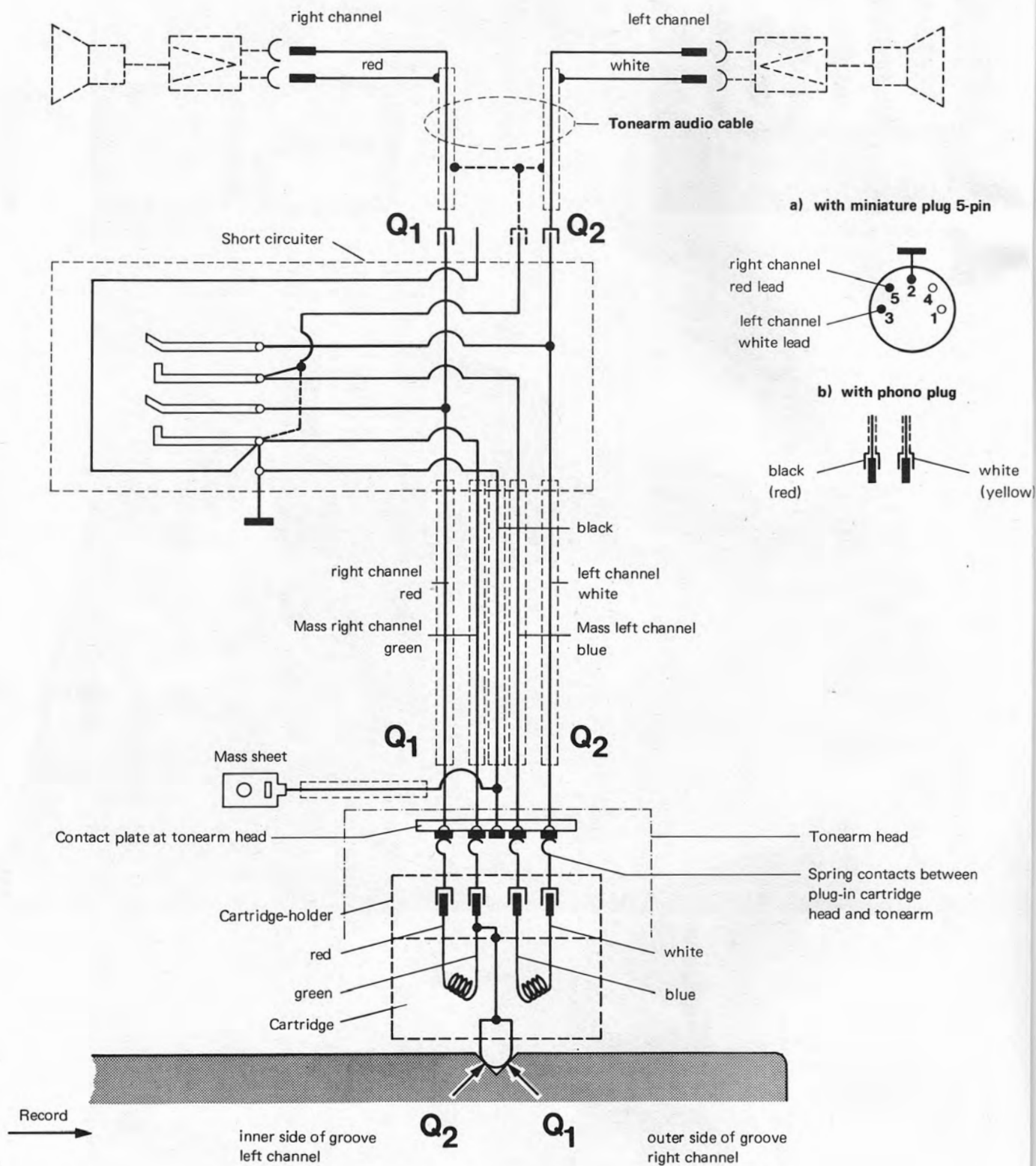

Contents

	Page
Pick-up Connection Diagram	2
Specification	3
Motor and Drive	4
Replacement of Motor Pulley	4
Stroboscope	5
Pitch Control	6
Nominal speed is at the edge of the control range of the pitch/control	6
Platter does not run when unit is connected to power line and start switch operated	6
Platter does not reach required speed	6
Pick-up head not parallel to platter	6
Tonearm and Tonearm Bearing	7
Anti-skating Device	8
Stylus skips	8
Vertical tonearm movement shows resistance during set down	8
Tonearm Control	9
Cue Control	9
Replacement of Lift Tube	10
Tonearm does not set down at the edge of the record	10
Tonearm does not set down on record after operating cue control	10
Tonearm lowers onto record too quickly when cue control is operated	10
Tonearm returns to rest after manual set down immediately after the platter starts to turn	10
Starting	11
Manual Start	11
Short Circuiter	11
Continuous play	11
Stopping	12
Shut-off	12
Platter remains stationary after automatic set-down of tonearm on record	12
Tonearm remains suspended just outside the 17.5 cm record after adjustment of the tonearm set-down point for 30 cm records	13
Tonearm is hindered in its horizontal motion during automatic operation	13
Tonearm moves with tracking force and anti-skating scale in 0 position	13
During automatic operation of tonearm disturbing noises are perceptible	13
No reproduction	13
Motor does not shut off when tonearm sets down on rest	13
Acoustic Feedback	13
Spare parts with Exploded drawings	14 - 19
Lubricating Instructions	20

Specification

Current Type	AC 50, 60 Hz, selected by exchanging drive pulley
Line Voltages	110 – 130 volts, 220 – 240 volts
Motor and Drive	8-pole/synchronous motor with belt drive system
Power Consumption	approx. 10 watts
Current Consumption	with 220 V 50 Hz approx. 72 mA with 110 V 60 Hz approx. 135 mA
Platter	Non-magnetic, dynamically-balanced, detachable, 1,3 kg, 305 mm dia
Platter Speeds	33 1/3 and 45 rpm, automatic tonearm lowering coupled to speed change
Pitch Control	Range of adjustment approx. 1 semitone (6 %) at both platter speeds
Speed Check	with light stroboscope for platter speeds of 33 1/3, adjustable for 50 or 60 Hz
Overall Speed Variation	(assessed in accordance with DIN 45 507) $< \pm 0.08$
Signal-to-Noise Ratio	Rumble weighted signal-to-noise ratio > 63 dB
	Rumble unweighted signal-to-noise ratio > 42 dB (in accordance with DIN 45 500)
Tonearm	Torsion resistant, tubular aluminum tonearm in universal four-point gimbal suspension
Tonearm Bearing Friction (related to stylus point)	vertical < 0.007 p
	horizontal < 0.015 p
Pick-up Head	Detachable, suitable for all pick-up cartridges with Dual catch mounting and 1/2" mounting and a deadweight of 2 – 10 g (including mounting material)
Tracking Force	0 – 3 p continuously variable, with 1/10 p calibration in the range from 0 – 1.5 p, reliable as from 0.25 p tracking force
Weight	approx. 5.3 kg
	For dimensions and cutout refer to Installation Instructions

Fig. 2 Motor and Drive

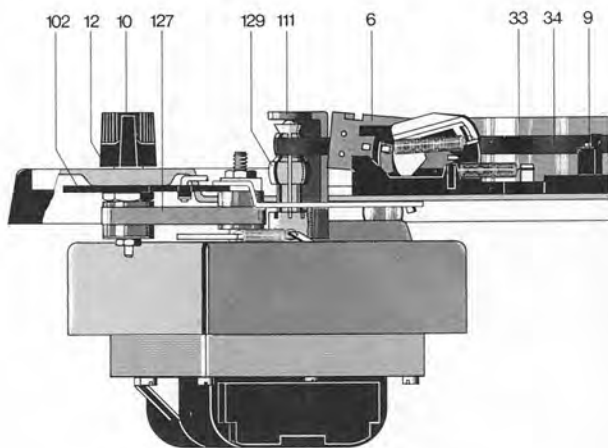

Fig. 3

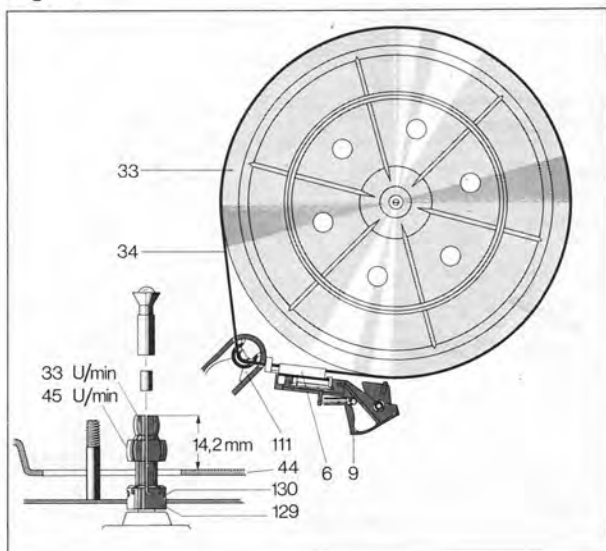
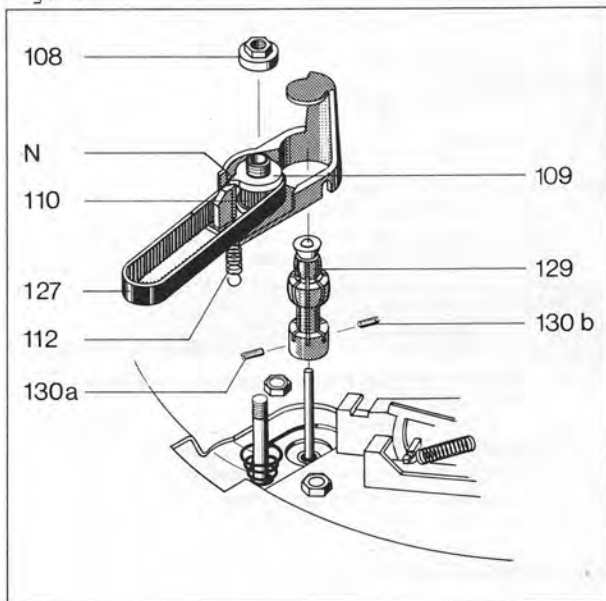

Fig. 4



Motor and Drive

The turntable platter and the changing mechanism are driven by an eight-pole, synchronous motor suspended by radially located elastic mounts and having a very small stray magnetic field as well as little vibration.

The speed of the motor is a function of line voltage, temperature and load variations. Speed is dependent on and proportional to line frequency. The motor is adapted to 50 or 60 Hz power line frequencies by the correct choice of motor pulley.

Pulley for 50 Hz Part.-No. 224 453
Pulley for 60 Hz Part.-No. 234 454

The motor pulley (129) is secured to the motor shaft by two set screws (130).

The drive is linked to a flywheel rotor beneath the platter by a precision-ground belt (34). When replacing the flat belt (34) be sure that the precision-ground surface of the belt (dull finish) closely contacts pulley (129) and the flywheel rotor.

Platter speeds of 33 1/3 and 45 rpm are adjusted by linking the flat belt (34) to the corresponding step of the drive pulley (129) (Fig. 3).

Corresponding to the actuation of the speed selector (12) the changeover lever is brought to the appropriate position of nominal speeds (33 or 45 rpm) via lever (101) and spring lever. When the unit is electrically shut off the changeover lever is blocked by locking bar (9). Consequently, the speed is only preselected. After switching on the unit and turning the platter (4) the pawl (9) disengages the changeover lever, thus guiding the flat belt to appropriate step of the pulley (129).

Replacement of Motor Pulley

1. Remove flat belt (34) from motor pulley (129) toothed belt from toothed belt pulley II (104).
2. Disengage tension spring (112) at shield (116).
3. Undo adjusting nut (108).
4. Pull-off the center bearing assembly consisting of the center bearing, toothed belt pulley I (110), stop disk (109) and toothed belt (127).

Attention:

Do not remove stop disk (109) from toothed belt pulley I. For correct adjustment of stop disk proceed as follows: Turn toothed belt pulley I (110) with toothed belt (34) counterclockwise until it stops at the counter bearing (116). Then turn quarter to half turn clockwise. Place stop disk (109) such that the nose (N) touches the stop as shown in Fig. 2.

5. Loosen set screws (130 a and 130 b) and remove motor pulley (129).
6. Place complete replacement motor pulley on motor axle. Remove conical sleeve. Be careful with the interior distance bushing. Adjust motor pulley vertically (see Fig. 1) and tighten set screws (130 a and 130 b) uniformly. Place conical sleeve into the motor pulley (129).
7. Mount the complete bearing assembly, and attach flat belt (34), toothed belt (127) and tension spring. Mount adjusting nut (108).

8. Setting of nominal speed

To bring stop disk into center position turn adjustment knob correspondingly. (The nose of the stop disk should show to the motor pulley center).
Adjust nominal speed by turning adjusting nut (108) counterclockwise the speed is reduced. When turning it clockwise the speed is increased.

Stroboscope

Accurate setting of the platter speed 33 1/3 rpm can be checked during play with the aid of the stroboscope device.

When the platter (4) is rotating at exactly 33 1/3 rpm the lines of the stroboscope appear to stand still. If the lines of the stroboscope move in the direction of rotation of the platter, the platter speed is too high. If the lines move backwards, the platter is rotating more slowly than the nominal speed.

Adjustment is carried out with the "pitch" knob (10).

To change the stroboscope slacken machine screws (241), move stroboscope housing (243) to "50" or "60" (Hz) and retighten screws. After removing the housing top (238) the glow lamp (239) can be changed. In the case of glowlamps with red spot ensure that the red spot (anode) faces the C 1 capacitor.

Defect

After switching the unit on the glow lamp (239) of the stroboscope does not come on.

Cause

- a) Glow lamp (239) defective
- b) Power supply interrupted

Remedy

- a) Renew glow lamp (239). In the case of glow lamps with red spot, ensure that the red spot (anode) faces the C 1 capacitor.
- b) Check connections at power pack, check components.

Fig. 5

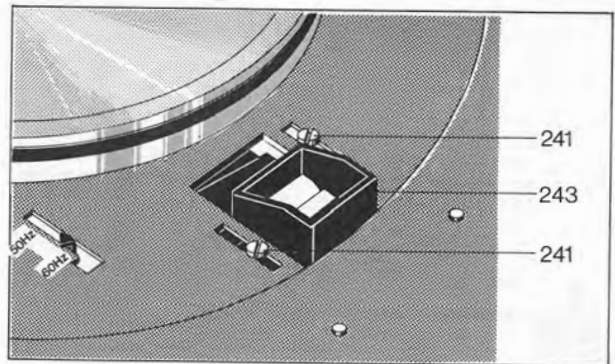

Fig. 6

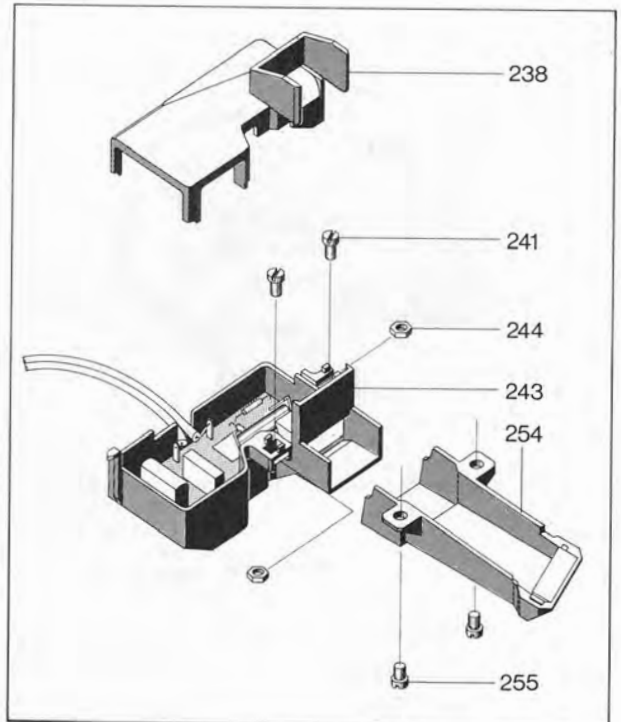

Fig. 7
Motor field connections
(with voltage selector)

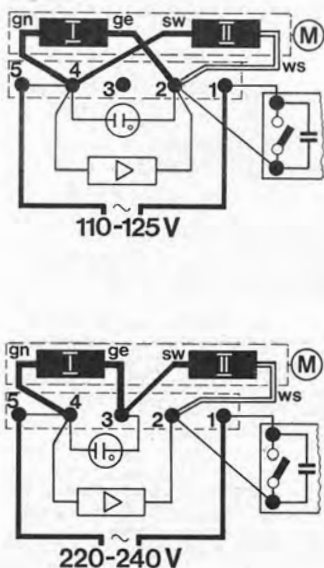
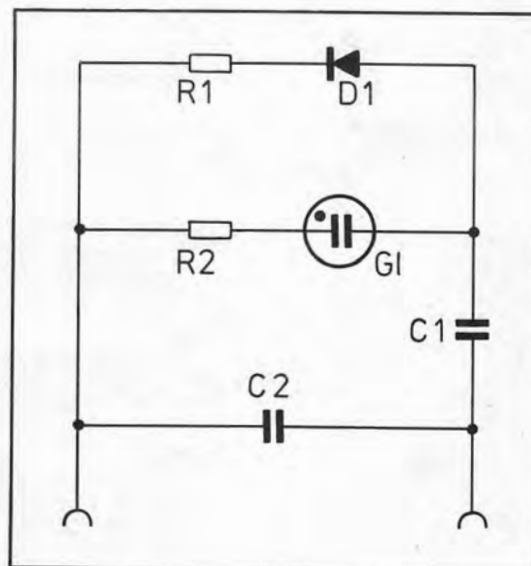

Fig. 8 Stroboscope (wiring diagram)



Circuit board
(output stages)

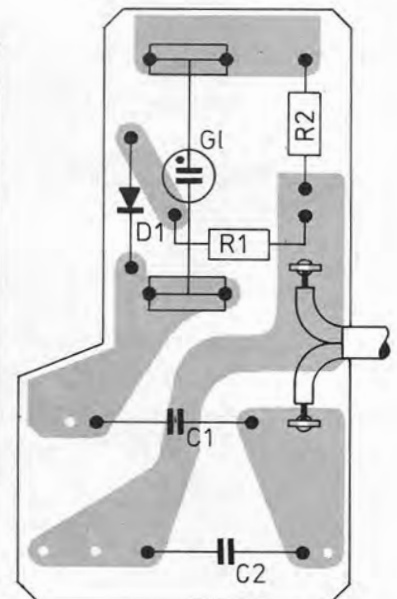
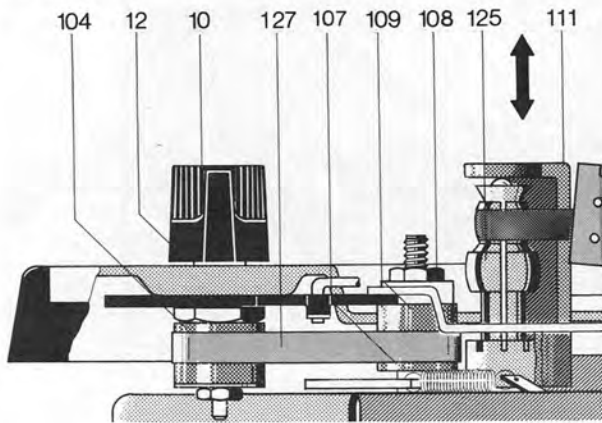

Fig. 9



Pitch Control

The unit has a separately adjustable pitch control by which the two standard speeds 33 1/3 and 45 rpm can be varied by approximately 6% (1 semitone).

By turning the fine speed adjustment knob (10) the toothed belt (Fig. 7) thus moving the counter bearing (111) upwards or downwards. The taper bush of the drive pulley (129) is designed to vary the diameter of the drive pulley (129) thus varying the nominal speed within the tolerance of $\pm 3\%$.

Defect

Nominal speed is at the edge of the control range of the pitch control.

Cause

Position of toothed belt pulley inaccurate.

Remedy

By turning fine speed adjustment knob (10) move stop disk (109) to its center position (The dog of the stop disk should face the center of the drive pulley). Using adjusting nut (108) adjust for nominal speed. The nominal speed is increased by turning the adjusting nut (108) clockwise and decreased by turning the set screw counterclockwise.

Platter does not run after the line voltage cord of the unit has been plugged into the receptacle and the master operating switch moved to "start".

- a) Power supply to motor interrupted
- b) Drive pulley slackened

- a) Check connection at switch plate and power supply plug.
- b) Retighten drive pulley

Platter does not come up to its required speed.

- a) Drive pulley is not correct for local line frequency
- b) Slippage between flat belt and drive pulley or between flat belt and flywheel rotor
- c) Excessive friction in motor bearing or flywheel rotor bearing assembly (161)

- a) Renew drive pulley

- b) Clean friction surfaces of flat belt, drive pulley and flywheel rotor. Renew flat belt if necessary. Once the flywheel rotor has been cleaned do not touch it with your fingers.

- c) Clean and oil bearings

Fig. 10

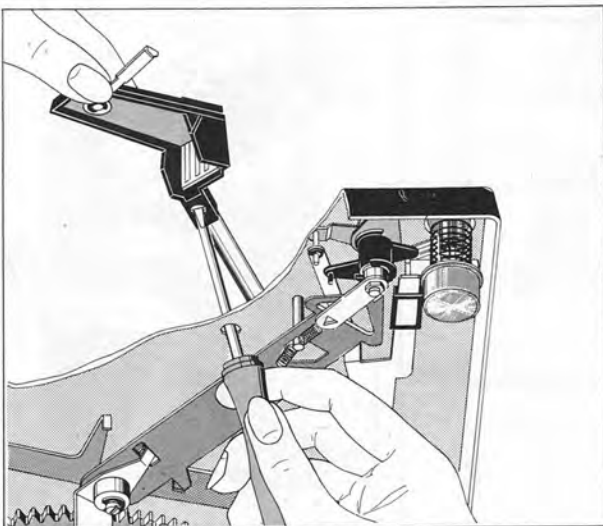

Defect

Pick-up head not parallel to platter.

Cause

The pick-up head has been moved out of position on the tonearm tube during transport.

Remedy

Remove platter. Using a screwdriver slacken screw on the pick-up head through the hole provided for this purpose in the chassis plate. After aligning the pick-up head retighten screw (Fig. 10).

Tonearm and Tonearm Bearing

The Dual 601 has a feather-light, extremely torsion-resistant all-metal tonearm which is suspended in a gimbal. Suspension is by means of 4 hardened and precision polished steel points which rest in precision ball bearings. Tonearm bearing friction is thus reduced to a minimum.

Bearing friction vertical $\cong 0.007$ p
 Bearing friction horizontal $\cong 0.015$ p
 related to stylus point

As a result, it ensures extremely favourable pick-up conditions. The pick-up head is removable. Before adjusting the pick-up force to suit the built-in pick-up cartridge the tonearm is balanced with the scale set to 0. Coarse adjustment is carried out by moving the counterweight (52) with stem (51), the subsequent fine adjustment by turning the weight.

The balance weight is designed so that pick-up cartridges with a deadweight of 2 - 10 g can be balanced. For the absorption of vibration and rapid small shocks, the counterweight is flexibly connected to its threaded stem and arrested to prevent unintentional rotation. The pick-up head is suitable for accommodating all pick-up cartridges whose type of mounting conforms with the international standard 1/2 inch mounting and whose deadweight does not exceed 10 g. The tracking force is adjusted by turning the graduated spring housing (59) and thus tensioning or releasing the coil spring mounted inside.

To change the tonearm complete with tonearm suspension we recommend proceeding as follows:

1. Secure unit in repair jig and arrest tonearm.
2. Move unit into head position and unsolder tonearm leads.
3. Remove main lever (154) and compression spring (180).
4. Disengage tension spring (260), undo washer (268) and remove skating lever (265). Be careful with compression spring (267) as it may drop out.
5. After removing washer (264) and sliding washer (263) detach shut-off bar (262) from segment (258).
6. Undo hexagon nut (259) and pull off segment (258).
7. Remove hexagon nut (217) and washer (67), then with draw tonearm complete with suspension.

When inserting the tonearm complete with suspension proceed in reverse order.

To remove the tonearm from the bearing race the tracking force scale should first be set to zero position after unsoldering the tonearm leads. Unscrew locknut (60) with grub screw (51) and mounting screw (65). Carefully withdraw tonearm from the bearing race. For adjusting the tonearm head, a hole is provided in the chassis to make this possible without first removing the tonearm.

Adjustment of Tonearm Bearing

Both bearings must have slight, just perceptible play. Adjustment of the vertical bearing should only be carried out by means of the left mounting screw (grub screw 61), that of the horizontal bearing by means of grub screw (36). The horizontal tonearm bearing is correctly adjusted when at antiskating setting "0.5" (tonearm previously balanced exactly) the tonearm slides in without resistance.

Fig. 11 Tonearm bearing assembly

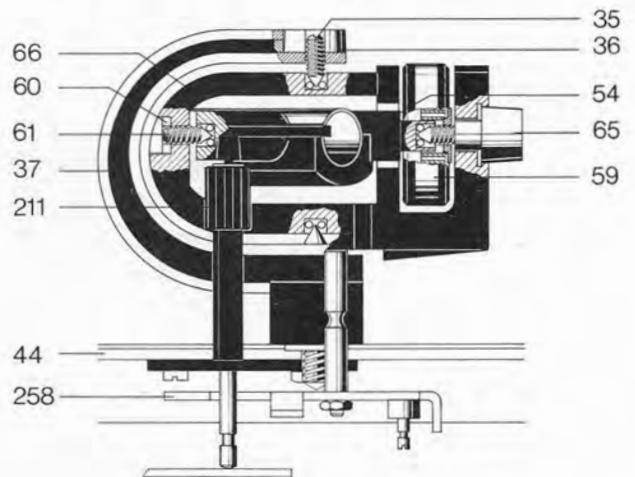

Fig. 12 Tonearm bearing assembly (view from underneath)

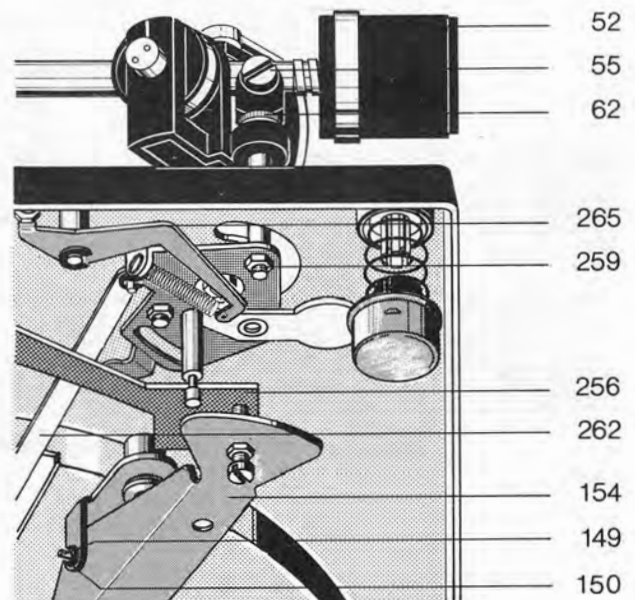
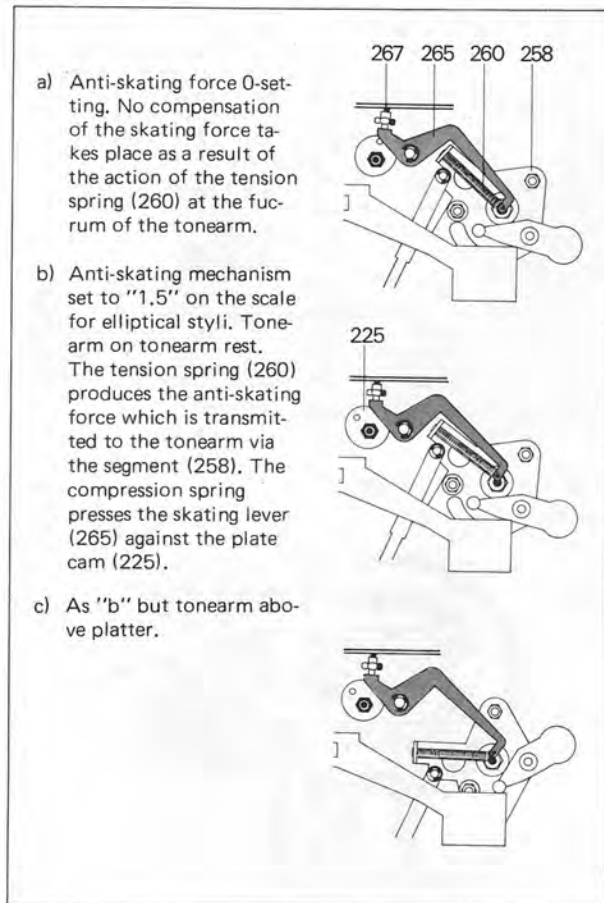

Fig. 13 Anti-skating force



Anti-Skating Device

The geometrical skating force acting on every tonearm is eliminated on the Dual 601 by means of a precision anti-skating device. The skating force is dependent on the geometry of the tonearm, on the tracking force and on the tip curvature of the stylus of the pick-up cartridge. The pull on the tonearm to the center of the platter caused by the skating effect leads not only to troublesome jumping of the tonearm when lowered manually or automatically, but also the uneven flank loading of the sound groove with the resultant effects which have to be eliminated on a hifi record player with the aid of the anti-skating device.

Turning the knob (69) of the anti-skating device on the mounting plate moves the asymmetrical plate cam (225). This plate cam has two different curves which, according to use of the red anti-skating scale for the different styli as well for CD 4 pick-up cartridges move the skating lever (265) from its neutral position and transmit the counter force to the tonearm by means of tension spring (260).

Optimum adjustment is carried out at the works for styli with a tip radius of $15 \pm 2 \mu\text{m}$ (conical) and $5/6 \times 18/22 \mu\text{m}$ (elliptical) as well as for CD 4 pick-up cartridges. The hexagon nut (226) is tightened and locked with paint. Alteration can only be carried out with the aid of the Dual Skate-0-Meter and test record L 096 and should only be done by an authorised service station.

Defect

Stylus slips out of playing groove

Cause

- Tonearm is not balanced
- Tonearm tracking force is too low
- Anti-skating setting incorrect
- Stylus tip worn or chipped
- Excessive bearing friction in tonearm bearing

- Steel ball (221) of shut-off bar missing

Vertical tonearm movement shows resistance during set-down

- Bearing friction excessive
- Lift pin (216) sticks in guide tube

Remedy

- Balance tonearm
- Check tonearm balance, adjust tracking force to the value stated by the cartridge manufacturer
- Correct anti-skating setting
- Renew stylus
- Check tonearm bearings. Both bearings must have slight, just perceptible play. The adjustment of the vertical bearing should only be carried out with the left-hand bearing screw (grub screw 61), that of the horizontal bearing by means of grub screw (36). The horizontal bearing is correctly adjusted when at anti-skating setting "0.5" (onearm previously balanced exactly) the tonearm slides in without resistance.
- Renew steel ball (221)

- Eliminate friction by adjusting the bearing screw (grub screw 36) and check balance
- Remove lift tube assembly as described on page 10. Remove guide (210) on lift pin (216). Remove lockwasher (212), detach adjuster sleeve (211) and remove second lockwasher (212). Withdraw lift pin evenly with "Wacker Silicone Oil AK 500 000". Reassemble components.

Tonearm Control

Automatic movement of the tonearm is initiated by the control cams on the inside of the cam wheel (144) on rotating through 360°.

The control elements for raising and lowering are the control lever (154) and lift pin (216), for horizontal movement of the tonearm control lever (154) with segment (258).

The automatic tonearm set down is designed for 30 cm and 17 cm records and is coupled to the platter speed changeover. The set-down points of the tonearm are determined by the spring pin of segment (258) contacting the positioning slide (256). Limitation of the horizontal movement of the tonearm is produced by the pin of segment (258) contacting the stop attached to the slide bar (256). Only during set-down does control lever (154) lift the slide bar (256) and the stop attached to it which, as a result, moves into the swivel range of the stop pin fitted on the segment. After completion of set down (lowering of the tonearm onto the record) the slide bar (256) is released again and returns to neutral position. As a result the stop moves out of the swivel range of the stop pin so that unimpeded horizontal movement of the tonearm is possible for playing.

Fig. 14 Tonearm guide mechanism

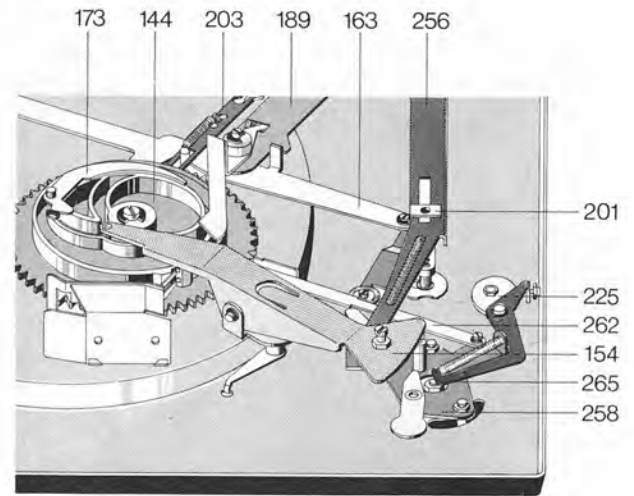

Cue Control

The cue control permits gentle set-down of the tonearm at any desired point (outside the shut-off range) on the record.

By moving the lever (41) (moving forwards) lift cam (249) rotates. The slide bar (256) connected to it transmits this movement to the lift pin which then raises the tonearm. After moving the tonearm into the required position on the record, the lever is released by gently moving to the rear. As

a result, slide bar (256) is released and the tonearm lowers slowly. Lowering of the tonearm is damped by silicone oil in the lift tube.

The height of the stylus above the record can be varied by turning adjusting screw (70) within the range 0 - 6 mm. The distance is increased by turning clockwise and the distance between record and stylus can be reduced by turning anti-clockwise.

Fig. 15 Tonearm lift (tonearm raised)

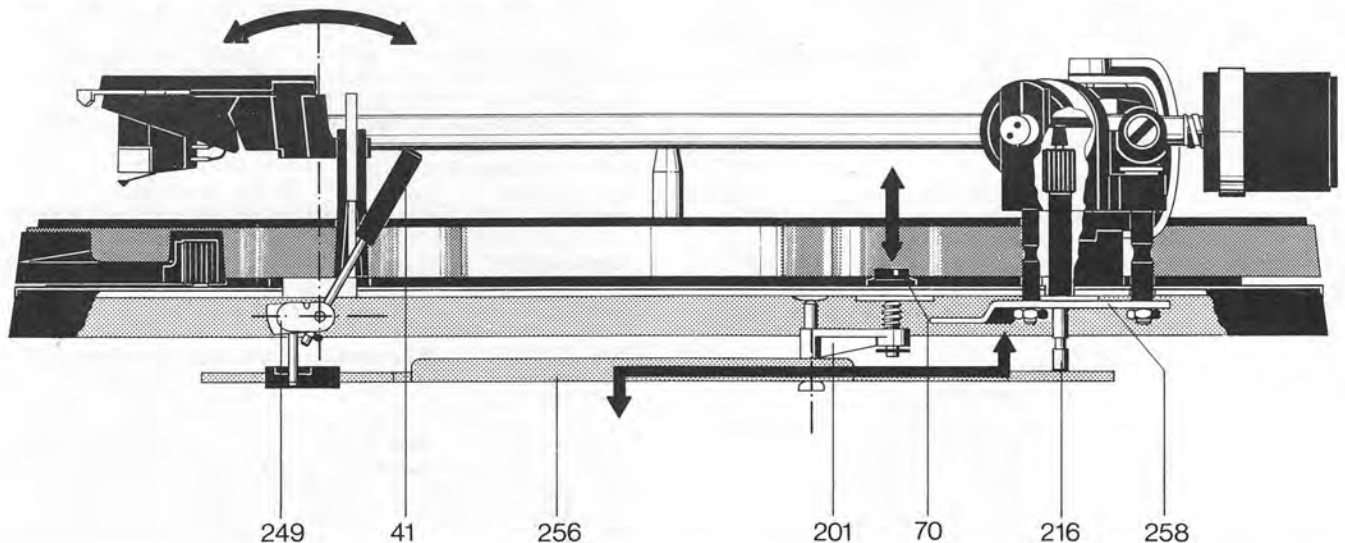
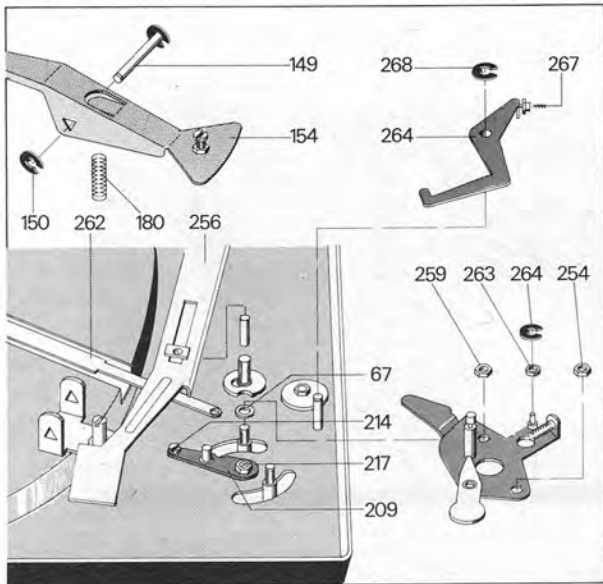

Fig. 16



Replacement of Lift Tube

1. Secure unit in repair jig, set stylus force to 0 and lock tonearm.
2. Move unit into head position. Detach main lever (154) and compression spring (180).
3. Disengage tension spring (260), undo locking washer (268) and detach skating lever (265). Be careful with compression spring (267) as it may drop out.
4. After removing lock washer (264) and sliding washer (263) detach shut-off bar (262) from segment (258).
5. Remove lock washer (202). Turn set screw (70) until bearing (201) and bar (256) are accessible.
6. Undo hexagon nut (259) and detach segment (258). Be careful with washer (67) as it may drop out.
7. Hold tonearm bearing and remove hexagon nut (217). Undo machine screw (214) and detach lift tube assembly (209).
8. Secure tonearm with hexagon nut (217).

Cause

Tonearm does not set down at the edge of the record

Defect

- a) Tonearm set-down point is incorrectly set
- b) Record non-standard
- c) Friction face of tonearm coupling dirty
- d) Anti-skating setting is incorrectly set

Tonearm does not set down on record after operating cue control

Excessive damping in the lift tube as a result of contamination of the silicone oil.

Tonearm lowers onto record too quickly when cue control is operated.

Damping insufficient as a result of unsuitable addition of lubricant to damping compound.

Tonearm returns to rest after manual set-down immediately after the platter starts to turn.

Position of shut-off has altered during transport of the unit

Remedy

- a) Set control lever (12) to 33 rpm. The adjusting screw in the hole under control lever (45) will be exposed. Then place a 30 cm record on the platter and start the unit. If the stylus sets down too far in, the adjusting screw should be turned anti-clockwise, if the stylus sets down too far out, the screw should be turned clockwise (Adjustment is only carried out with 30 cm records, the setting then being corrected automatically for 17.5 cm records).
- b) Use standard record
- c) Clean friction surfaces
- d) Correct anti-skating setting

Remove lift tube assembly as described above, detach control stud on the lift pin, remove safety washer (212), detach adjusting sleeve and second washer (211). Withdraw lift pin (216), clean lift pin and lift tube. Smear lift pin evenly with "Wakker Silicone Oil AK 500 000". Reassemble components. Wipe off surplus silicone oil after assembly.

Remove lift tube assembly as described above detach control stud on the lift pin, remove lockwasher (212), detach adjusting sleeve and second washer (211). Withdraw lift pin (216), clean lift pin and lift tube. Smear lift pin evenly with "Wakker Silicone Oil AK 500 000". Reassemble components. Wipe off surplus silicone oil after assembly.

After fitment and each time after transport the unit should be started once with tonearm secured for automatic adjustment of automatic shut-off (control lever (45) to "Start").

Starting

Change lever (45) is rotated clockwise when the left hand control lever (189) is operated. This results in the following functions being initiated:

- a) Change lever (189) rotates the shift arm (163) mounted on groove pin (198). Simultaneously the power switch is operated by the shut-off lever (165) coupled to the shift arm (163). Thus starting the motor and platter rotating.
- b) The change lever (189) is moved within reach of cam follower lever (173) so that the latter is forced into "Start" position after rotation of the main cam.
- c) Moving the control arm (138) also releases the start lever (203) which is pulled towards the main cam by means of tension spring (204). As a result, the shut-off lever (170) is moved within the range of the dogs on the platter pinion thus driving the main cam. The change lever is also locked. To prevent malfunctions the operating switch is locked in position during the start cycle (rotation of the main cam). Just before the main cam reaches neutral position (at the end of the change cycle) the start lever (203) is pushed clear by the main cam. As a result, the operating switch and change lever are returned to their original positions. After fitment and each time after transport the unit should be started once with tonearm secured on its rest. This will automatically readjust the shut-off lever which may have shifted out of position.

Manual Start

The pawl (185) coupled to control arm (163) engages behind the square end attached to the chassis when the tonearm is moved inwards by hand and retains the control arm in this position.

The power switch is operated by the shut-off lever (165) coupled to the control arm and thus the motor and platter starts to rotate. After reaching the run-out groove of the record return of the tonearm and shut-off of the unit take place automatically.

If, on the other hand, the tonearm is lifted off the record before playing is completed and is moved onto the rest by hand, the pin of the segment (258) disengages the pawl (185) so that the control arm is returned to its starting position. As a result, the power switch shuts off the power supply.

Short Circuiter

To prevent disturbing noises during automatic operation of the tonearm the unit is fitted with a short circuiter. Control of the switch springs for both channels is effected by the camwheel. With the unit in neutral state the short circuit of the pick-up leads is eliminated.

Continuous Play

Continuous automatic repeat is operated by turning knob (46) to "∞" position. By turning the knob (46) the changeover piece (233) is actuated thus moving the change lever (189) and forcing the cam follower lever (173) to the START position.

After playing a record the tonearm is moved back and set down on the run-in groove of the record. The tonearm will repeat the record until switched back to the single-play mode (46) turned to "1" position) or until the operating lever (45) is turned to "STOP".

Fig. 17

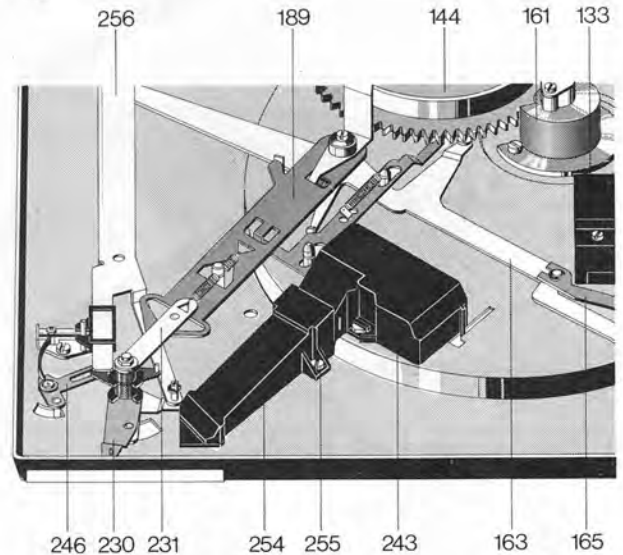

Fig. 18 Short Circuiter

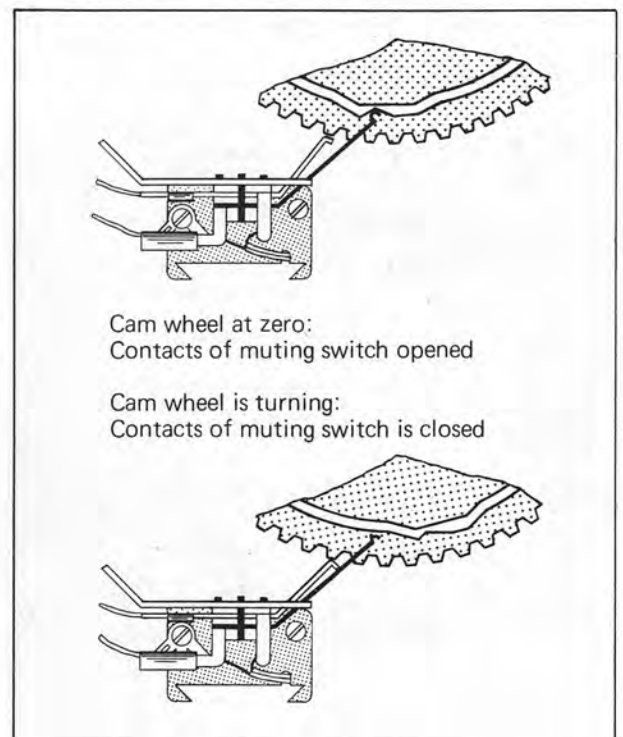

Fig. 19 Initiating shut-off function

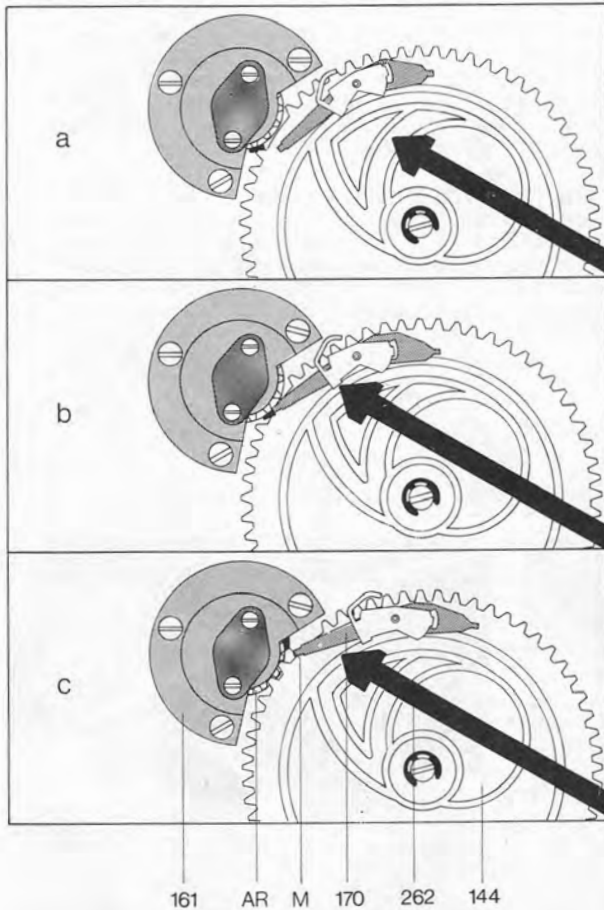

Fig. 20

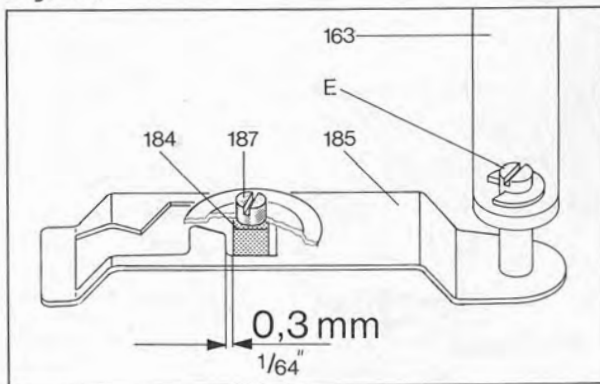
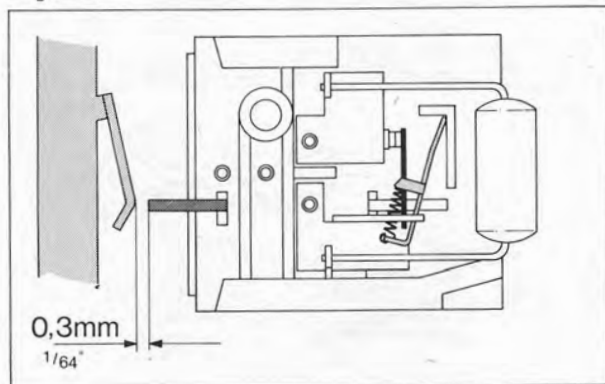

Fig. 21



Stopping

When control lever (55) is set to "stop" position the start lever (203) which is pulled towards the cam by means of tension (204), is freed. As a result, the shut-off lever (170) is moved into the range of dogs on the platter pinion thus driving the main cam. The cam follower lever (173) remains in its stop position.

Shut-off

The functions of shut-off and stop are determined by the position of the deflection lever (173). The deflection lever (173) is moved out of stop position during starting by the main lever (154) with long end of deflection lever towards camwheel center.

Initiation of shut-off after playing the record is brought about by the dog (M) of the flywheel rotor pinion (AR) and the shut-off lever (170).

The shut-off lever (122) is guided onto the dog by the movement of the tonearm when playing the record with the aid of the shut-off bar (262) proportionate to the groove lead. The eccentrically-mounted dog forces the shut-off lever (170) back with each revolution as long as the advance of the tonearm only amounts to the width of 1 groove (Fig. 19 a).

Only the run-out groove with its increased lead guides the shut-off lever (170) onto the dog at a higher rate so that the shut-off lever is picked up and moved along (Fig. 19 b).

As a result, cam (144) is moved out of its neutral position into engagement with the pinion of the platter (Fig. 19 c).

The main lever (154) guides the tonearm back and initiates lowering the tonearm on the rest.

When main cam (144) returns to zero position the pin of shift arm (163) is able to move into the recess on the main cam, operate power switch

Defect

Platter remains stationary after automatic set-down of tonearm on record.

Cause

- Shift arm (163) not locked by pawl (185).
- Power switch has interrupted power supply (has switched off)

Remedy

- Turn eccentric pin (E) on the pawl (Fig. 20)
- Adjust shut-off lever (165) (Overrun of 0.3 mm between switch slide and shift/arm).

Defect

After adjustment of the tonearm set-down point for 30 cm records the set-down point for 17.5 cm records is incorrect.

Cause

Eccentric pin (E) of contact piece (230) out of adjustment.

Remedy

Adjust tonearm set-down point by turning eccentric pin (E).

Fig. 22

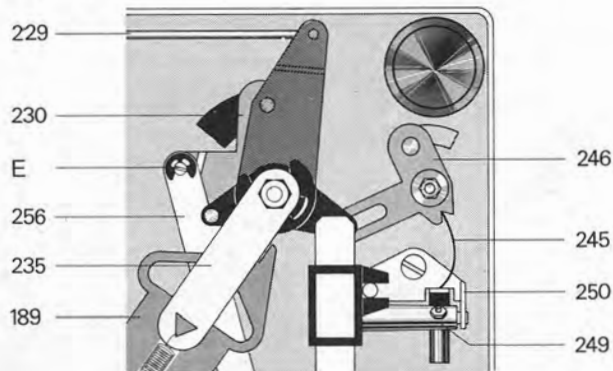
**Defect**

Horizontal tonearm movement shows resistance during set-down.

Cause

Adjustment sleeve or set screw out of adjustment.

Remedy

Rotate cam (144) from its neutral position until main lever (154) lifts the tonearm completely. Turn adjusting sleeve (211) so that the bottom edge of the cartridge head is 3 mm above the top edge of the tonearm rest, the tonearm being unlocked. Then, turn set screw (62) so that there is a play of approximately 0.1 mm between stud and contact face of tonearm (measured at tonearm head approx. 0.5 mm). (Fig. 23).

Fig. 23

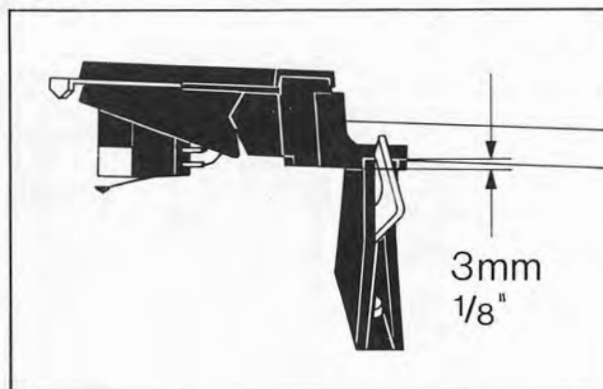
**Defect**

Tonearm moves with tracking force and anti-skating scale in 0 position
 a) outwards
 b) inwards

Cause

- a) Anti-skating device out of adjustment
- b) Excessively tight tonearm leads produce a torque

Remedy

- a) Adjust skating lever so that skating spring acts exactly at the tonearm pivot
- b) Loosen tonearm leads.

During automatic operation of tonearm disturbing noises are perceptible.

Short circuiter out of adjustment. The distances between the slide springs and the short circuit strips on the short circuiter are excessive.

By bending the short circuiter strips. Adjustment is correct when, with the camwheel in neutral position, the distance between the slide springs and the short circuit strips on the short circuiter is approximately 0.5 mm. Spray contact springs with preservative (e.g. Kontakt 61) and check adjustment of short circuit strips.

No reproduction. The short circuit of the pick-up leads is no longer being eliminated.

Distance between the slide springs and the short circuit strips on the short circuiter is absent or insufficient.

By adjusting the short circuit strips. Adjustment is correct when, with the camwheel in neutral position, the distance between the slide springs and the short circuit strips on the short circuiter is approximately 0.5 mm.

Motor does not shut off when tonearm sets down on rest.

Suppression capacitor (in power switch) is defective (short circuit).

Replace suppression capacitor in power switch with new component.

Acoustic feedback

- a) Chassis components (e.g. also connecting leads) are rubbing on outout.
- b) Connecting leads are too tight.

- a) Line up cutout according to instructions supplied with unit. Move leads.
- b) Slacken or lengthen cable

Replacement parts

Pos.	Part.-No.	Description	Quantity
1	220 213	Centering piece	1
2	232 435	Washer	1
3	234 425	Platter mat compl.	1
4	234 426	Platter compl. with mat	1
5	210 472	Machine screw AM 3 x 4	1
6	234 428	Support assembly	1
7	232 086	Tension spring	1
8	232 087	Tension spring	1
9	234 430	Locking bar compl.	1
10	232 095	Adjustment knob	1
11	232 078	Bearing bush	1
12	230 958	Speed selector	1
13	234 431	Speed control blind	1
14	214 210	Shipping screw compl.	3
15	210 624	Washer 4.3/7/0.3 ST	6
16	200 718	Compression spring	3
17	210 624	Washer 4.3/7/0.3 ST	6
18	201 632	Rubber washer	3
19	200 713	Washer	3
20	200 712	Spring cup	3
21	200 711	Lock washer	3
22	214 047	Special screw	3
23	230 529	Threaded piece	4
24	232 842	Compression spring (Motor side rear)	1
	236 017	Compression spring (Motor side front)	1
	232 843	Compression spring (Tonearm side)	2
25	200 723	Rubber damping block	4
26	200 722	Steel cup	4
27	234 432	Spring mount compl. (Motor side rear)	1
	236 401	Spring mount compl. (Motor side front)	1
	234 433	Spring mount compl. (Tonearm side)	2
28	227 535	Handle	1
29	210 182	Bowed lockwasher 4.2/8	1
30	210 630	Washer 4.2/8/0.5 ST	1
31	210 197	"C"clip 4/0.8	1
32	215 430	TK 14 cartridge mount	1
33	234 434	Flywheel rotor assembly	1
34	234 435	Flat belt	1
35	227 589	Lock nut	1
36	221 486	Grub screw	1
37	234 436	Frame compl.	1
38	210 366	Hex nut BM 4	2
39	231 992	Contact plate compl.	1
40	234 438	Tonearm head compl.	1
41	227 600	Lever compl.	1
42	210 353	Hex nut BM 2	2
43	232 124	Dress plate	1
44	234 440	Chassis compl.	1
45	232 626	Control lever	1
46	232 623	Knob (Continous play)	1
47	234 441	Start/Stop blind	1
48	231 378	Frame for cover prism	1
49	231 377	Cover prism	1
50	234 442	Tonearm compl.	1
51	225 145	Stem	1
52	234 443	Weight compl.	1
53	233 744	Yoke	1
54	234 444	Bearing compl.	1
55	227 569	Clamp bolt	1
56	230 859	Square head bolt M 2.5	1
57	230 917	Extension screw	1
58	230 916	Clamp	1
59	233 735	Spring housing compl.	1
60	216 831	Lock nut	1
61	230 063	Grub screw	1
62	217 600	Set screw	1
63	218 894	Bowed lock washer 3.2/8	1
64	229 720	Needle	1
65	229 738	Mounting screw	1
66	234 445	Bearing rack	1
67	210 587	Washer 3.2/7/1	1
68	229 062	Tonearm rest compl.	1
69	210 362	Hex nut BM 3	7
70	232 618	Locating screw for pin	1
71	232 625	Knob compl. for anti-skating	1
72	232 128	Pointer disk	2
73	234 446	Skating blind	1

Fig. 24 Exploded view, parts above chassis

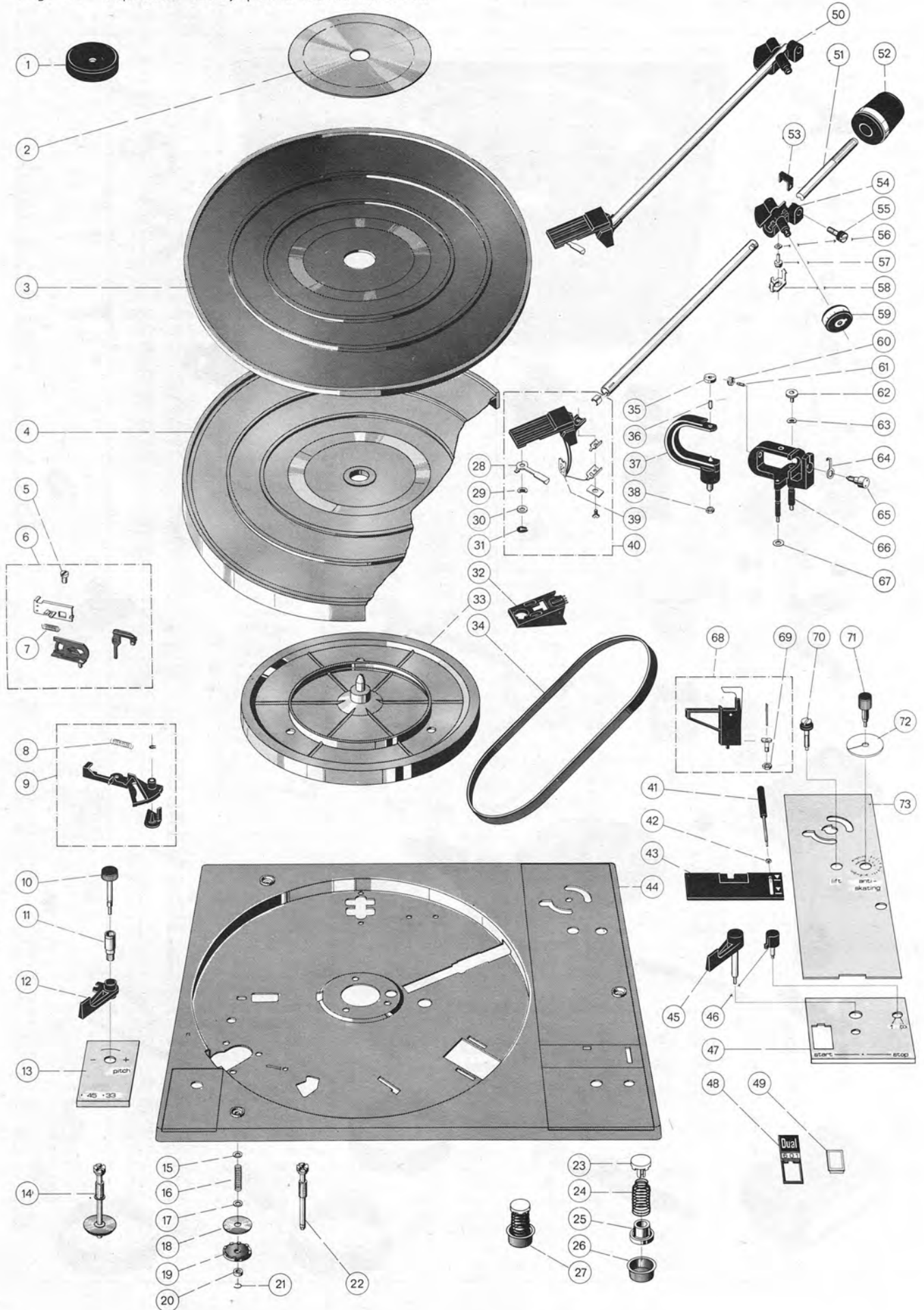
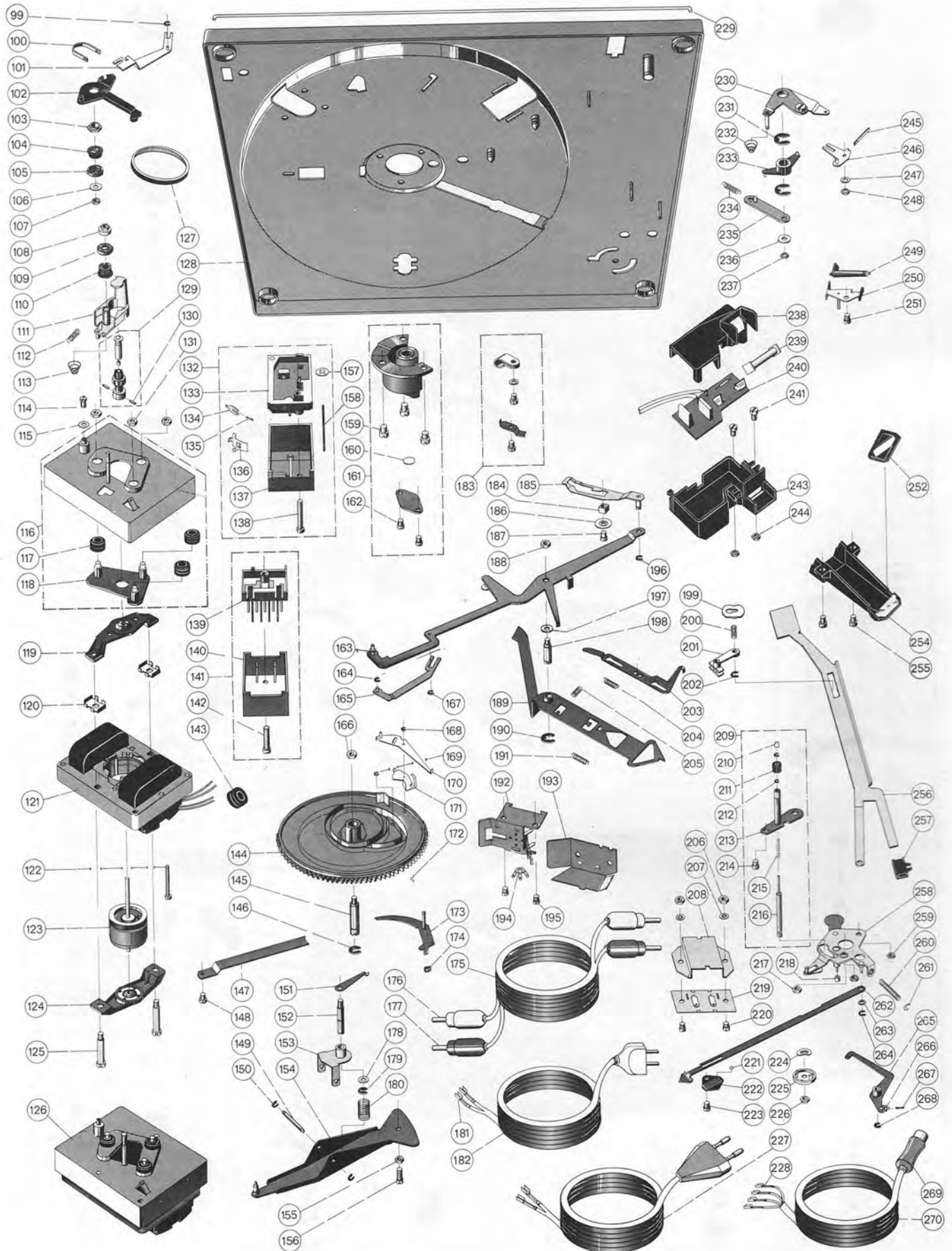

Fig. 25 Exploded view, parts below chassis



Pos.	Part.-No.	Description	Quantity
99	210 145	Lock washer 2.3	8
100	232 071	Yoke spring	1
101	232 096	Switch lever compl.	1
102	232 094	Connecting part	1
103	232 079	Joining nut	1
104	232 097	Toothed belt pulley II	1
105	232 049	Stop disk	2
106	210 607	Washer 3.2/10/0.5	1
107	210 362	Hex nut BM 3	7
108	232 099	Adjusting nut	1
109	232 049	Stop disk	2
110	232 098	Toothed belt pulley I	1
111	232 075	Counter bearing compl.	1
112	233 777	Tension spring	1
113	232 615	Compression spring	1
114	210 480	Machine screw AM 3 x 6	3
115	210 609	Washer 3.2/10/1 ST	1
116	232 856	Shield compl. with inlayer	1
117	232 841	Rubber damping block	3
118	232 840	Inlayer compl.	1
119	234 447	Top bearing compl.	1
120	232 855	Spacer	1
121	234 449	Stator 110/220 V compl.	1
122	233 815	Machine screw AM 2.5 x 18	1
123	234 450	Armature compl.	1
124	234 451	Bottom bearing bracket compl.	1
125	232 851	Centering screw	2
126	234 452	8-pole Motor SM 840 compl.	1
127	232 076	Toothed belt	1
128	234 440	Chassis compl.	1
129	234 453	Motor pulley 50 Hz compl. with conical sleeve	1
	234 454	Motor pulley 60 Hz compl. with conical sleeve	1
130	233 137	Set screw M 2.5 x 3	2
131	210 366	Hex nut BM 4	3
132	234 816	Mains switch compl.	1
	233 008	Mains switch-UL-compl. w. special capacitor	1
133	233 012	Switch plate compl.	1
	233 013	Switch plate compl. w. special capacitor	1
134	219 200	Snap spring	1
135	230 296	Tension spring	1
136	230 148	Switch slide	1
137	234 817	Cover compl.	1
	233 011	Cover-UL-compl.	1
138	210 498	Machine screw M 3 x 28	1
139	233 007	Connection plate compl.	1
140	233 006	Connection plate cover compl.	1
141	233 005	Connection plate compl. with cover	1
142	210 501	Machine screw M 3 x 35	1
143	209 939	Cable grommet	1
144	234 455	Camwheel compl.	1
145	232 548	Bearing pillar	1
146	210 148	Lock washer 5	1
147	232 074	Holding bar	1
148	210 472	Machine screw AM 3 x 4	6
149	216 864	Spindle	1
150	210 145	Lockwasher 2.3	8
151	227 079	Cable holder	1
152	232 540	Bearing bolt	1
153	232 613	Bearing support compl.	1
154	234 456	Control lever compl.	1
155	210 363	Hex nut BM 3	7
156	233 090	Machine screw AM 3 x 12	1
157	200 444	Spring washer	1
158	230 151	Slide	1
159	210 515	Machine screw M 4 x 6	3
160	232 100	Washer	1
161	234 457	Flywheel rotor bearing assy	1
162	210 475	Machine screw AM 3 x 5	5
163	232 604	Shift arm	1
164	210 144	Lock washer 1.9	1
165	232 140	Shut-off lever	1
166	210 366	Hex nut BM 4	2
167	210 145	Lock washer 2.3	8
168	210 145	Lock washer 2.3	8
169	210 142	Lock washer 1.2	1
170	232 608	Shut-off lever	1
171	232 119	Friction plate compl.	1

Pos.	Part.-No.	Description	Quantity
172	200 522	Snap spring	1
173	232 607	Cam follower lever	1
174	200 650	Rubber sleeve	1
175	226 817	Pick-up lead compl. with Cynch plug	1
176	209 425	Cynch plug white	2
177	209 426	Cynch plug black	2
178	210 658	Washer 5.1/10/1 ST	1
179	210 146	Lock washer 3.2	4
180	232 914	Compression spring	1
181	214 602	AMP connector	4
182	232 995	Power lead US compl.	1
183	231 079	Cable clips compl.	1
184	219 049	Square section	1
185	232 599	Paul compl.	1
186	229 704	Washer	1
187	227 060	Threaded bolt	1
188	210 362	Hexnut BM 3	7
189	232 612	Change lever compl.	1
190	210 147	Lock washer 4	1
191	236 286	Tension spring	1
192	236 402	Short circuiter	1
193	232 084	Shield	1
194	211 614	Soldering lug	1
195	210 472	Machine screw AM 3 x 4	1
196	210 146	Lock washer 3.2	6
197	210 586	Washer 3.2/7/0.5 ST	4
198	232 542	Grooved pin	1
199	223 146	Fuse spring	1
200	234 303	Compression spring	1
201	227 068	Bearing	1
202	210 145	Lock washer 2.3	8
203	232 109	Start lever	1
204	233 710	Tension spring	1
205	232 844	Compension spring	1
206	210 362	Hex nut BM 3	7
207	210 155	Serrated lock washer	2
208	233 089	Screen plate compl. with insulating plate	1
209	234 458	Lift tube compl.	1
210	216 844	Guide	1
211	218 318	Adjusting sleeve	1
212	210 143	Lock washer 1.5	3
213	232 614	Lift plate compl.	1
214	210 469	Machine screw AM 3 x 3	5
215	216 853	Compression spring	1
216	232 609	Lift pin	1
217	210 366	Hex nut BM 4	2
218	223 777	Guide	1
219	227 254	Cynch socket plate	1
220	210 480	Machine screw AM 3 x 6	2
221	209 357	Steel Ball 3.2	1
222	232 104	Ball bearing (bed)	1
223	210 469	Machine screw AM 3 x 3	5
224	216 867	Bowed lock washer 5.2/10	1
225	225 176	Asymmetrical plate cam	1
226	210 362	Hex nut BM 3	7
227	232 996	Power cable Europe compl.	1
228	209 436	Flat connector sleeve	4
229	232 534	Control rod	1
230	232 600	Contact piece	1
231	232 621	Lock washer 8	2
232	234 106	Conical spring	1
233	232 103	Changeover piece	1
234	233 710	Tension spring	1
235	232 603	Switch lever	1
236	210 641	Washer 4.2/10/1	1
237	210 362	Hex nut BM 3	7
238	234 459	Cover (housing top) compl.	1
239	225 321	Glow lamp	1
240	234 460	Wiring board compl.	1
C 1	225 322	Foil capacitor 68 nF/400 V/10 %	1
C 2	224 886	Foil capacitor 47 nF/250 V/20 %	1
D 1	225 247	Silicon diode BY 183/300	1
R 1	232 402	Film resistor 22 kOhm/0.25 W/5 %	1
R 2	232 401	Film resistor 12 kOhm/0.125W/5 %	1

Lubrication

All bearing and friction points of the unit are adequately lubricated at the works. Replenishment of oil and grease is only necessary after approximately 2 years of normal use of the record player as the most important bearing points (motor bearings) have sintered metal bushes.

Bearing points and friction faces should be lubricated sparingly rather than generously.

It is important that no oil or grease should come in contact with the friction faces of the flat belt, drive pulley and flywheel rotor, otherwise slip will occur.

When using different lubricants, chemical decomposition can often take place. To prevent lubrication failure we recommend using the original lubricants stated below. The following lubricants should be used for subsequent lubrication:

Fig. 26

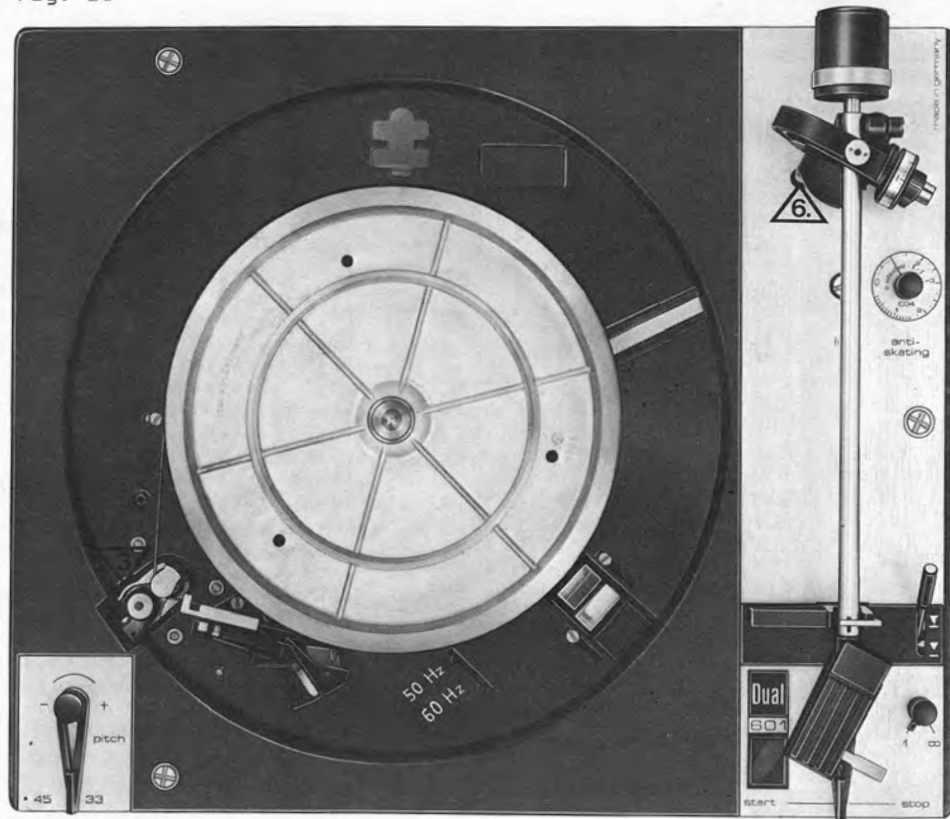







Fig. 27

-  BP Super Viscostatic 10 W/30
-  Shell Alvania No. 2
-  Isoflex PDP 40
-  Silicone oil AK 500 000
-  Molykote

