

Dual

Edition April 1979

CS 714 Q



Service Manual

Dual Gebrüder Steidinger 7742 St.Georgen/Schwarzwald

Fig. 1 TA-Anschlußschema / Audio Connection Diagram / Schema de branchement / Esquema de conexion del fono captor

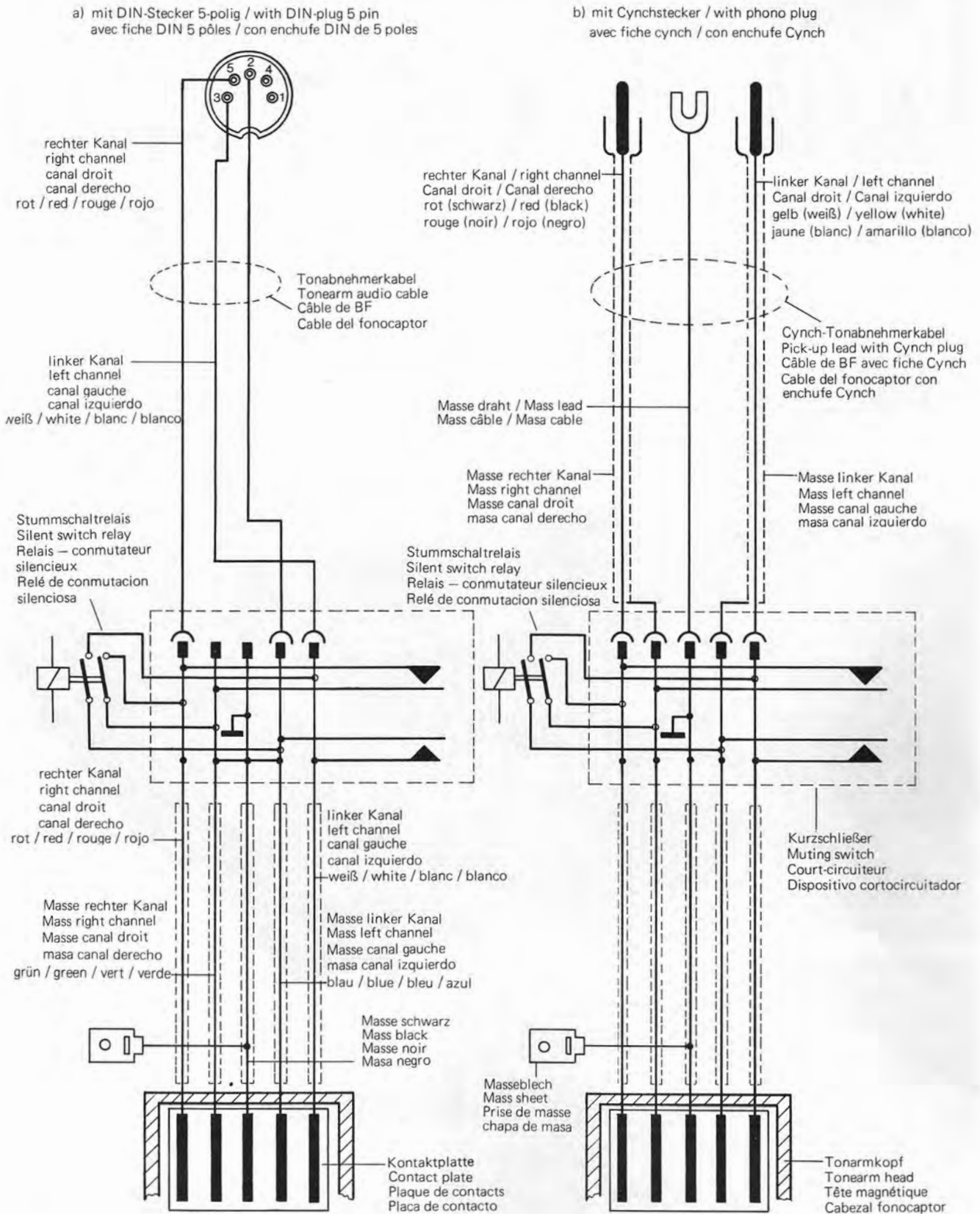

Contents

Page	
2	Tonearm connection diagram
3	Technical data
4	Block diagram
5	Direct drive system EDS 920
5	Wiring diagram
6	General
6	Fascia
6	Motor and drive
6	Replacing motor electronic system
6	Replacing motor mechanical system
6	Pitch control
6	Stroboscope
7	Tonearm and tonearm suspension
7	Fitting a 1/2" cartridge
7	Removal of tonearm from bearing frame
7	Removal of complete tonearm
8	Replacement of spring housing
8	Adjustment of tonearm suspension
8	Anti-skating control
8	Tonearm cue control
8	Adjustment point
8	Replacement of cue control plate
8	Tonearm control
9	Manual start
9	Muting switch
9	Shut-off
10	End of play shut-off
10	Adjustment points
10	Power fuse
10	Segment
10	Shut-off point
10	Power switch
10	Pull magnet "cueing"
10	Tonearm does not set down
10	Vertical tonearm movement is inhibited
10	Platter does not rotate
10	Motor does not shut-off
11 - 14	Spare parts list with exploded views
14	Lubrication instructions

Technical data

Current type	AC 50 or 60 Hz
Line voltages	110 - 125 V and 220 - 240 V
Drive	Quartz stabilized electronic direct drive system Dual EDS 920, PLL control
Power consumption	Approx. 4 W, motor during play < 50 mW
Run-up time	(until nominal speed is reached) approx. 1.8 s at 33 rpm
Platter	Non-magnetic dynamically balanced, complete rotary mass detachable approx. 1.5 kg
Platter speeds	33 and 45 rpm, electronically switchable, quartz stabilized
Pitch control	In PLL technology, quartz accurate for both speeds, separately adjustable, range of adjustment $\pm 5.5\%$
Speed check	Quartz accurate, illuminated stroboscope with automatic frequency switch-over for 33 and 45 rpm
Sensitivity of light stroboscope for 0.3 % speed deviation	20 graduations per minute
Wow and flutter	DIN < $\pm 0.025\%$ WRMS < $\pm 0.015\%$
Signal-to-noise ratio	Rumble unweighted signal-to-noise ratio > 52 dB Rumble weighted signal-to-noise ratio > 75 dB
Tonearm	Torsion-resistant "ultra-low-mass" aluminum tonearm, in gimbal 4-point suspension, tonearm balance weight with tuning anti-resonator
Effective tonearm length	221 mm
Offset angle	$26^{\circ} 4'$
Tangential track error angle	$0.16^{\circ} / \text{cm}$
Tonearm-bearing friction (related to stylus point)	Vertical < 0.07 mN (0.007 g) Horizontal < 0.15 mN (0.015 g)
Tracking force	From 0 - 20 mN (0 - 2 g) infinitely variable with 1 mN (0.1 g) Calibration in range from 2 - 15 mN (0.2 - 1.5 g)
Pick-up head	Detachable, suitable for ultra-low-mass cartridges, with long carrier plate (accessory), also suitable for cartridges with Dual shap-in mounting and for cartridges with 1/2" mounting and a weight of 2 to 9 g (including mounting hardware)
Cartridge	Adjustable overhang: 5 mm
Weight	See separate data sheet Approx. 7.8 kg

Fig. 2

BLOCKSCHALTBILD

BLOCK DIAGRAM

SCHEMA SYNOPTIQUE

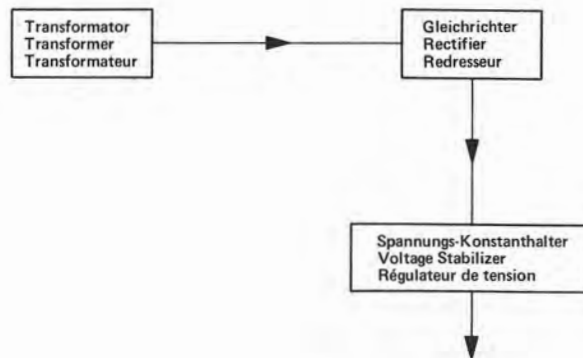
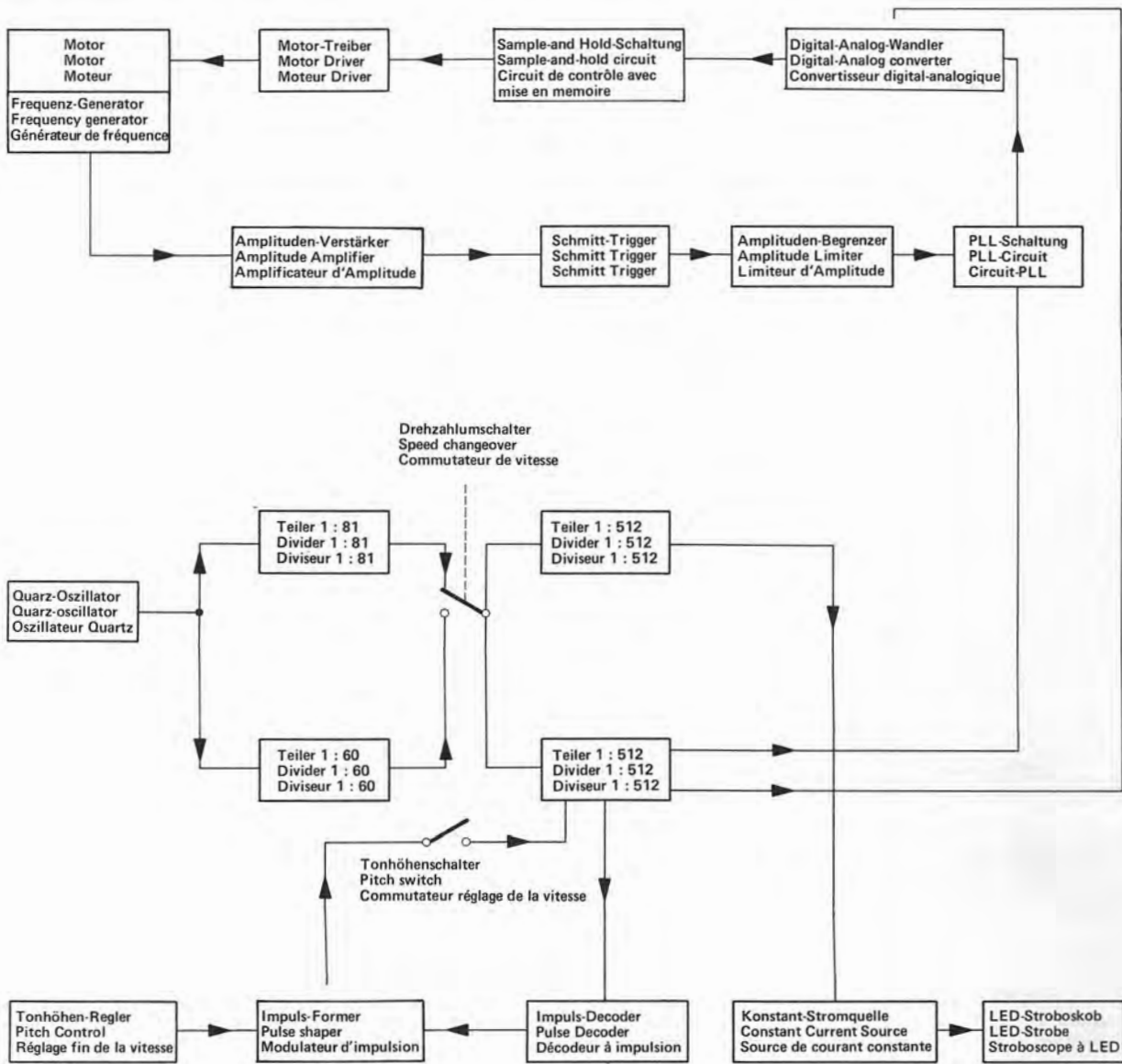

EDS 920 direct drive system

The newly developed direct drive system of the CS 714 Q turntable is a successful synthesis of our well-known motor principle and a highly sensitive electronic system which receives its accuracy from a quartz crystal. The drive motor is a DC motor with no commutator in which commutation is carried out by two Hall generators which detect the position of the rotor equipped with an 8-pole ring magnet and which also actuate the corresponding windings of the rigid flat coils. The synchronously rotating magnetic return circuit plate and the ring magnet enclose with a small air gap the non-ferrous coil arrangement so that, on the one hand, the drive system displays an extremely uniform running characteristic without pole sensitivity and which displays, on the other hand, a high torque in spite of the economical energy supply. After the nominal speed has been attained, the energy supply required for maintenance of rotation is less than 50 mW.

Description of function

At a motor speed of $33 \frac{1}{3}$ rpm, the 200-pole frequency generator rigidly coupled to the motor delivers a frequency of 111 Hz which is amplified in the input amplifier and prepared in the cam form. This signal is applied as an actual value to the PLL circuit. An oscillation frequency of 4.608 MHz, which is controlled by a highly precise quartz crystal, is generated in the quartz oscillator. The actual reference frequency – that is to say, the set value – is derived from the oscillator frequency by a multi-stage divider. In the PLL circuit, the actual value and set value are compared with one another as regards amount and phase. In the case of the slightest deviation, a control pulse is applied to the digital/analog converter which obtains from this an analog control signal which is converted into a current alteration in the subsequently connected motor control circuit. In the drive motor, this current alteration causes spontaneous stabilization of the minimal speed deviation.

Fig. 3

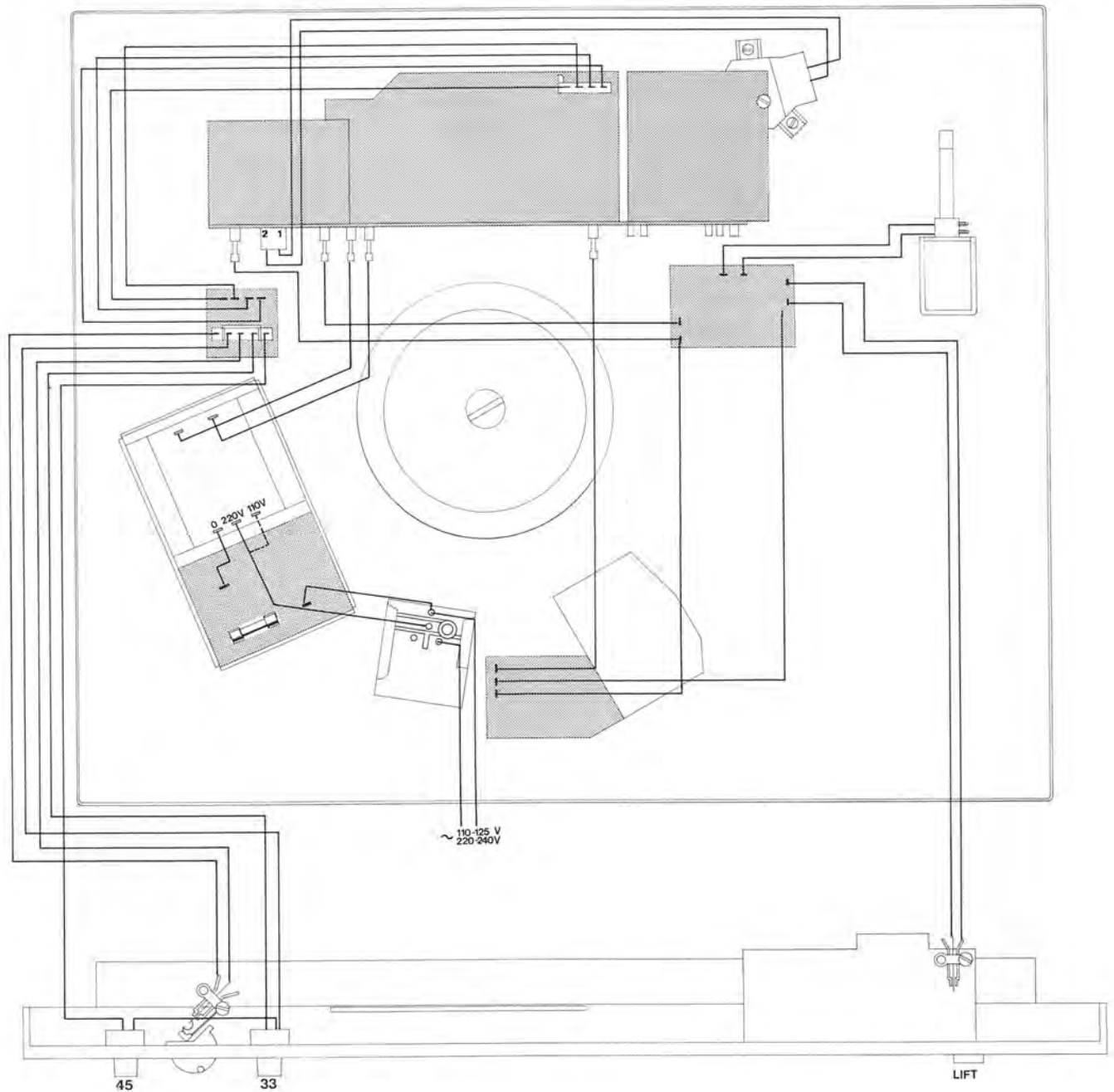

The set value necessary for the 45 rpm speed is generated in the voltage divider by alteration of the divider ratio. For pitch control, a continuously variable control signal, with which the control loop is fed, is obtained by means of a complicated division process.

Thus the complete control range, like the nominal speeds, is coupled in a locked-phase relation to the quartz oscillator. The speed accuracy in the pitch range is practically the same as in the case of nominal speed. The speed deviation preselected with both pitch controls is maintained even if the pitch switch is operated or if the unit is switched off.

General

The listed item numbers refer to the following spare parts lists and exploded views.

The cover can be easily withdrawn from the hinged splice pieces. To remove the turntable, remove both fillister head screws (98) and the discs (86) with which the mounting plate (197) is screwed down. The turntable can be lifted out of the bracket (12) after disengaging the three transport locking screws.

Now detach the following plug connections:

- 1) Both single-pole plugs (122) on power switch (106).
- 2) The 4-pole plug (160) on the solenoid protective circuit (185).
- 3) The 5-pole female multi-point connector (158) at the display unit (35).
- 4) The 5-pole female multi-point connector (185) at the distributor board (24).

Fascia

To dismantle the fascia, remove both attachment screws (21) with which the display unit is mounted on the bracket base.

The top of the plate (17) is attached with 3 fillister head screws (98) and three washers (86) and the bottom is attached with three cheesehead screws (50).

Fig. 4

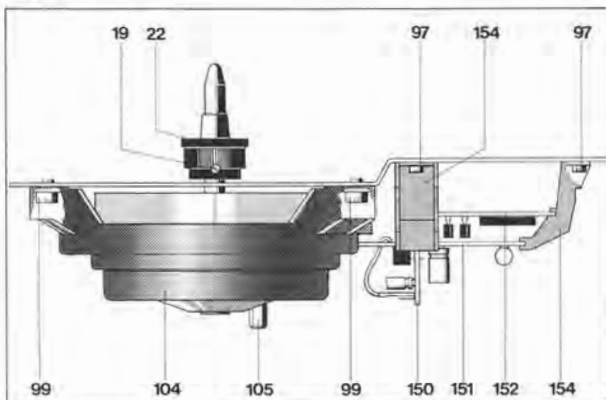

Motor and drive

Special tools and measuring instruments are necessary for repair of the Dual EDS 920. Therefore, work on the motor or the motor electronic system should only be carried out by an authorized Dual service station.

Replacement of the motor electronic system, complete

The individual modules (151/152/153) are plugged into the main board. In addition, they are held by means of supports (154). Moreover, module 1 is also secured with the fixing screw (159). When replacing the complete motor electronic system, proceed as follows:

- 1) Remove the fillister head screws (97) and the four supports (154).
- 2) Remove fixing screw (159) (module 1).
- 3) Detach the plug connections for the connection cable – refer to wiring diagram Fig. 3.
- 4) Detach the motor electronic system completely from the mechanical system of the motor and replace it.

Replacement of the mechanical system of the motor

- 1) Release both threaded pins (19) and withdraw plate cone (22).
- 2) Remove the complete motor electronic system – see above. The plug connections of the connecting cable need not be removed.
- 3) Remove both fillister head screws (99) and the cog (105).
- 4) Withdraw the mechanical system of the motor and replace it.

Fig. 5

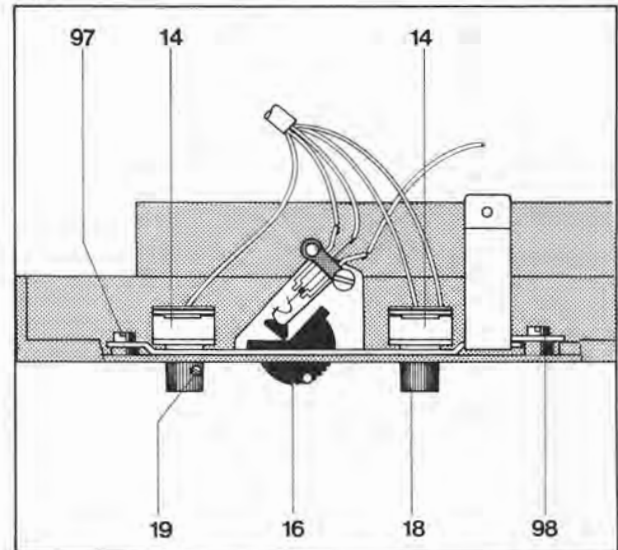

Pitch control

With the pitch control, each of the two rated speeds, 33 1/3 and 45 rpm, can be varied by ± 5.5 %. With the seesaw switch (16) at "ON" position, each nominal speed can be altered by means of a separate potentiometer (14). At the same time, the optoelectronic display scale (35) indicates the percentage deviation from the nominal speed.

Independently of the potentiometer setting (14), the speed corresponds with quartz precision to the respectively switched nominal speed, if the seesaw switch (16) is in "OFF" position.

Stroboscope

The stroboscope markings on the turntable edge are flashed from the diode plate (148) by means of quartz accurate frequency. The display is independent of power frequency and does not require additional stroboscope markings for different speeds and line frequencies.

When the stroboscope markings seem to be stationary both nominal speeds (33 1/3 and 45 rpm) are accurately adjusted. If the markings seem to run ahead the speed is higher. If the markings seem to run back the speed is lower than the nominal speed.

By means of the speed of the apparently "wandering" markings the speed selected with potentiometer (14) can be determined at high speeds: 1 graduation/sec. = 0.9 % deviation. After releasing the fixing screw (159) and removing both fillister head cap screws (96) the stroboscope housing can be removed (149). After removing the retainer piece (147) the three LED's (148) can be replaced.

Tonearm and tonearm suspension

The light, torsion-resistant all-metal tonearm is twingimbal mounted. Suspension is by means of four hardened and precision polished steel points which rest in precision ball bearings. The tonearm bearing friction is thus reduced to a minimum.

Bearing friction vertical	0.07 mN (0.007 g)
Bearing friction horizontal	0.15 mN (0.015 g)

as related to stylus point.

This ensures extremely favorable pick-up conditions. Before setting the tracking force corresponding to the built-in pick-up cartridge the tonearm is balanced at 0 position of the tracking force scale. Coarse adjustment is carried out by moving the weight with stem (60) subsequent fine adjustment by turning the front knurled ring on the weight.

The balance weight is designed so that pick-up cartridges having a dead weight (including fitting material) of 2 – 9 g can be balanced. The tracking force is produced by tensioning the coil spring fitted in the spring housing (74). The rotary knob (69) is provided with a scale which permits accurate adjustment of the tracking force in the range from 0 – 20 mN (0 - 2 p) by means of the marking dots.

Fitting a 1/2" cartridge

The description of retrofit for fitting a 1/2" cartridge (replacement of carrier plate etc.) should be taken from the operating instructions.

Fig. 6

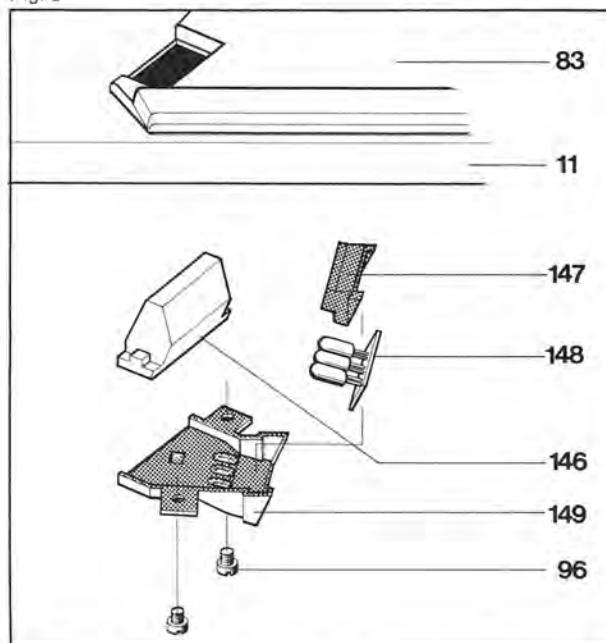

Removal of tonearm from bearing frame

- 1) Secure unit in repair jig. Remove weight (60). Unscrew tensioning screw (52). Set rotary knob (63) to 0.
- 2) Turn unit upside down. Remove hexagon nut (34) and screening plate (119). Unsolder tonearm leads on muting switch (120).
- 3) Unscrew tensioning screw (70). Remove rotary knob (69), disc (68) and indicator (67).
- 4) Loosen locking nut (61) and unscrew threaded pin (65).
- 5) Remove tonearm (30) with bearing (71).

Assembly takes place in reverse order.

Removal of tonearm complete with tonearm mounting

Proceed as follows:

1. Secure unit in repair jig. Set rotary knob (69) to 0 position. Lock tonearm (30). Remove weight (60).
2. Bring unit into its highest position, remove hexagon nut (69) and screening plate (119). Unsolder tonearm leads on short circuiter (120).
3. Remove securing disc (89), disc (175) as well as bearing (174). Swivel transition plate (173) to short circuiter (120).

Fig. 7

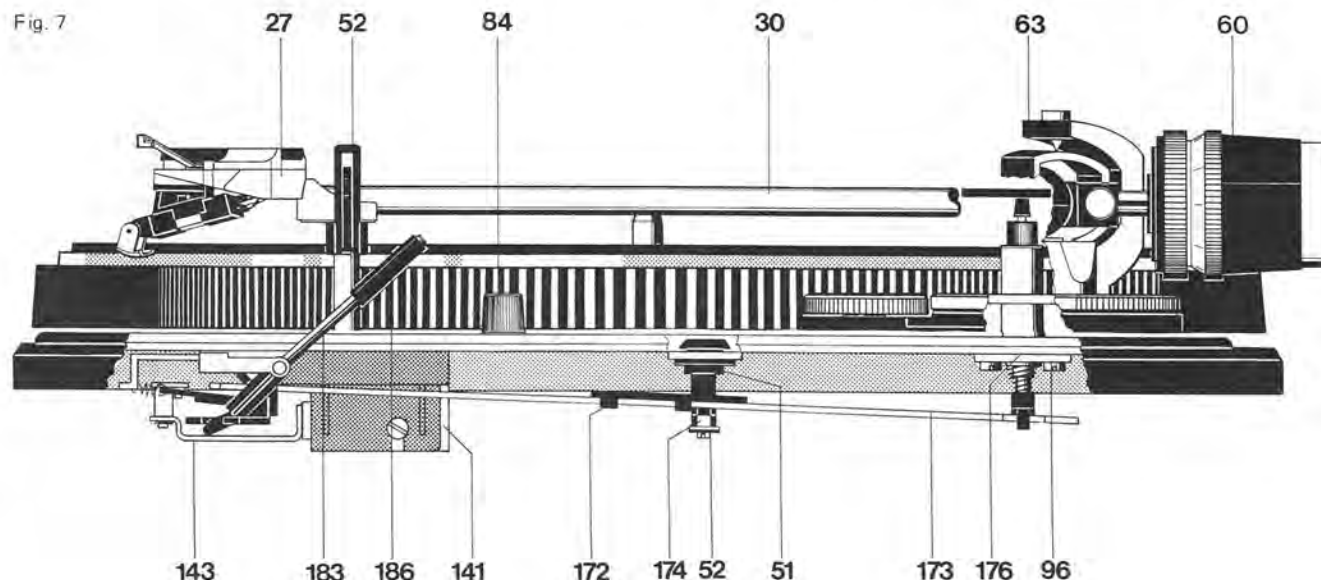

4. Disengage tension spring (128), fastening disc (90) and remove skating lever.
5. Remove hexagon nuts (94) and segment (124).
6. Hold tonearm (30). Remove hexagon nut (95); remove tonearm complete with tonearm mounting.

When installing the tonearm proceed in reverse order.

Replacing spring housing

Remove tonearm (30) from bearing frame (66) as described above. During fitment, ensure that the spiral spring engages in the cut-out of the bearing (71). Fit tonearm (30) again. Set bearing play as described below using threaded pin (65) and lock nut (61).

Adjusting the tonearm bearing

First balance tonearm exactly. Both bearings must have slight, just perceptible play. The horizontal tonearm bearing is correctly adjusted when at anti-skating setting "0.5" and being touched, it slides in without resistance. The vertical tonearm bearing is correctly adjusted when it swings in after being touched. Play of the horizontal tonearm bearing should be adjusted with threaded pin (62), play of the vertical tonearm bearing with threaded pin (65).

Anti-skating device

Adjustment of the anti-skating force is carried out by turning the knurled ring on the cover. According to adjustment the asymmetrical cam disc guides the skating lever (134) out of the tonearm pivot point. The anti-skating force is transmitted to the segment (124) by means of tension spring (136) and so to the tonearm. Optimum adjustment is carried out at the works for styli with a tip radius of $15 \mu\text{m}$ (conical), and $5/6 \times 18/22 \mu\text{m}$ (elliptical) as well as for CD 4 cartridges.

Any alteration can only be carried out with the aid of a Dual skate-0-meter and a test record and should only be done by a Dual authorized service station.

Cue control

By moving lever (187) forward (▼) lift cam (188) rotates. The side bar (168) connected to it transmits this movement to the lift pin which then raises the tonearm.

As a result the tonearm can be lifted off and set down on a record at any desired point outside the shut-off range.

The side bar (187) is released by moving the cue control lever back (▲). As a result of the action of the compression spring the lift pin is returned to neutral position and thus lowers the tonearm. Lowering of the tonearm is damped by the silicone oil in the lift tube.

Height of the stylus above the record can be varied by the pre-tension of the compression spring of the lift plate (176). According to operation of the adjusting ring (82) in "◀" the lowering speed is reduced, in position "◀◀" it is increased.

Adjustment point

The lift height is varied by turning the adjustment sleeve (187). The distance between record and stylus should be approximately 5 mm.

Fig. 8

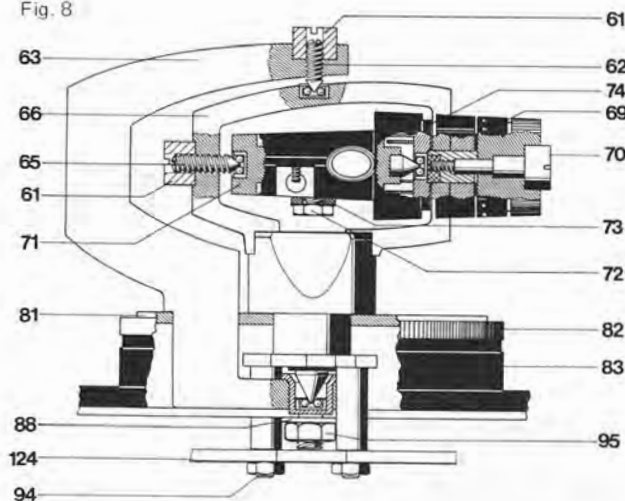
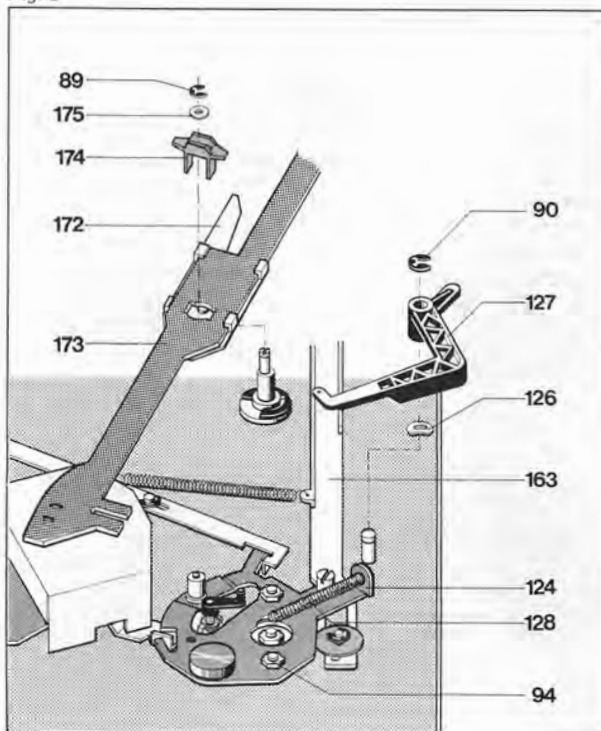

Fig. 9



Replacement of the cue control plate

Replace cue control plate complete (187) as follows:

1. Fix unit on repair jig and lock tonearm. Turn unit upside down.
2. Remove fastening disc (89) and disc (175) as well as bearing (174). Lift adjusting bar (173) and swivel to short circuiter (120).
3. Remove both fillister head cap screws (96). Remove cue control plate (188).
4. Remove hexagon nuts (94) and segment (124).

When fitting proceed in reverse order. It should, however, be ensured that the pressure piece of the cue control plate (188) engages correctly in adjusting ring (82). (Varying the lowering speed).

Tonearm set down aid

Operation of rotary knob (84) in position "V" sets the cut-outs in the adjusting bar (173) in the range of the spring bolt (F) of segment (124). During slow swivel of the tonearm – tonearm lift in position " " – the spring bolt (F) engages in the cut-outs of the positioning bar (172). By this means with records of 30 cm and 17 cm diameter exact set down point of the stylus is indicated.

To permit set down in trip range of the engagement point of the individual set down points, the tonearm set down aid can be switched off. Rotary knob (84) in position "–".

Adjustment points

- Balance tonearm (48) exactly. Rotary knob (68) in position "V". Allow tonearm to engage. Between positioning bar (173) and the guide bush of spring bolt (F) a clearance of 0.2 mm should be present. Adjustment by means of turning the screw pin (52). The engagement force should be approximately 10 – 20 p.
- The tonearm set down point can be corrected by turning the adjusting screw (51). Adjustment is effective for 17 cm as well as 30 cm records.

Muting switch

To prevent disturbing noises the unit is fitted with a muting switch. Control of the switch springs for both channels is effected by the cam wheel. With the unit in neutral state the short circuit of the pick-up leads is eliminated.

Adjustment point

In neutral position of the cam wheel the contact distance between contact springs (F) and muting switch strips (L) should be approximately 0.5 mm. If necessary bend muting switch strips. Spray contact spring with suitable cleaning aid.

Starting and switch-off

By swivelling in of the tonearm (30) the segment (124) is turned. By this means the power switch (106) is operated and the motor (104) as well as the platter (3) is rotated. Switch-off after play of a record is initiated by follower (M) of the platter (3) and the switch-off lever (A).

The switch-off bar (137) is guided into switch-off range by the segment (124).

The switch-off lever (A) is guided the switch-off range (record ϕ 116 to 122 mm) from the switch-off bar (137) to the follower (Fig. 15 a).

The follower (M) attaches the switch-off lever (A). The cam wheel (25) reaches by this means into engagement with the pinion of the platter. The tonearm (30) is lifted off and brought to the support by means of return bar (163). By this means the power switch (106) is actuated which switches off the unit.

Adjustment points

Power fuse

After removal of both attachment screws and removal of power section cover the fuse (102) on the power plate (101) can be replaced.

Fig. 10

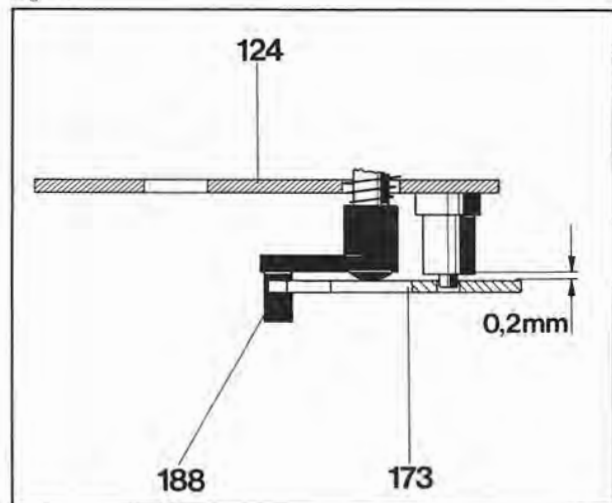

Fig. 11

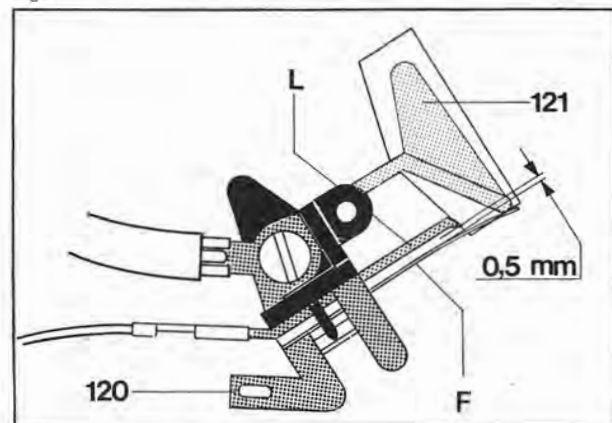
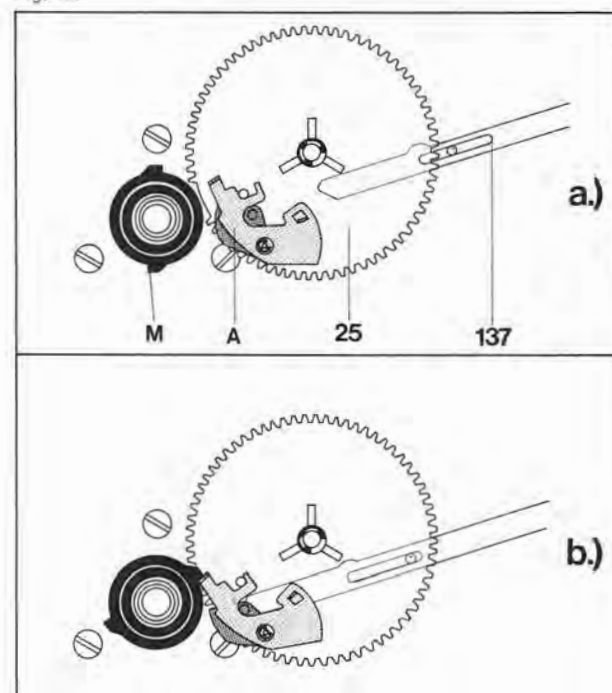

Fig. 12



Adjustment points

Segment

- a) During fastening of the segment (124) it should be ensured that a tolerance of 0.5 mm is present between segment (124) and the switch lever (36).

Shut-off point

The shut-off point can be altered by means of the eccentric (E) on the segment (124) (Fig. 13). (Shut-off range for records ϕ 116 to 122 mm).

Power switch

Move in tonearm (30). The slide (109) of the power switch (106) should have a play of 0.2 to 0.5 mm. Carry out adjustment by bending the switch lever (36).

Pull magnet "lift"

The travel of the pull magnet can be altered with the eccentric (E₂). During operation of the pull magnet up to the stop the lever (183) should still just evidence perceptible play (min. 0.1 mm).

Fig. 13

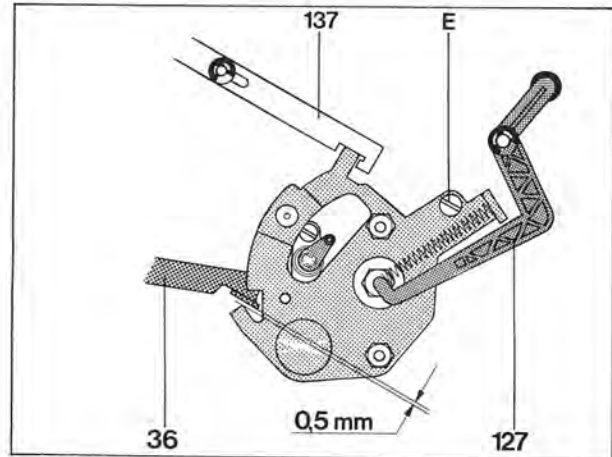

Fig. 14

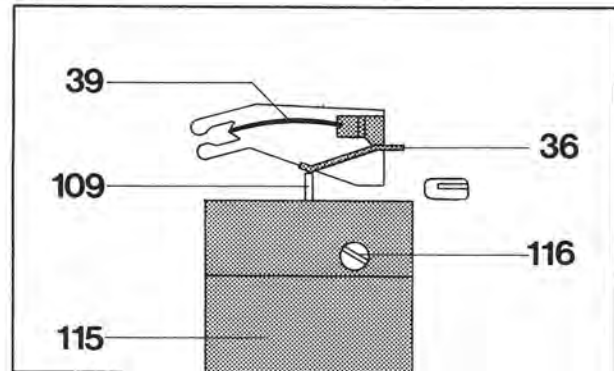

Fig. 15

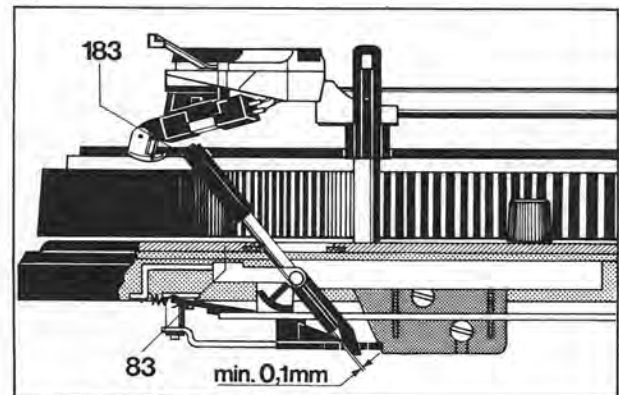
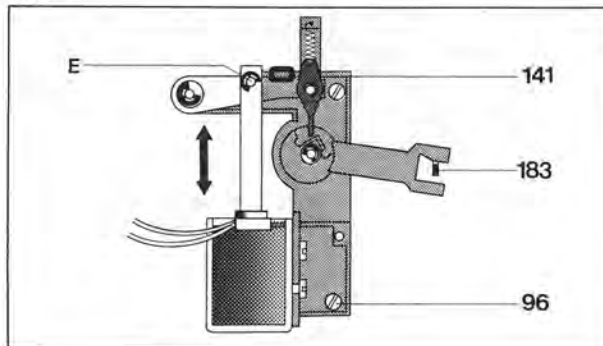

Fig. 16



Defect

Tonearm does not set down or sets down too quickly after operating cue control lever (183).

Vertical tonearm movement is inhibited

Platter does not run after connection of the unit and moving into position of the tonearm

Motor does not shut off when tonearm sets down on rest

Cause

Damping excessive or too low as a result of contamination of the silicone oil

Lift pin jammed in guide tube

Power fuse (102) is defective

Suppression capacitor (110) in power switch is defective (short-circuit).

Remedy

Dismantle lift plate (188); described on page 8. Remove adjusting sleeve (187). With straw lever pin, clean lift tube and lift pin. Grease lift pin uniformly with "Wacker Silicone oil AK 300 000". Reassemble components

See above, if necessary renew lift plate (188).

Renew power fuse (102).

Renew suppression capacitor in power switch.

Replacement parts

Pos.	Part.-No.	Qty	Description	Pos.	Part.-No.	Qty	Description
1	220 213	1	Centering disc	67	246 874	1	Indicator
2	249 308	1	Turntable mat cpl.	68	247 325	1	Securing disc, threaded 5.2/10
3	249 309	1	Turntable cpl.	69	247 136	1	Rotary knob
4	245 695	1	Rotary knob	70	246 882	1	Tension screw, long
5	249 310	1	Speed cover	71	249 654	1	Bearing cpl.
6	234 432	2	Spring suspension cpl.	72	244 103	1	Hexagon screw 2.9 x 6.5
	234 433	1	Spring suspension cpl. (tonearm side front)	73	244 244	1	Disc 3.05/6/1.5
	237 226	1	Spring suspension cpl. (tonearm side rear)	74	249 655	1	Spring housing
7	230 529	4	Threaded piece	75	246 883	1	Tensioning screw
8	232 842	2	Compression spring	78	242 141	1	Contact lever
	232 843	1	Compression spring (tonearm side front)	79	242 143	1	Tensioning spring
	236 710	1	Compression spring (tonearm side rear)	80	234 838	1	Adjustment wheel
9	200 723	4	Rubber damper	81	247 024	1	Disc
10	200 722	4	Steel cup	82	247 023	1	Adjusting ring
11	249 311	1	Mounting plate cpl.	83	249 656	1	Cover cpl.
12	249 312	1	Bracket CK 70, walnut	84	245 685	1	Rotary knob
	249 314	1	Bracket CK 70, agate black	85	210 155	2	Toothed disc A 3.2
	249 315	1	Cover CH 16	86	210 586	9	Disc 3.2
13	244 889	1	Microswitch	87	200 444	12	Spring disc
14	247 782	2	Potentiometer	88	210 644	1	Disc 4.2/12/1.5
15	237 782	2	Potentiometer nut	89	210 145	5	Securing disc 2.3
16	246 871	1	Seesaw switch	90	210 146	7	Securing disc 3.2
	249 477	1	Seesaw switch (for metallic plate)	91	210 147	1	Securing disc 4
17a	249 317	1	Plate cpl., agate black	92	210 151	1	Securing disc 7
17b	260 975	1	Plate carrier	93	210 353	1	Hexagon nut M 2
17c	260 980	1	Bracket plate, metallic silver	94	210 362	7	Hexagon nut M 3
	260 981	1	Bracket plate, metallic brown	95	210 366	1	Hexagon nut M 4
17d	249 476	2	Ring	96	210 469	8	Fillister head cap screw AM 3 x 3
17e	260 982	1	Name plate	97	210 472	5	Fillister head cap screw AM 3 x 4
17f	249 473	1	Ring	98	210 486	4	Fillister head cap screw AM 3 x 8
18	247 045	2	Rotary knob	99	210 516	2	Fillister head cap screw AM 4 x 8
	249 339	2	Rotary knob (for metallic plate)	100	210 517	4	Fillister head cap screw M 3 x 30
19	242 191	4	Threaded pin M 3 x 3	101	246 133	1	Power plate cpl.
22	242 192	1	Conical plate	102	209 719	1	Fuse insert T 0.125/250 V
23	245 663	1	Rotary switch cpl.	103	249 657	1	Power transformer cpl.
24	246 237	1	Distributor plate cpl.	104	249 658	1	Motor mechanical system cpl.
25	244 464	1	Cam wheel cpl.	105	247 062	1	Cog
26	249 319	1	Carrier plate cpl.	106	242 580	1	Power switch cpl.
	249 320	1	Carrier plate cpl. 1/2" cpl.	108	233 012	1	Switch plate cpl.
27	249 318	1	Tonearm head cpl.	109	236 335	1	Slide
28	237 223	1	Contact plate cpl.	110	241 883	1	Capacitor 10 µF
30	249 322	1	Tonearm cpl.	111	242 822	1	HF throttle 47 µH
31	249 323	1	Mounting TK 26	112	230 148	1	Switching angle
34	234 759	1	Screw pin	113	219 200	1	Snap action spring
35	210 630	1	Disc 4.2/8/0.5	114	239 732	1	Tension spring
36	242 142	1	Switch lever	115	242 095	1	Cover cpl.
37	242 145	1	Silicone tube	116	210 498	1	Fillister head cap screw M 3 x 28
38	210 586	1	Disc 3.2	117	249 685	1	Muting switch cpl.
39	242 144	1	Plate spring	118	247 515	1	Threaded pin
40	236 843	2	Hinge cpl.	119	247 516	1	Screening plate
41	210 287	2	Fillister head screw B 2.9 x 13	120	242 612	1	Muting switch cpl.
42	231 767	2	Securing plate	121	242 182	1	Contact arm
43	210 686	1	Disc 5.3/10/1	124	249 686	1	Segment
44	231 654	1	Hinge axle	125	201 184	1	Adjusting disc
45	234 145	2	Compression spring	126	221 430	1	Securing disc, threaded
46	231 656	2	Hinge cam	127	244 331	1	Skating lever
47	231 657	1	Hinge plate	128	218 591	1	Tension spring
48	234 837	1	Disc 6.2/10/1	129	245 688	1	Transport lever
49	234 837	1	Adjusting nut	130	210 607	1	Disc 3.2/10/0.5
50	247 353	2	Fillister head screw B 2.9 x 13	131	242 175	1	Screw bolt
51	234 781	1	Adjusting screw	132	210 182	1	Securing disc, threaded 4.2/8
52	234 818	1	Stud bolt	133	233 710	1	Tension spring
53	249 324	1	Support cpl.	134	228 113	1	Disc 4.2/8/1
54	239 414	3	Transport lock cpl.	135	242 187	1	Switch element
55	247 021	1	Switch plate	136	242 195	1	Switch piece
	260 101	1	Switch plate (for metallic screen)	137	245 693	1	Shut-off bar
56	235 150	1	Compression spring	138	209 357	1	Ball φ 3.2
57	247 033	1	Push-button	139	232 104	1	Ball bed
	249 474	1	Push-button (for metallic screen)	140	201 187	1	Slide disc
60	249 325	1	Weight cpl.	141	249 687	1	Magnetic set, lift cpl.
61	246 884	2	Lock nut	142	248 266	1	Tension magnetic, cpl.
62	230 063	1	Threaded pin	143	247 417	1	Armature
63	249 326	1	Frame cpl.	146	245 661	1	Stroboscope prism
64	234 805	1	Compression spring	147	245 648	1	Retainer piece
65	217 438	1	Threaded pin	148	245 235	1	Diode plate
66	249 327	1	Bearing frame cpl.	148	245 235	3	Luminescence diode LD 57 CA

Fig. 17

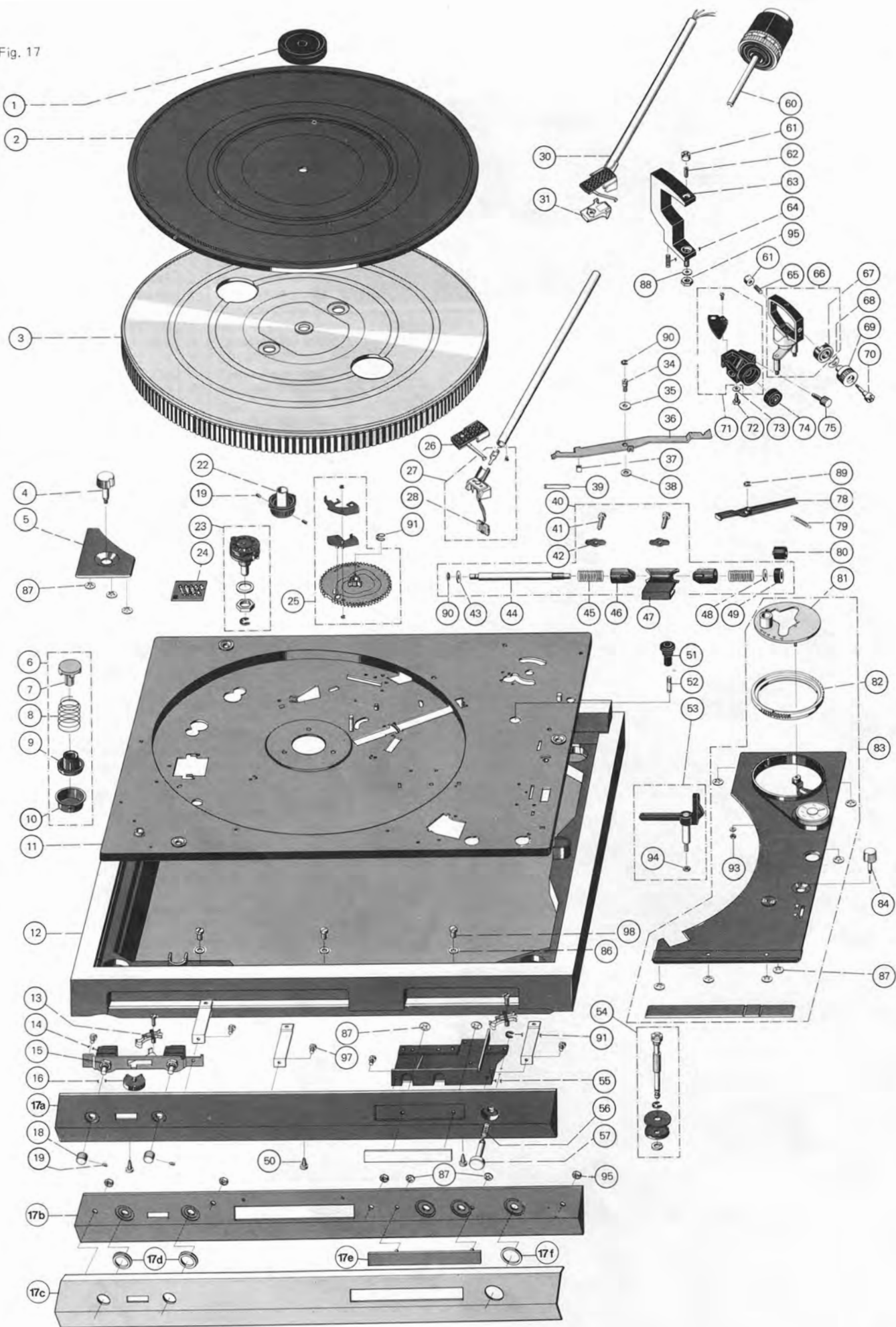

Pos.	Part.-No.	Qty	Description
149	245 699	1	Stroboscope housing
150	249 689	1	Motor electronic system-base plate cpl.
151	249 690	1	Motor electronic system model 1
152	249 691	1	Motor electronic system model 2
153	249 692	1	Motor electronic system model 3
154	245 662	4	Support
155	222 038	4	Rebate plug
156	232 342	1	Female multi-point connector, 2-pole
157	229 864	1	Female multi-point connector, 4-pole
158	226 514	1	Female multi-point connector, 5-pole
159	210 283	1	Cheese head screw B 2.9 x 6.5
160	240 861	2	Cog
161	260 161	1	Solenoid protective circuit cpl.
162	227 443	2	Hexagon screw
163	242 165	1	Return bar
164	242 167	1	Tension spring
165	242 166	1	Disc 3.2/13.6/0.5
166	243 001	1	Compression spring
167	242 161	1	Lift off bar
168	233 710	1	Tension spring
169	234 782	1	Securing disc, threaded
170	210 713	1	Disc 9.0/15/1
171	210 151	1	Securing disc 7
172	242 180	1	Plate
173	242 181	1	Adjusting bar
174	234 784	1	Bearing
175	210 586	1	Disc 3.2
176	235 152	1	Tension spring
177	231 079	1	Cable clips cpl.

Pos.	Part.-No.	Qty	Description
179	242 164	1	Rotary lever
180	203 477	1	Disc 2.7/8/1
181	232 545	1	Plate spring
182	234 776	1	Bearing bar
183	246 886	1	Handle hub cpl.
184	234 778	1	Torsion spring
185	234 777	1	Stroke cam
186	237 543	1	Rubber sleeve
187	243 125	1	Adjusting sleeve
188	260 160	1	Lift plate
189	210 609	1	Disc
190	214 602	2	AMP push-on sleeve
191	209 436	3	Flat push-on sleeve
192	232 996	1	Power cable Europe, cpl.
	232 995	1	Power cable America, cpl.
193	209 424	1	5-pole plug
194	207 303	1	Tonearm cable cpl.
	207 301	1	Tonearm cable with cynch plugs
195	209 425	1	Cynch plug white
196	209 426	1	Cynch plug black
197	246 079	1	Mounting plate
198	237 548	2	Cable conduit
***	248 166	1	Distance roll and screws for TA-mounting
***	211 379	1	Washer 2.1/5/0.5
***	245 546	1	Filister head self-tapping screw B 2.2 x 5.2 (for TA-Removal prevention)
***	247 471	1	Operating instructions
***	247 073	1	Packing carton

Alterations reserved!

Lubricating instructions

All bearing and friction points of the unit are adequately lubricated at the factory. Replenishment of oil and grease is only necessary after approx. 2 years of normal use as the most important bearing points have sintered metal bushes. The motor bearings have long-life sintered metal bushings and thus should not be lubricated. Bearing points and friction faces should be lubricated sparingly rather than generously. When using different lubricants, chemical decomposition can often take place. To prevent lubrication failure, we recommend using the original lubricants shown below.

Fig. 19



Fig. 20

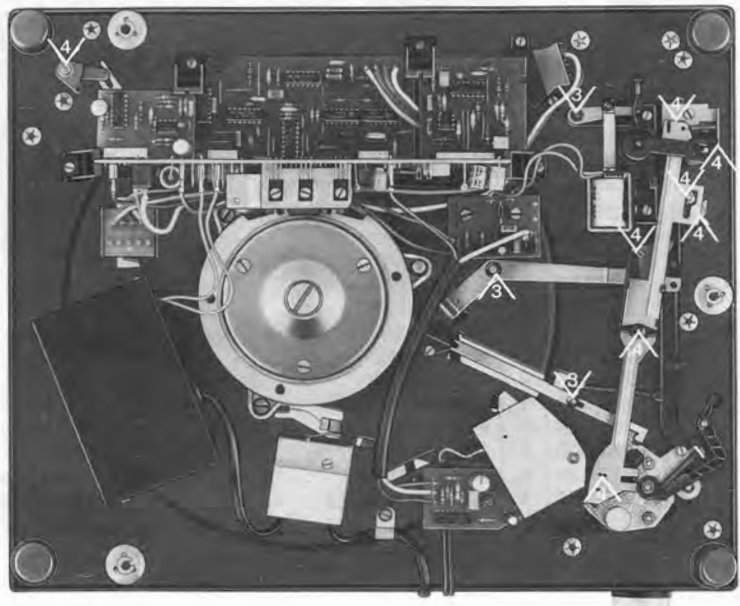

Wacker silicon oil
AK 300 000



BP super viscstatic
10 W/40



Shell alvania No. 2

united audio **SERVICE NOTE**

September 7, 1979

PLEASE NOTE FOLLOWING CORRECTIONS TO CS-714-Q
SERVICE MANUAL:

<u>Posi- tion</u>	<u>Incorrect Part #</u>	<u>Correct Part#</u>	<u>Description</u>
IC 9494	249629	246629	UAA 170 display unit
C 9004	226457	226586	Elyt 1 000/ μ F ME/Base plate



Datum-Date-Date 11.06.79	Zeichen-Ref.-N/réf. KDT/B-fe	Geräte Nr.-Serial number- No. de l'appareil	Gerät-Model-Appareil 714 Q
-----------------------------	---------------------------------	--	-------------------------------

Trittschall-Empfindlichkeit

Bei den ersten Modellen kamen Gewindestücke
mit verkürztem Schaft zum Einsatz

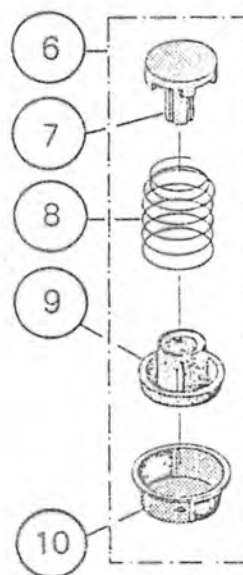

In Reklamationsfällen sind diese durch die
Original-Ausführung

Art.-Nr. 230 529 (Pos. 7 - S.A. 714 Q)

zu ersetzen.