



Edition April 1979

CS 731 Q



Service Manual

Dual Gebrüder Steidinger 7742 St.Georgen/Schwarzwald

Fig. 1 TA-Anschlußschema / Audio Connection Diagram / Schema de branchement / Esquema de conexion del fono captor

a) mit DIN-Stecker 5-polig / with DIN-plug 5 pin
avec fiche DIN 5 pôles / con enchufe DIN de 5 poles

b) mit Cynchstecker / with phono plug
avec fiche cynch / con enchufe Cynch

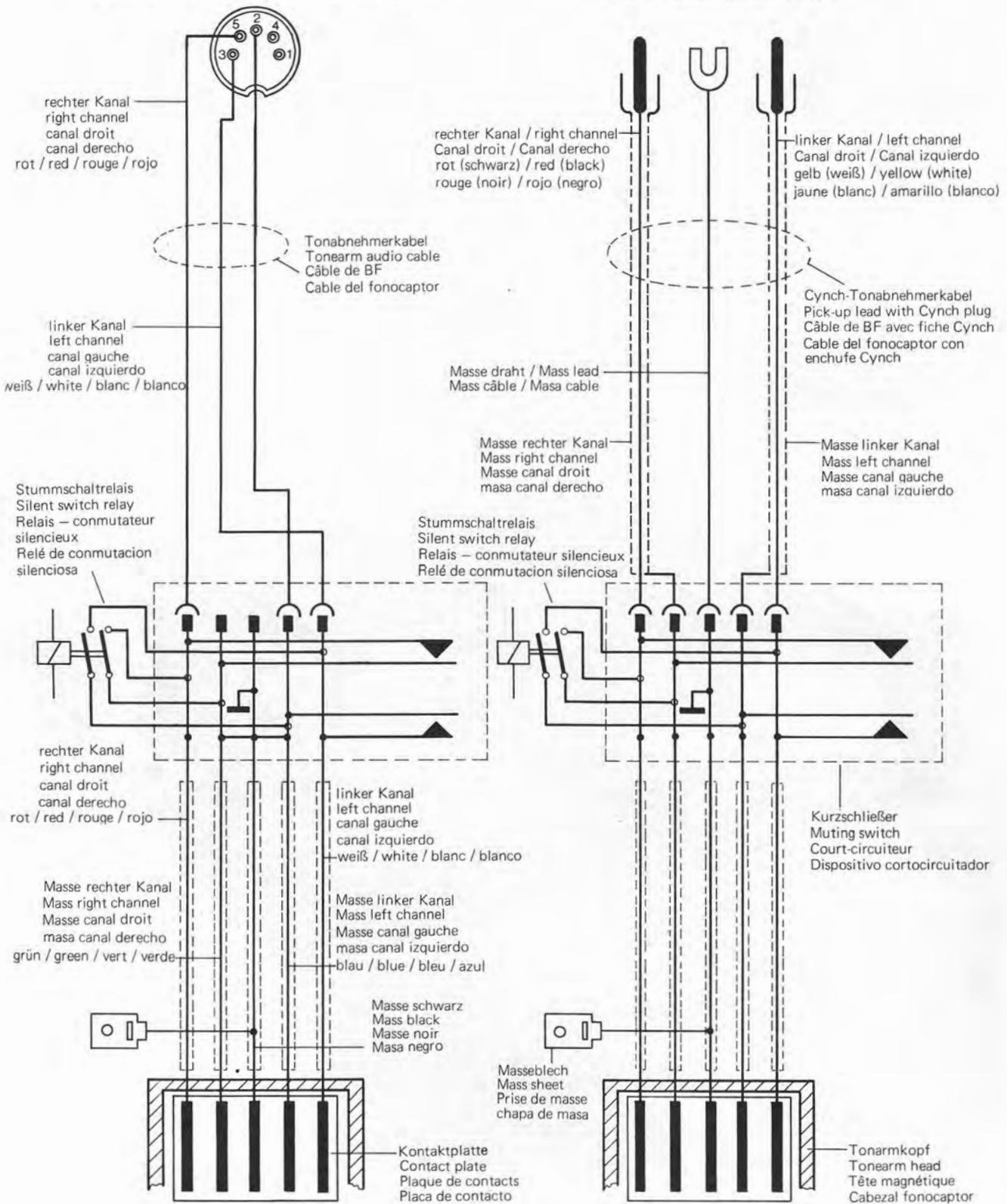

Contents

Page	
2	Tonearm connection diagram
3	Technical data
4	Block diagram
5	Direct drive system EDS 920
5	Wiring diagram
6	General
6	Fascia
6	Motor and drive
6	Replacing motor electronic system
6	Replacing motor mechanical system
6	Pitch control
6	Stroboscope
7	Tonearm and tonearm suspension
7	Fitting a 1/2" cartridge
7	Removal of tonearm from bearing frame
7	Removal of complete tonearm
8	Replacement of spring housing
8	Adjustment of tonearm suspension
8	Anti-skating control
8	Tonearm cue control
8	Adjustment point
8	Replacement of cue control plate
8	Tonearm control
9	Continuous play
9	Starting
9	Manual start
9	Muting
9	Shut-off
10	End of play shut-off
10	Adjustment points
10	Power fuse
10	Tonearm set down point
10	Shut-off point
10	Tonearm lift off height
11	Pull magnet "start/stop"
11	Pull magnet "cueing"
11	Tonearm does not set down
11	Vertical tonearm movement is inhibited
11	Platter does not rotate
11	Tonearm does not set down on edge
11	Motor does not shut-off
12 - 15	Spare parts list with exploded views
16	Lubrication instructions

Technical data

Current type	AC 50 or 60 Hz
Line voltages	110 - 125 V and 220 - 240 V
Drive	Quartz stabilized electronic direct drive system Dual EDS 920, PLL control
Power consumption	Approx. 4 W, motor during play < 50 mW
Run-up time	(until nominal speed is reached) approx. 1.8 s at 33 rpm
Platter	Non-magnetic dynamically balanced, complete rotary mass detachable approx. 1.5 kg
Platter speeds	33 and 45 rpm, electronically switchable, quartz stabilized
Pitch control	In PLL technology, quartz accurate for both speeds, separately adjustable, range of adjustment $\pm 5.5\%$
Speed check	Quartz accurate, illuminated stroboscope with automatic frequency switch-over for 33 and 45 rpm
Sensitivity of light stroboscope for 0.3 % speed deviation	20 graduations per minute
Wow and flutter	DIN < $\pm 0.025\%$ WRMS < $\pm 0.015\%$
Signal-to-noise ratio	Rumble unweighted signal-to-noise ratio > 52 dB Rumble weighted signal-to-noise ratio > 75 dB
Tonearm	Torsion-resistant "ultra-low-mass" aluminum tonearm, in gimbal 4-point suspension, tonearm balance weight with tuning anti-resonator
Effective tonearm length	221 mm
Offset angle	26° 4'
Tangential track error angle	0.16° /cm
Tonearm bearing friction (related to stylus point)	Vertical < 0.07 mN (0.007 g) Horizontal < 0.15 mN (0.015 g)
Tracking force	From 0 - 20 mN (0 - 2 g) infinitely variable with 1 mN (0.1 g) Calibration in range from 2 - 15 mN (0.2 - 1.5 g)
Pick-up head	Detachable, suitable for ultra-low-mass cartridges, with long carrier plate (accessory), also suitable for cartridges with Dual shap-in mounting and for cartridges with 1/2" mounting and a weight of 2 to 9 g (including mounting hardware)
Cartridge Weight	Adjustable overhang: 5 mm See separate data sheet Approx. 8 kg

BLOCKSCHALTBILD

BLOCK DIAGRAM

SCHEMA SYNOPTIQUE

Fig. 2

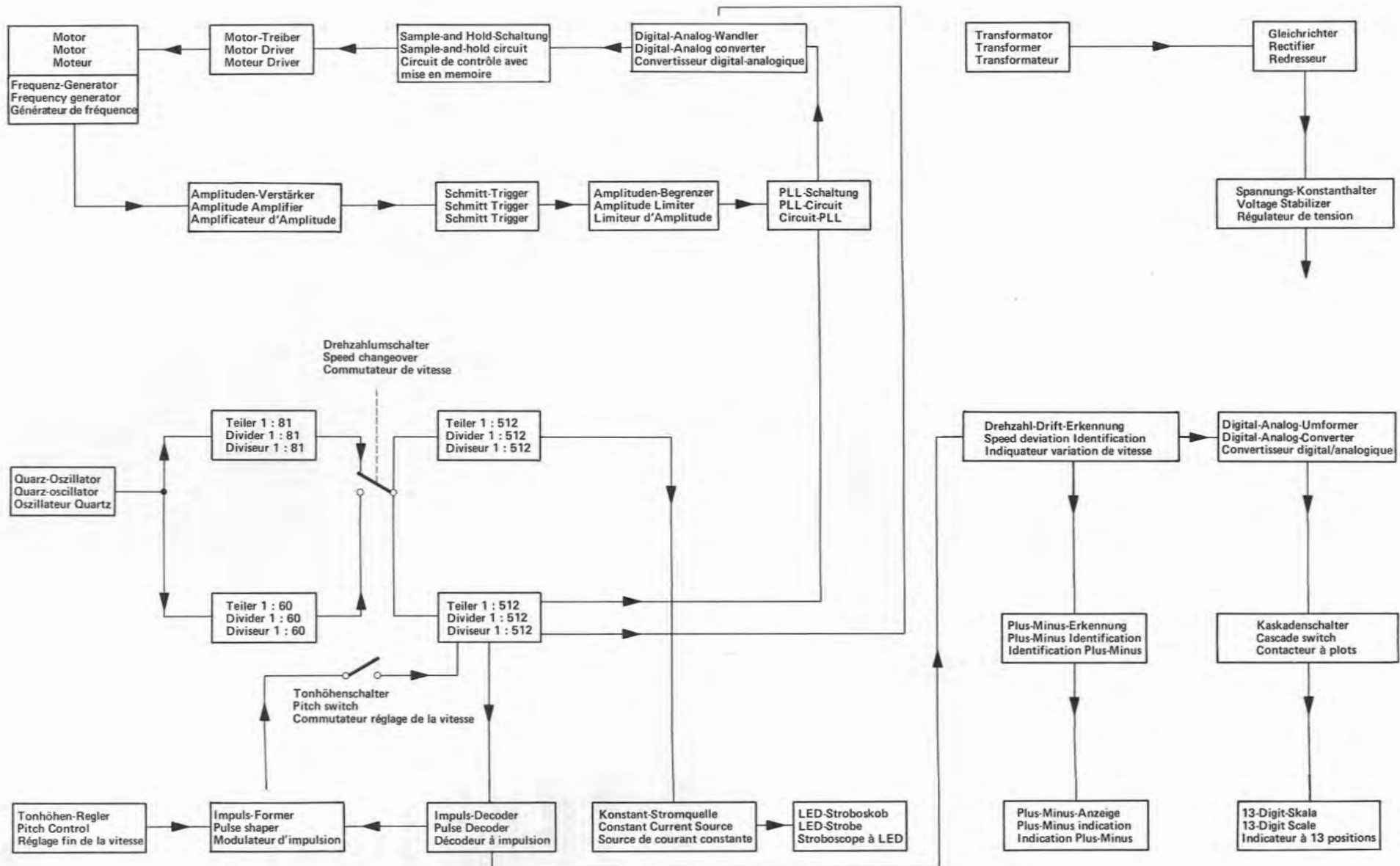

4

EDS 920 direct drive system

The newly developed direct drive system of the CS 731 Q turntable is a successful synthesis of our well-known motor principle and a highly sensitive electronic system which receives its accuracy from a quartz crystal. The drive motor is a DC motor with no commutator in which commutation is carried out by two Hall generators which detect the position of the rotor equipped with an 8-pole ring magnet and which also actuate the corresponding windings of the rigid flat coils. The synchronously rotating magnetic return circuit plate and the ring magnet enclose with a small air gap the non-ferrous coil arrangement so that, on the one hand, the drive system displays an extremely uniform running characteristic without pole sensitivity and which displays, on the other hand, a high torque in spite of the economical energy supply. After the nominal speed has been attained, the energy supply required for maintenance of rotation is less than 50 mW.

Description of function

At a motor speed of $33 \frac{1}{3}$ rpm, the 200-pole frequency generator rigidly coupled to the motor delivers a frequency of 111 Hz which is amplified in the input amplifier and prepared in the cam form. This signal is applied as an actual value to the PLL circuit. An oscillation frequency of 4.608 MHz, which is controlled by a highly precise quartz crystal, is generated in the quartz oscillator. The actual reference frequency — that is to say, the set value — is derived from the oscillator frequency by a multi-stage divider. In the PLL circuit, the actual value and set value are compared with one another as regards amount and phase. In the case of the slightest deviation, a control pulse is applied to the digital/analog converter which obtains from this an analog control signal which is converted into a current alteration in the subsequently connected motor control circuit. In the drive motor, this current alteration causes spontaneous stabilization of the minimal speed deviation.

Fig. 3

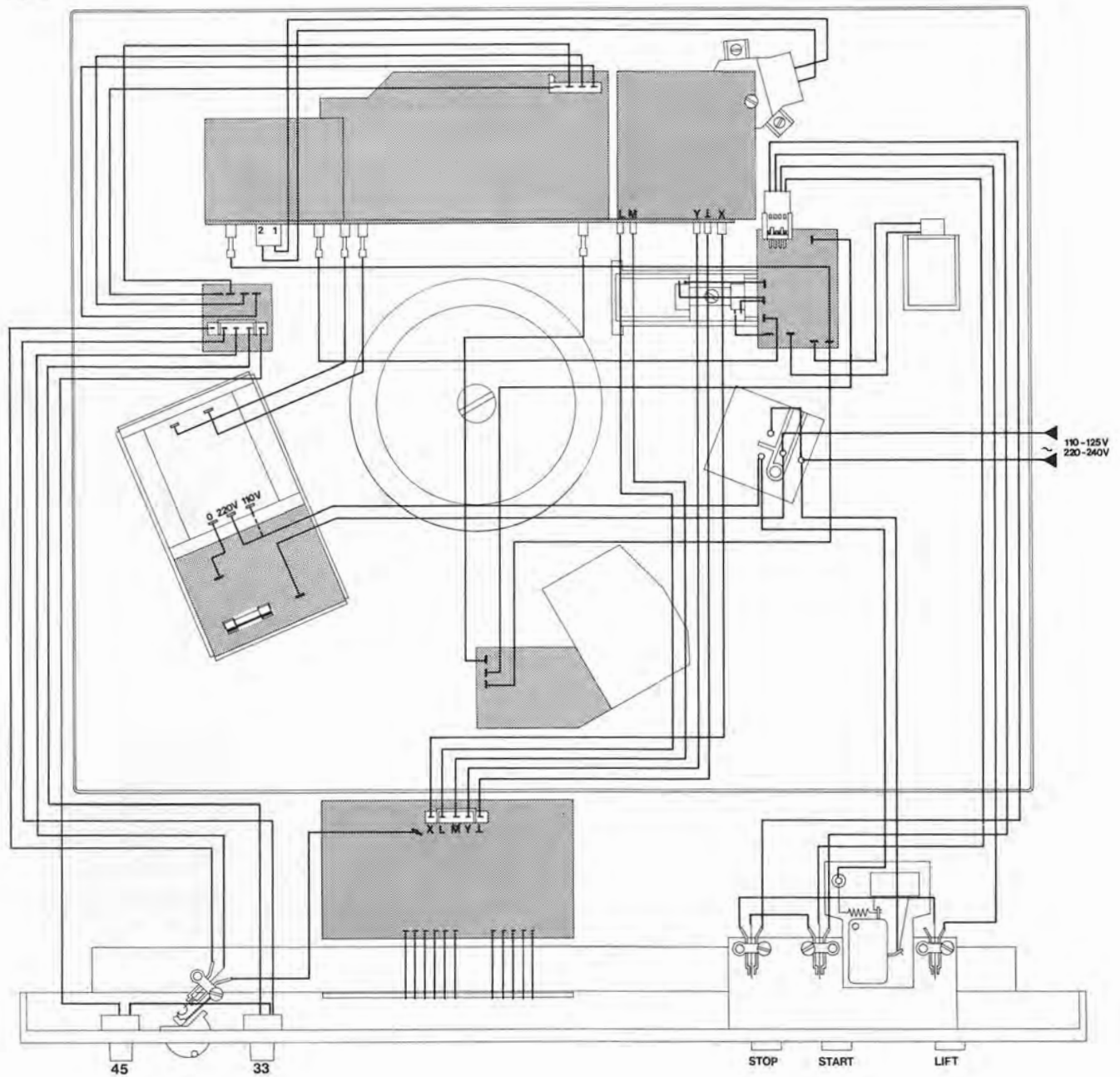

The set value necessary for the 45 rpm speed is generated in the voltage divider by alteration of the divider ratio. For pitch control, a continuously variable control signal, with which the control loop is fed, is obtained by means of a complicated division process.

Thus the complete control range, like the nominal speeds, is coupled in a locked-phase relation to the quartz oscillator. The speed accuracy in the pitch range is practically the same as in the case of nominal speed. The speed deviation preselected with both pitch controls is maintained even if the pitch switch is operated or if the unit is switched off.

In the speed logic, the display unit of the CS 731 Q obtains from the actual speed the basic information as to whether the actual speed of the nominal speed is faster or slower. A further logic system activates the plus or minus sign of the display unit. Both signals are dark at rated speed.

From the digital information on the actual speed, a further digital/analog converter receives relative and analog information which is transformed in the cascade switch to an activation voltage for the 13 digital displays. In the display itself the information is still completely analog as the individual digits are activated with differentiated voltages and light up accordingly.

This display is as accurate as it is practical. The power section supplies the various partial circuits with carefully filtered and stable operating voltages.

General

The listed item numbers refer to the following spare parts lists and exploded views.

The cover can be easily withdrawn from the hinged splice pieces. To remove the turntable, remove both fillister head screws (98) and the discs (86) with which the mounting plate (197) is screwed down. The turntable can be lifted out of the bracket (12) after disengaging the three transport locking screws.

Now detach the following plug connections:

- 1) Both single-pole plugs (122) on power switch (106).
- 2) The 4-pole plug (160) on the solenoid protective circuit (185).
- 3) The 5-pole female multi-point connector (158) at the display unit (35).
- 4) The 5-pole female multi-point connector (185) at the distributor board (24).

Fascia

To dismantle the fascia, remove both attachment screws (21) with which the display unit is mounted on the bracket base bracket base.

The top of the plate (17) is attached with 3 fillister head screws (98) and three washers (86) and the bottom is attached with three cheesehead screws (50).

Fig. 4

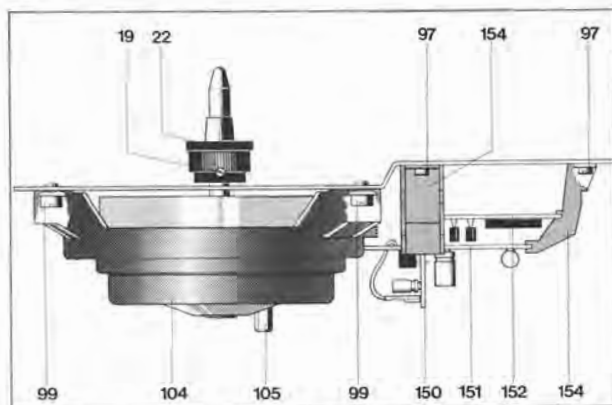

Motor and drive

Special tools and measuring instruments are necessary for repair of the Dual EDS920. Therefore, work on the motor or the motor electronic system should only be carried out by an authorized Dual service station.

Replacement of the motor electronic system, complete

The individual modules (151/152/153) are plugged into the main board. In addition, they are held by means of supports (154). Moreover, module 1 is also secured with the fixing screw (159). When replacing the complete motor electronic system, proceed as follows:

- 1) Remove the fillister head screws (97) and the four supports (154).
- 2) Remove fixing screw (159) (module 1).
- 3) Detach the plug connections for the connection cable — refer to wiring diagram Fig. 3.
- 4) Detach the motor electronic system completely from the mechanical system of the motor and replace it.

Replacement of the mechanical system of the motor

- 1) Release both threaded pins (19) and withdraw plate cone (22).
- 2) Remove the complete motor electronic system — see above. The plug connections of the connecting cable need not be removed.
- 3) Remove both fillister head screws (99) and the cog (105).
- 4) Withdraw the mechanical system of the motor and replace it.

Fig. 5

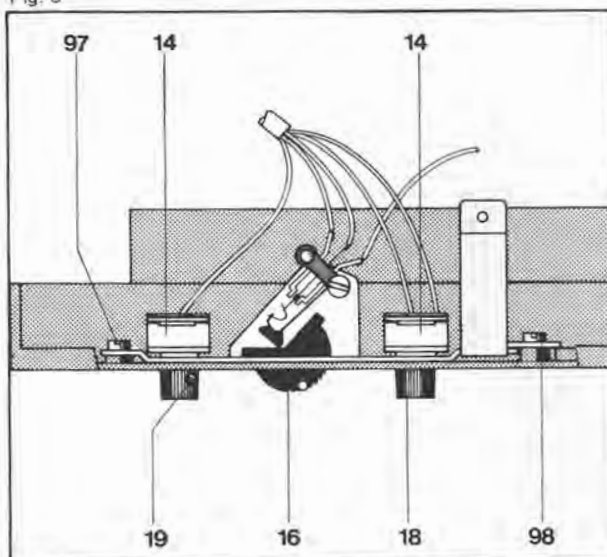

Pitch control

With the pitch control, each of the two rated speeds, 33 1/3 and 45 rpm, can be varied by $\pm 5.5\%$. With the seesaw switch (16) at "ON" position, each nominal speed can be altered by means of a separate potentiometer (14). At the same time, the optoelectronic display scale (35) indicates the percentage deviation from the nominal speed.

Independently of the potentiometer setting (14), the speed corresponds with quartz precision to the respectively switched nominal speed, if the seesaw switch (16) is in "OFF" position.

Stroboscope

The stroboscope markings on the turntable edge are flashed from the diode plate (148) by means of quartz accurate frequency. The display is independent of power frequency and does not require additional stroboscope markings for different speeds and line frequencies.

When the stroboscope markings seem to be stationary both nominal speeds (33 1/3 and 45 rpm) are accurately adjusted. If the markings seem to run ahead the speed is higher. If the markings seem to run back the speed is lower than the nominal speed. By means of the speed of the apparently "wandering" markings the speed selected with potentiometer (14) can be determined at high speeds: 1 graduation/sec. = 0.9 % deviation. After releasing the fixing screw (159) and removing both fillister head cap screws (96) the stroboscope housing can be removed (149). After removing the retainer piece (147) the three LED's (148) can be replaced.

Tonearm and tonearm suspension

The light, torsion-resistant all-metal tonearm is twingimbal mounted. Suspension is by means of four hardened and precision polished steel points which rest in precision ball bearings. The tonearm bearing friction is thus reduced to a minimum.

Bearing friction vertical	0.07 mN (0.007 g)
Bearing friction horizontal	0.15 mN (0.015 g)

as related to stylus point.

This ensures extremely favorable pick-up conditions. Before setting the tracking force corresponding to the built-in pick-up cartridge the tonearm is balanced at 0 position of the tracking force scale. Coarse adjustment is carried out by moving the weight with stem (60) subsequent fine adjustment by turning the front knurled ring on the weight.

The balance weight is designed so that pick-up cartridges having a dead weight (including fitting material) of 2 – 9 g can be balanced. The tracking force is produced by tensioning the coil spring fitted in the spring housing (74). The rotary knob (69) is provided with a scale which permits accurate adjustment of the tracking force in the range from 0 – 20 mN (0 – 2 p) by means of the marking dots.

Fitting a 1/2" cartridge

The description of retrofit for fitting a 1/2" cartridge (replacement of carrier plate etc.) should be taken from the operating instructions.

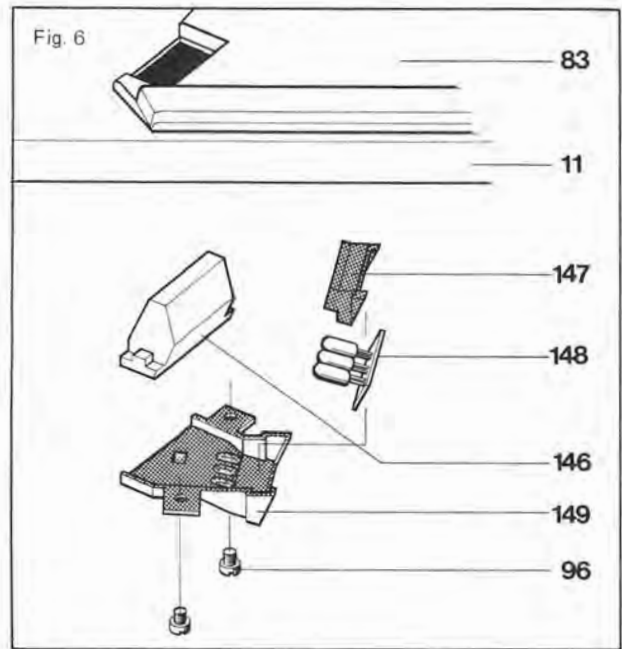

Removal of tonearm from bearing frame

- 1) Secure unit in repair jig. Remove weight (60). Unscrew tensioning screw (52). Set rotary knob (63) to 0.
- 2) Turn unit upside down. Remove hexagon nut (34) and screening plate (119). Unsolder tonearm leads on muting switch (120).
- 3) Unscrew tensioning screw (70). Remove rotary knob (69), disc (68) and indicator (67).
- 4) Loosen locking nut (61) and unscrew threaded pin (65).
- 5) Remove tonearm (30) with bearing (71).

Assembly takes place in reverse order.

Removal of tonearm assembly with tonearm bearing

Proceed as follows:

1. Secure unit in repair jig. Set rotary knob (69) to 0. Lock tonearm (30). Remove weight (60).
2. Turn unit upside down. Remove hexagon nut and screening plate (119). Unsolder tonearm leads on muting switch (120).
3. Remove retainer disc (91). Remove main lever (167) and bearing block (166). Remove securing disc (89). Lift off adjusting bar (168) and rotary bearing (170) and swivel to motor.

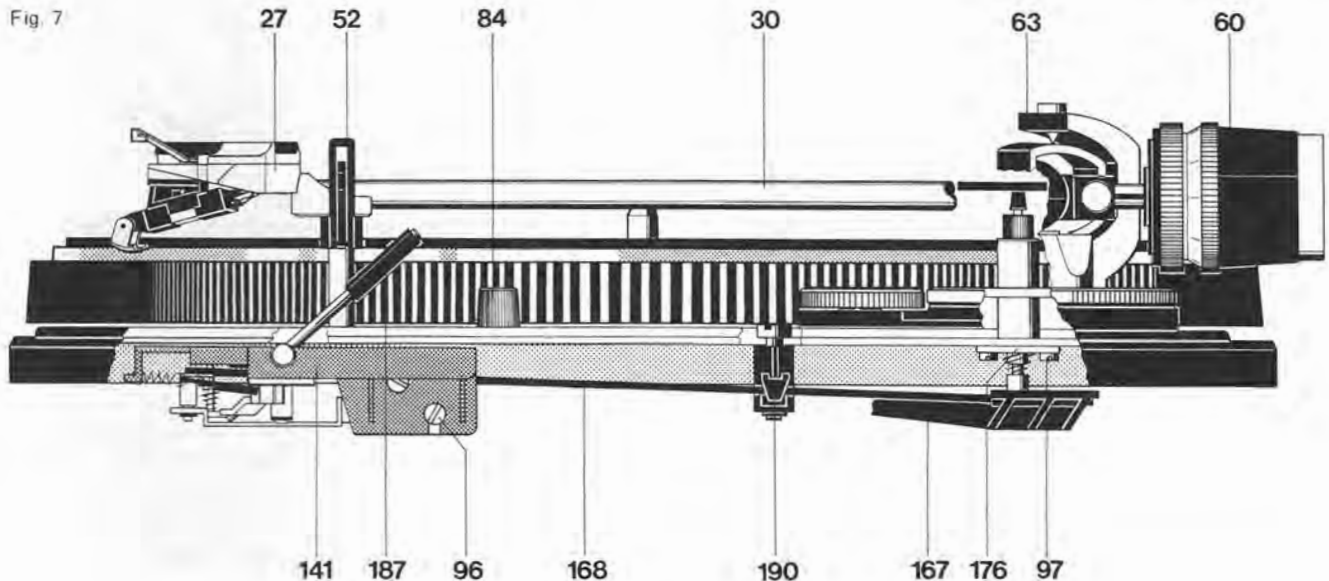

4. Disengage tension spring (136). Release securing disc (90) and remove skating lever (134).
5. Remove hexagon nuts (94). Remove countersunk screw (138). Remove counterbearing (135) and segment (124).
6. Retain tonearm (30) and frame (63). Remove filister head cap screw (88). Remove tonearm complete with tonearm bearing.

When fitting the tonearm proceed in reverse order but ensure that the threaded pin (62) seats correctly on ball bearing.

Replacing spring housing

Remove tonearm (30) from bearing frame (66) as described above.

When installing notice that the helical spring engages in the cut-outs of the bearing (71). Mount tonearm (30) again. Set bearing play as described below using threaded pin (65) and lock nut (61).

Adjusting the tonearm bearing

First balance tonearm accurately. Both bearings must have slight, just perceptible play. The horizontal tonearm bearing is correctly adjusted when at anti-skating setting 0.5 and being touched it slides in without resistance. The vertical tonearm bearing is correctly adjusted when it swings in after being touched. The play of the horizontal tonearm bearing should be adjusted with threaded pin (62), the play of the vertical tonearm bearing with threaded pin (65).

Anti-skating device

Adjustment of anti-skating force is carried out by means of turning the knurled ring on the cover. According to adjustment the asymmetrical cam disc guides the skating lever (134) from the tonearm pivot point. The anti-skating force is transmitted to the segment (124) by means of tension spring (136) and to the tonearm.

Optimum adjustment is carried out at the works for styli with a tip radius of 15 μm (conical), 5/6 x 18/22 μm (elliptical) and CD 4 cartridges.

Any alteration can only be carried out with the aid of a Dual skate-0-meter and a test record and should only be done by an authorized Dual service station.

Cue control

By moving lever (187) forward (▼) lift cam (188) rotates. The slide bar (168) connected to it transmits this movement to the lift pin which then raises the tonearm. As a result the cue control permits set down and lift off of the tonearm at any desired point outside the shut-off range.

The slide bar (168) is released again by moving the cue control lever (187) to the rear (▲). As a result of the action of compression spring the lift pin is returned to neutral position and thus lowers the tonearm. Lowering of the tonearm is damped by silicone oil in the lift tube.

The set down speed can be varied by adjusting the pretension of compression spring (lift plate 176). According to operation of the adjusting ring (82) in position "▲" the lowering speed is slower, in position "◀◀◀" it is faster.

Adjustment point

The lift height can be varied by turning adjusting screw (51). The distance between record and stylus should be approximately 5 mm.

Fig. 8

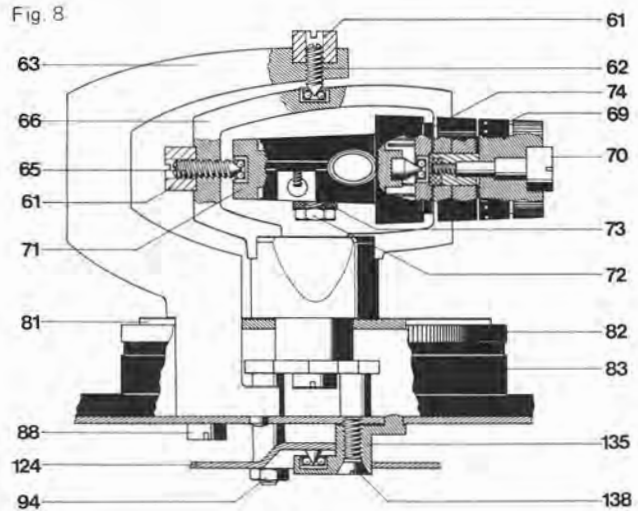

Replacement of cue control plate

Replace cue control plate as follows:

1. Fix unit on repair jig and lock tonearm. Turn unit upside down.
2. Remove securing disc (89). Detach main lever (167) and bearing block (166).
3. Remove securing disc (89). Remove adjusting bar (168) and rotary bearing (170) and swivel to motor.
4. Remove both filister head cap screws (97), remove cue control plate complete (176).

Fitting takes place in reverse order. It should, however, be noted that the pressure piece in the cue control plate (176) engages correctly in adjusting ring (82) (varying the lowering speed).

Fig. 9

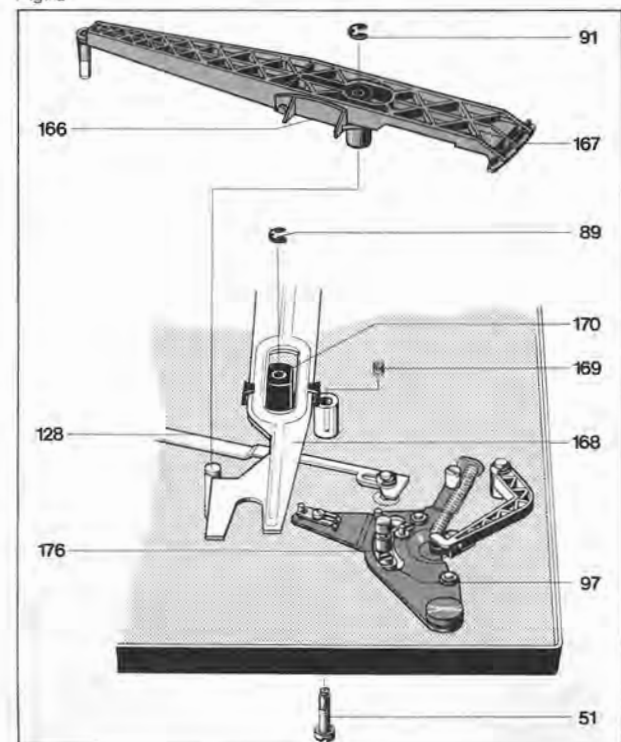

Tonearm control

Automatic movement of the tonearm is indicated by the control cams on the inside of the cam wheel (16) on rotating through 360°.

The control elements for raising and lowering are the control lever (167) and the lift pin, for horizontal movement of the tonearm control lever (167) with segment (124).

The automatic set down point is designed for 30 cm and 17 cm records and is coupled to the platter speed changeover. Set down points of the tonearm are determined by means of stop of spring bolt of segment (124) at the adjusting bar (168). Limitation of the horizontal movement of the tonearm is produced by stop of segment on adjusting bar (168) which is lifted off only during set down by the main lever (167) and reaches the swivel range of the spring bolt on the segment. On completion of set down (lowering of the tonearm onto the record) slide bar (168) is released again and returns to its neutral position. As a result, this is outside the range of the spring bolt so that unimpeded horizontal movement of the tonearm is possible for playing.

Continuous automatic play

The continuous automatic play is operated by turning knob (84) to "00". Switch bracket (179) is actuated by knob (84). Switch rod (180) keeps change lever (165) in start position. After playing the record the tonearm returns automatically to the lead in groove of the record. This process will be repeated until knob (84) is in position "1".

Adjustment point

Withdraw power plug. Remove turntable (3). Bring knob (84) to position "00". Turn cam wheel to center position. The changeover lever deflects the cam follower lever (U). By this means the cam follower lever tip must be brought at least to the cam track center. Adjustment by bending the switch rod (189).

Starting

Operation of push-button (59) "start" results in the following functions:

- The right hand pull magnet (142) operates cam follower lever (165). At the same time the power switch (106) is operated by the contact arm (127) coupled to the switching arm (78) and the motor and turntable start to rotate.
- This operation also releases start slide (39) which is drawn in the direction of the cam wheel by means of the tension spring (38). By this means the shut-off lever (8) on the cam wheel (25) is brought into the range of the follower (M) (plate cone 22) and the cam wheel driven by this means.

Manual start

The detent (126) coupled to control arm (78) engages in the square plate (125) when the tonearm is moved inward by hand and retains the tonearm in this position. The power switch is operated by the control arm and thus the motor and platter start to rotate. After reaching the run-out groove of the played record return of the tonearm and shut-off of the unit take place automatically. If, on the other hand the tonearm is lifted off the record before playing is completed and moved onto the rest by hand, the pin of segment (124) disengages the detent (126) so that the control arm is returned to its starting position. As a result, the power switch shuts off the power supply.

Muting switch

To prevent disturbing noises during automatic operation of the tonearm the unit is fitted with a muting switch. Control of the switch springs for both channels is effected by the cam wheel. With the unit in neutral state the short-circuit of the pick-up leads is eliminated.

Adjustment point

In neutral position of the cam wheel a contact distance of approximately 0.5 mm should be present between contact springs (F) and short-circuit strips (L). If necessary bend short-circuit strips.

Spray contact springs with suitable means.

Fig. 10

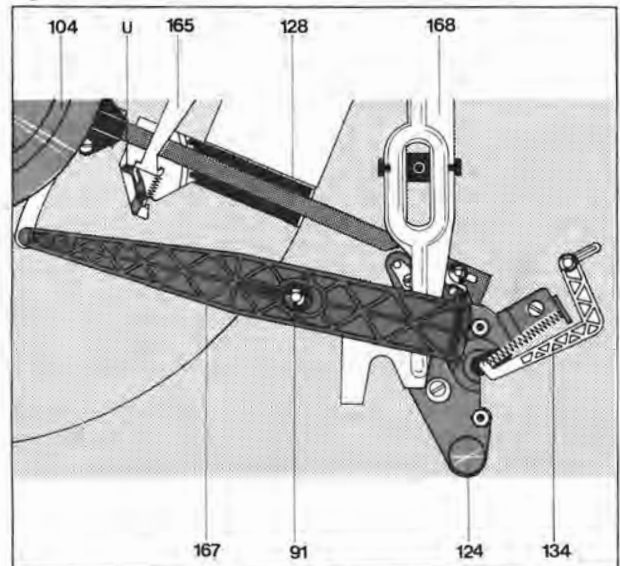

Fig. 11

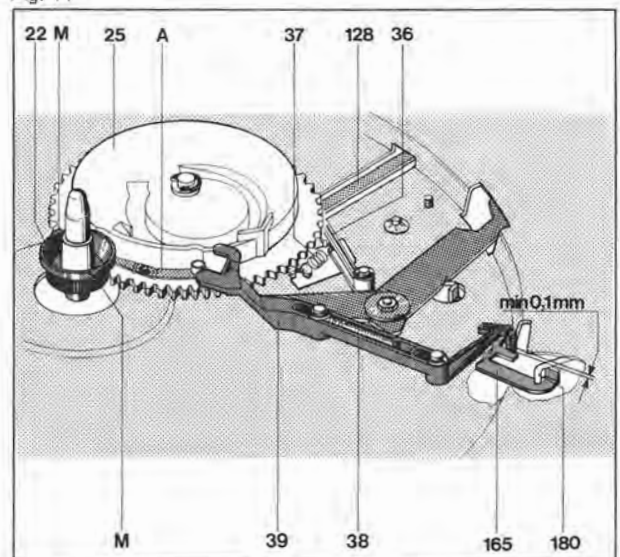
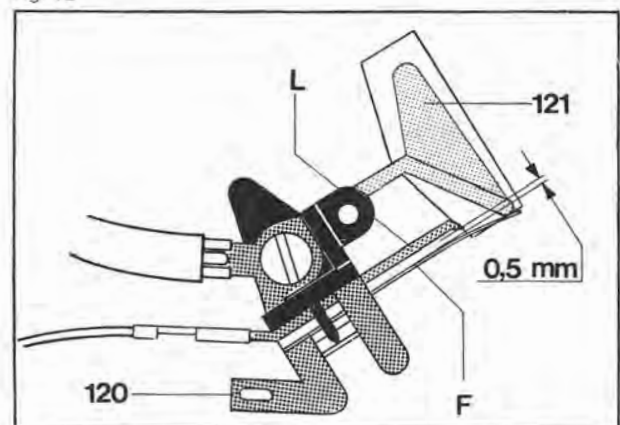

Fig. 12



Stopping

When push-button (59) "stop" is operated the changeover lever (165) is brought into stop position by means of the left hand pull magnets (142). As a result the start slide is released which is drawn in the direction of the cam wheel by means of tension spring (38). By this means the shut-off lever is brought into the range of the follower on the platter pinion (PR) and the cam wheel (25) is thus driven.

Shut-off operation

The functions of end switch-off and stop switching are determined by the position of the deflection lever (U). The deflection lever (U) is brought to stop position by the main lever (167) after every start operation (longer end of deflection lever to cam wheel center).

After playing of a record shut-off is initiated by the follower (M) of the platter (3) and the shut-off lever (A).

The shut-off bar (128) is only moved synchronously by the bolts of the segment (126) in the shut-off range.

In the shut-off range (records 116 to 122 mm ϕ) the shut-off lever (A) is guided onto the follower (Fig. 13 a) by the shut-off bar (128). The follower (M) engages shut-off lever (A). By this means cam wheel (25) is brought out of zero position in engagement with pinion of platter (Fig. 13 b). The main lever (167) guides the tonearm back and effects tonearm lowering onto the support.

During run-in of the cam wheel into zero position the roller (76) of the switching arm (78) run-in to the cut-out provided on the cam wheel and operate the power switch (106).

Adjustment points

Power fuse

After removing both fastening screws and detaching power section cover the fuse (102) on the power plate (101) can be replaced.

Tonearm set down point

The set down point of the tonearm can be altered with the eccentric bolt (172). If the stylus sets down too far in or out on the record turn the eccentric bolt (172) correspondingly right or left.

Shut-off point

The shut-off point (shut-off range records 116 – 122 mm ϕ) can be altered with the eccentric (E) on the segment (124).

Tonearm lift-off height

The tonearm lift-off height (during automatic operation) can be altered with adjusting sleeve (177). Withdraw power plug. Unlock tonearm. Rotate cam wheel (25) out of zero position until tonearm has reached its highest point.

The tonearm should be approximately 5 mm above the tonearm support stop (Fig. 16). If necessary, turn adjusting sleeve (177) to left or right.

Fig. 13

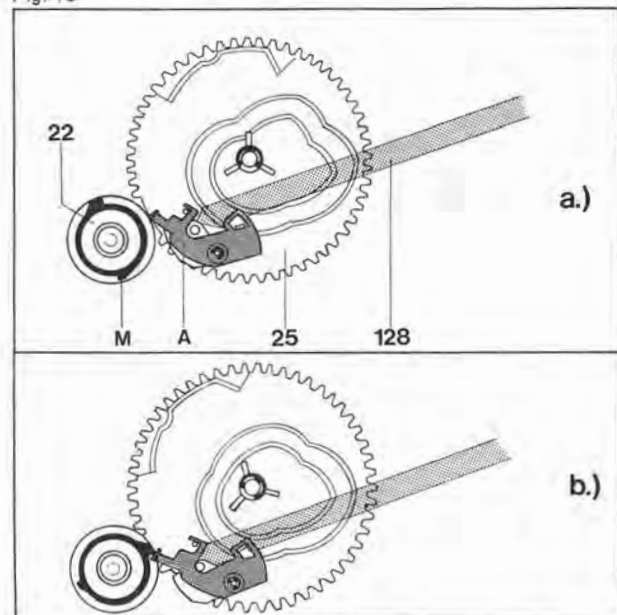

Fig. 14

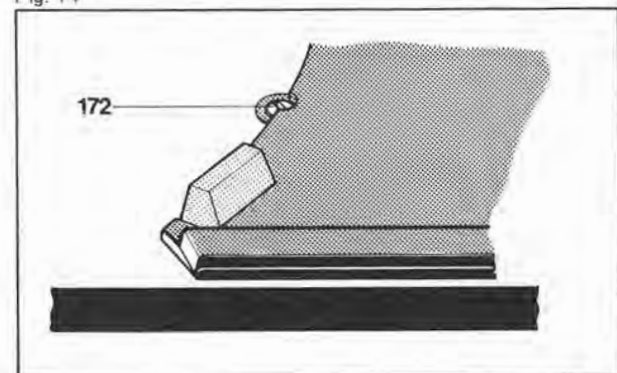

Fig. 15

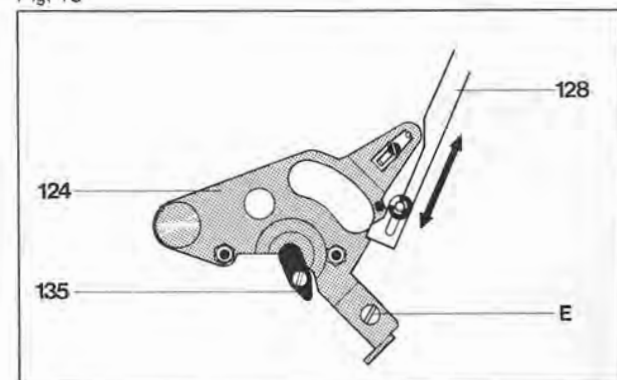

Fig. 16

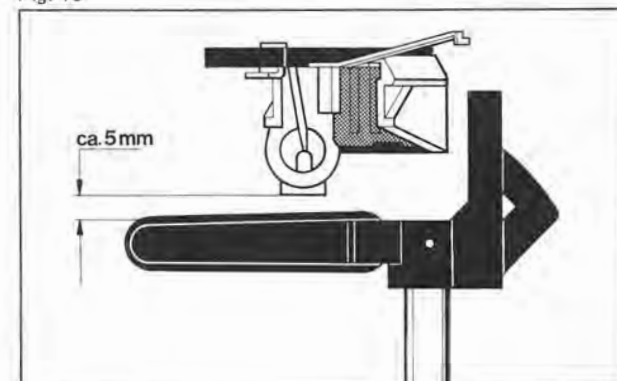

Fig. 17

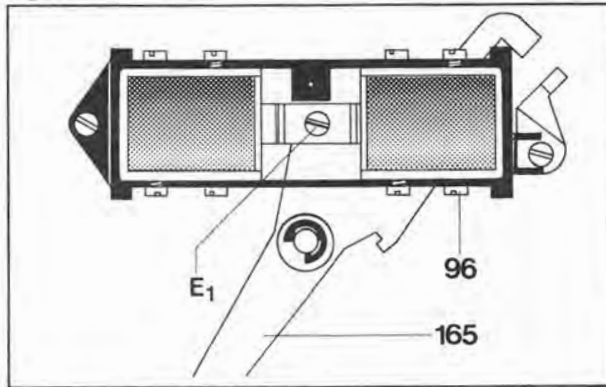

Fig. 18

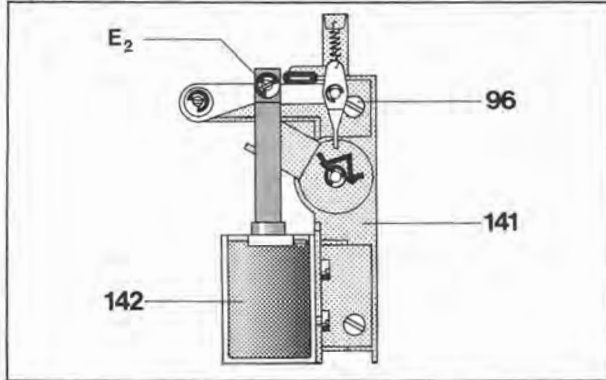
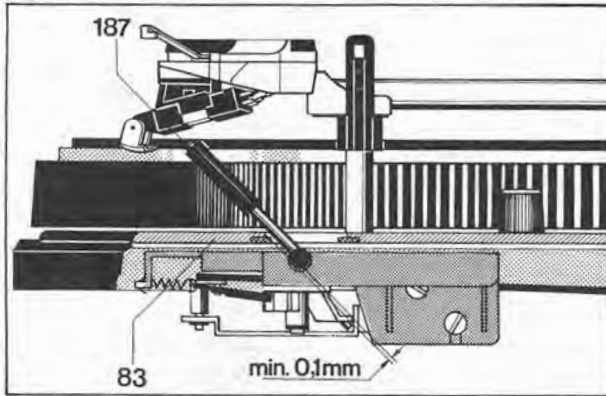

Fig. 19



Defect	Cause
Tonearm does not set down or sets down too quickly after operating cue control lever (187).	Damping excessive or too low by contamination of the silicone oil.
Vertical tonearm movement is inhibited	a) Lift pin (205) jammed in guide tube
Platter does not rotate after connection of unit and moving in of tonearm	Defective power fuse (102)
Tonearm does not set down on the edge of the record	Tonearm set down point incorrectly adjusted
Motor does not switch off when tonearm sets down on rest.	Suppression capacitor (110) in power switch is defective (short-circuit).

Pull magnet "start/stop"

The stroke of the pull magnets can be altered with eccentric (E₁). The stroke should be set so that during "start" operation a play of minimum 0.1 mm is present between the lap of the deflection lever (165) and the start slide (39). See Fig. 11.

Pull magnet "lift"

The stroke of the pull magnets can be altered with eccentric (E₂). During operation of the pull magnet up to stop the lever (187) should still just evidence perceptible play (min. 0.1 mm).

Safety regulations

Service operations on electronic units may only be carried out by specialized personnel. The unit should then be driven by an isolating transformer. The safety regulations in accordance with VDE 0860 H should always be observed during repair. In addition, construction features of the unit should not be altered in any way which reduces their safety e.g. covers, mechanically secured leads, creepage and error distances and components must correspond to the original spare parts list and be correctly fitted again (production condition). After repair it must be ensured that all conductive components which can be touched from the outside do not carry mains voltage.

Remedy

Dismantle cue control plate (176). Detach control stud (175). Remove securing disc (178). Unscrew setting sleeve (177). Remove second securing disc. Remove lift pin. Clean lift tube and lift pin. Grease lift pin uniformly with "Wacker silicone oil AK 300 000". Assemble components again.

See above, if necessary renew cue control plate (176).

Renew power fuse (102).

The tonearm set down point can be adjusted with eccentric pins (172).

Renew suppression capacitor in power switch.

Replacement Parts

Pos.	Part.-No.	Qty.	Description	Pos.	Part.-No.	Qty.	Description
1	220 213	1	Centering piece	57	247 021	1	Switching plate
2	249 308	1	Turntable mat cpl.	260 101	1	Switching plate (for metallic fascia)	
3	249 309	1	Platter cpl.	58	235 150	3	Compression spring
4	245 695	1	Rotary knob	59	247 033	3	Push-button
5	249 310	1	Speed control lever	249 474	3	Push-button (for metallic fascia)	
6	234 432	2	Spring suspension cpl.	60	249 325	1	Weight, cpl.
	234 433	1	Spring suspension cpl. (TA side front)	61	246 884	2	Lock nut
	237 227	1	Spring suspension cpl. (TA side rear)	62	230 063	1	Threaded pin
7	230 529	4	Threaded piece	63	260 222	1	Frame cpl.
8	232 842	2	Compression spring	64	232 551	1	Compression spring
	232 843	1	Compression spring (TA side front)	65	217 438	1	Threaded pin
	236 711	1	Compression spring (TA side rear)	66	260 224	1	Bearing frame
9	200 723	4	Rubber damper	67	246 874	1	Pointer
10	200 722	4	Steel cup	68	247 325	1	Securing disc, threaded 5.2/10
11	260 215	1	Mounting cpl.	69	247 136	1	Rotary knob
12	249 312	1	Base CK 70, walnut	70	246 882	1	Tensioning screw, long
	249 314	1	Base CK 70, agate black	71	260 226	1	Bearing cpl.
	249 315	1	Cover CH 16	72	244 103	1	Hexagon self-tapping screw 2.9 x 6.5
13	244 889	4	Microswitch	73	244 244	1	Disc 3.05/6/1.5
14	247 042	2	Potentiometer	74	249 655	1	Spring housing
15	237 782	2	Potentiometer nut	75	246 883	1	Tension screw
16	246 871	1	Seesaw switch	76	242 785	1	Roller
	249 477	1	Seesaw switch (for metallic fascia)	77	242 768	1	Extension bush
17 a	260 217	1	Fascia cpl., agate black	78	247 301	1	Switching arm
b	260 978	1	Fascia carrier cpl. (for metallic fascia)	79	242 167	1	Tension spring
c	260 975	1	Bracket fascia, metallic silver	80	234 838	1	Adjusting wheel
	260 976	1	Bracket fascia, metallic brown	81	247 024	1	Disc
d	249 476	2	Ring (for metallic fascia)	82	247 023	1	Adjusting ring
e	260 979	1	Identification plate (for metallic fascia)	83	260 227	1	Cover cpl.
f	249 473	3	Ring (for metallic fascia)	84	245 685	1	Rotary knob
18	247 191	2	Rotary knob	85	210 155	2	Toothed disc A 3.2
19	242 191	4	Threaded pin M 3 x 3	86	210 586	9	Disc 3.2
21	247 039	2	Fillister head self-tapping screw BZ 2.9 x 6.5	87	200 444	12	Spring disc
22	242 192	1	Platter cone	88	242 677	1	Fillister head screw M 4 x 8
23	245 663	1	Rotary switch	89	210 145	5	Securing disc 2.3
24	246 237	1	Distributor plate cpl.	90	210 146	7	Securing disc 3.2
25	246 035	1	Cam wheel	91	210 147	3	Securing disc 4
26	249 319	1	Carrier plate cpl.	92	210 539	3	Fillister head self-tapping screw B 2.9 x 13
	249 320	1	Carrier plate 1/2"	93	210 353	1	Hexagon nut M 2
27	249 318	1	Tonearm head	94	210 362	7	Hexagon nut M 3
28	237 223	1	Contact plate	95	210 366	1	Hexagon nut M 4
29	247 836	2	Fillister head self-tapping screw B 2.9 x 19	96	210 469	8	Fillister head screw M 3 x 3
30	249 332	1	Tonearm cpl.	97	210 472	5	Fillister head screw M 3 x 4
31	249 323	1	Fastening TK 26	98	210 486	4	Fillister head screw M 3 x 8
32	260 218	1	Display unit cpl.	99	210 516	2	Fillister head screw M 4 x 8
33	235 851	14	LED, green LD 37/1	100	210 517	4	Fillister head screw M 3 x 30
	246 869	1	LED, red LD 30/1	101	246 133	1	Power plate cpl.
34	246 869	1	Carrier	102	209 719	1	Fuse insert T 0.125 A/250 V
35	260 220	1	Scale cpl.	103	249 657	1	Power transformer cpl.
	260 977	1	Scale cpl. (for metallic fascia)	104	249 658	1	Motor mechanical system cpl.
36	247 307	1	Brake lever	105	247 062	1	Cog
37	226 351	1	Tension spring	106	260 228	1	Power switch cpl.
38	233 710	1	Tension spring	108	233 012	1	Switching plate cpl.
39	242 786	1	Start slide	109	236 335	1	Slide
40	236 843	1	Hinge cpl.	110	241 883	1	Capacitor 10 μ F
41	210 286	2	Cheese head self-tapping screw B 2.9 x 9.5	111	242 822	1	HF choke 47 μ H
42	231 767	2	Retainer plate	112	230 148	1	Switching angle
43	210 668	1	Disc 5.3/10/1	113	219 200	1	Snap action spring
44	231 654	1	Hinge pin	114	239 732	1	Tension spring
45	234 145	2	Compression spring	115	247 547	1	Cover cpl.
46	231 656	2	Hinge cam	116	210 498	1	Fillister head screw M 3 x 28
47	231 657	1	Hinge tongue	117	249 685	1	Muting circuit cpl.
48	236 092	1	Disc 6.2/10/1	118	247 515	1	Threaded pin
49	234 837	1	Adjusting nut	119	247 516	1	Screening plate
50	247 353	3	Cheese head self-tapping screw B 2.9 x 13	120	242 612	1	Muting switch cpl.
51	242 770	1	Adjusting screw	121	242 182	1	Contact arm
52	249 324	1	Rest cpl.	122	233 423	2	Single-pole plug
53	239 414	3	Transport lock cpl.	123	247 303	1	Switching bar
54	247 836	2	Fillister head self-tapping screw B 2.9 x 19	124	260 229	1	Segment
55	247 040	1	Microswitch	125	239 915	1	Square plate
	241 646	1	Capacitor 10 μ F	126	247 764	1	Pawl
	242 822	1	HF choke 47 μ H	127	247 308	1	Contact arm
56	260 221	1	Housing cpl.	128	247 300	1	Shut-off bar
				129	209 357	1	Ball ϕ 3.2

Fig. 20

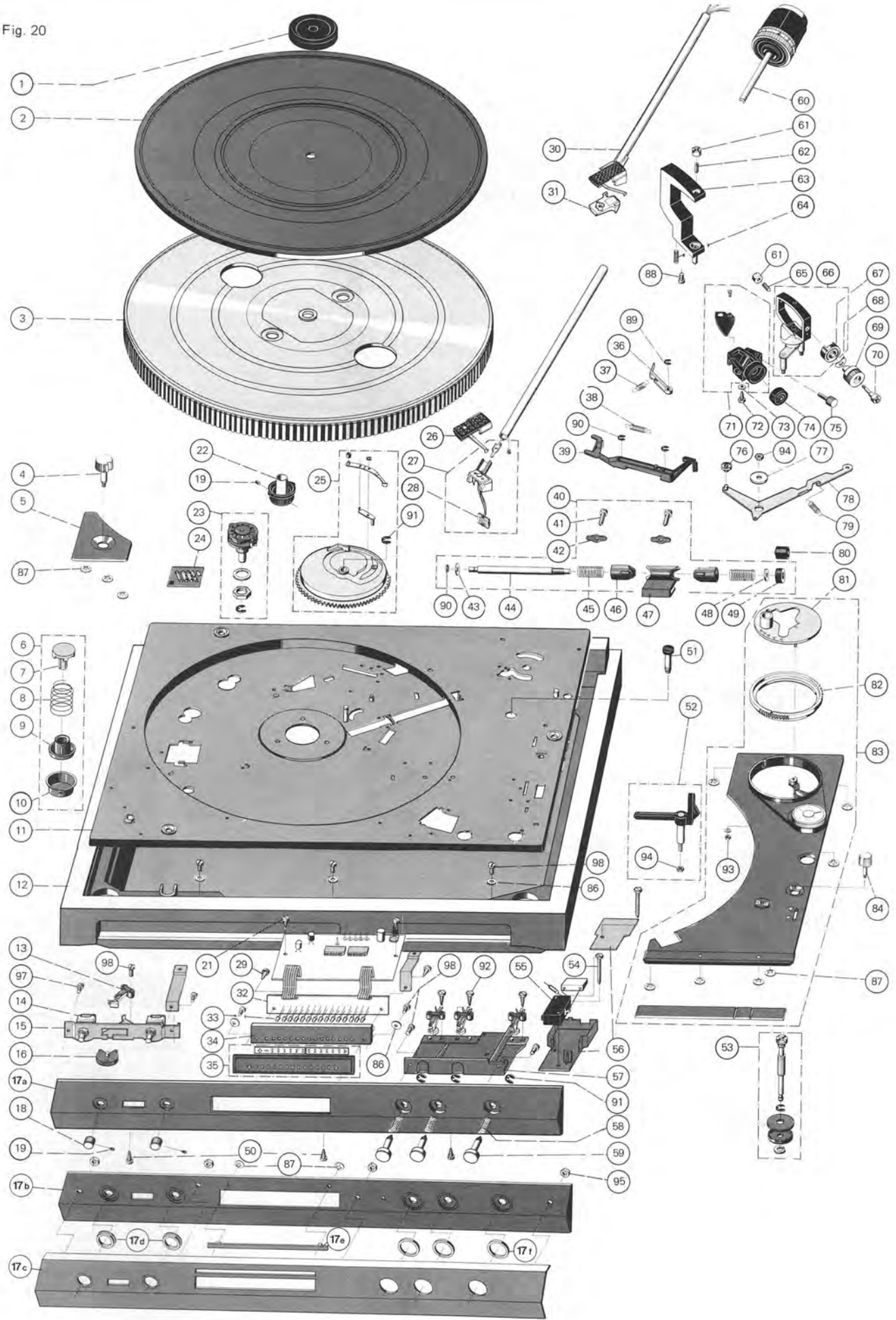
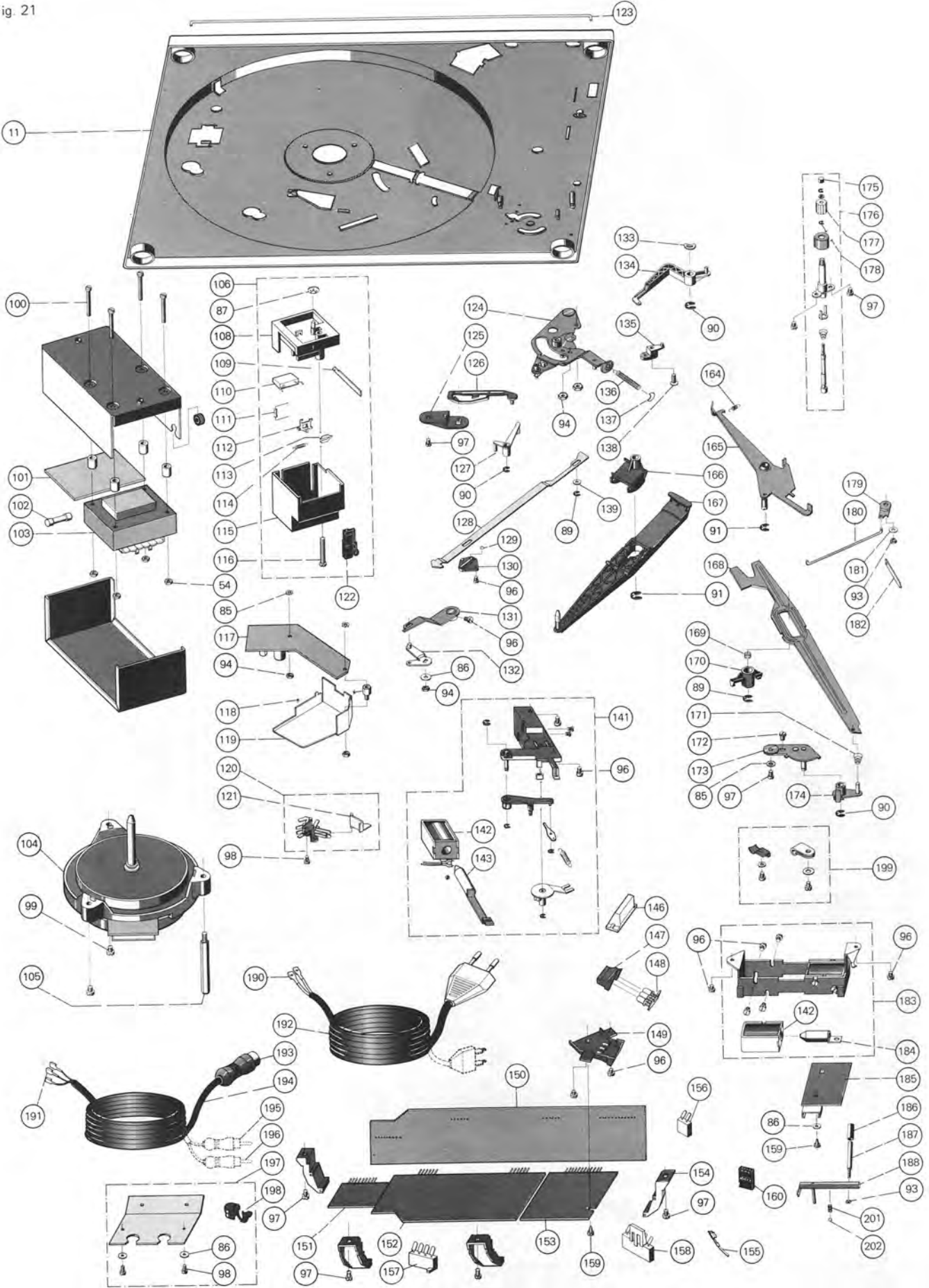

Fig. 21



Pos.	Part.-No.	Qty.	Description
130	232 104	1	Ball seat
131	242 187	1	Switch element
132	242 195	1	Switching piece
133	242 298	1	Threaded disc
134	244 331	1	Skating lever
135	239 903	1	Counter bearing
136	218 591	1	Tension spring
137	201 184	1	Setting disc
138	203 475	1	Countersunk screw
139	201 187	1	Slide disc
141	260 230	1	Magnet set-lift
142	248 266	1	Pull magnet
143	247 217	1	Armature
146	245 661	1	Stroboscope prism
147	245 648	1	Retainer piece
148	249 688	1	Diode plate
	245 235	3	Luminescence diode LD 57 CA
149	245 699	1	Stroboscope prism
150	249 689	1	Motor electronic system-base plate
151	249 690	1	Motor electronic system-module 1
152	249 691	1	Motor electronic system-module 2
153	249 692	1	Motor electronic system-module 3
154	245 662	4	Rest
155	222 038	6	Plug
156	232 342	1	Female multipoint connector 2-pole
157	229 864	1	Female multipoint connector 4-pole
158	226 514	1	Female multipoint connector 5-pole
159	210 283	1	Cheese head self-tapping screw 2.9 x 6.5
160	260 213	1	Female multipoint connector 4-pole
164	242 792	1	Tension spring
165	247 304	1	Changeover lever
166	242 789	1	Bearing block
167	246 042	1	Main lever
168	242 769	1	Adjusting bar
169	244 834	1	Compression spring
170	237 498	1	Rotary bearing
171	234 106	1	Ball spring
172	242 751	1	Eccentric pin

Pos.	Part.-No.	Qty.	Description
173	242 748	1	Adjusting plate
174	242 771	1	Rotary plate
175	216 844	1	Control stud
176	260 231	1	Lift plate cpl.
177	218 318	1	Adjusting sleeve
178	210 143	1	Securing disc 1.5
179	247 288	1	Switching angle
180	247 287	1	Switching bar
181	210 549	1	Disc 2.1
182	237 381	1	Leaf spring
183	260 323	1	Magnet set start/stop
184	247 118	2	Armature
185	260 233	1	Solenoid protective circuit
186	237 543	1	Rubber sleeve
187	247 509	1	Lever
188	247 289	1	Stroke cam
190	214 602	2	AMP connector
191	209 436	3	Flat connector sleeve
192	232 996	1	Power cable, Europe, cpl.
	232 995	1	Power cable, America, cpl.
193	209 424	1	5-pole plug
194	207 303	1	TA cable cpl.
	207 301	1	TA cable cpl. with cynch plug
195	209 425	2	Cynch plug, white
196	209 426	2	Cynch plug, black
197	246 079	1	Mounting plate
198	237 548	2	Cable conduit
199	231 079	1	Cable clips, cpl.
201	247 313	1	Compression spring
202	209 353	1	Ball $\phi 2$
***	248 166	1	Distance roll and screws for TA-mounting
***	211 379	1	Washer 2.1/5/0.5
***	245 546	1	Fillister head self-tapping screw B 2.2 x 5.2 (for TA-Removal prevention)
***	247 471	1	Operating instructions
***	247 073	1	Packing carton

Alterations reserved!

Lubricating instructions

All bearing and friction points of the unit are adequately lubricated at the factory. Replenishment of oil and grease is only necessary after approx. 2 years of normal use as the most important bearing points have sintered metal bushes. The motor bearings have long-life sintered metal bushings and thus should not be lubricated. Bearing points and friction faces should be lubricated sparingly rather than generously. When using different lubricants, chemical decomposition can often take place. To prevent lubrication failure, we recommend using the original lubricants shown below.

Fig. 22



Wacker silicon oil
AK 300 000



BP super viscostatic
10 W/40



Shell alvania No. 2

Fig. 23

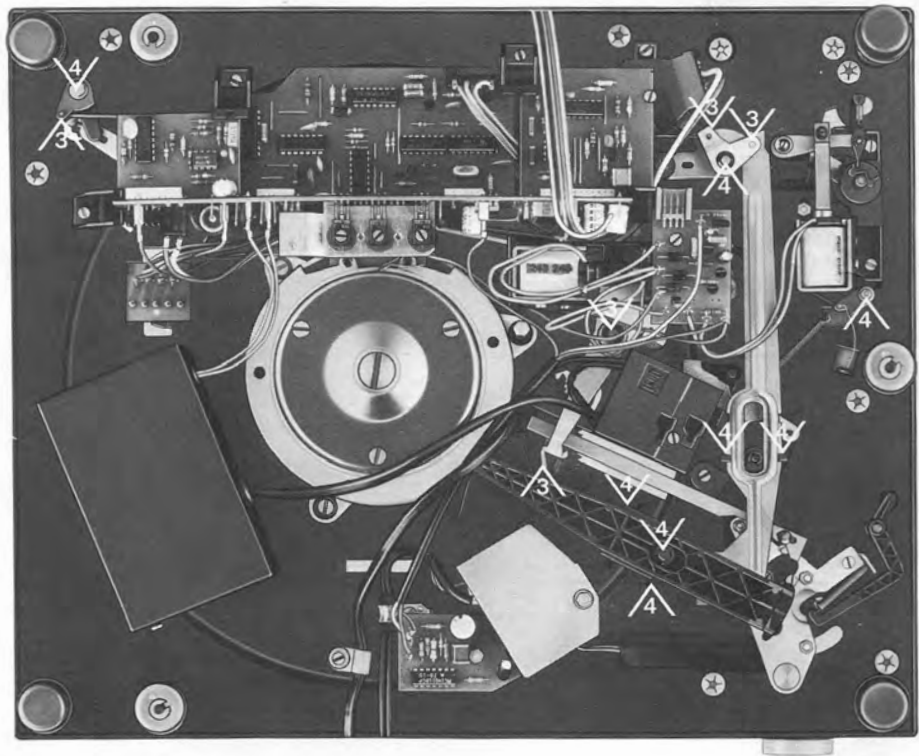

Datum-Date-Date	Zeichen-Ref.-N/réf.	Geräte Nr.-Serial number- No. de l'appareil	Gerät-Model-Appareil
11.06.79	KDT/B-fe		731 Q

Trittschall-Empfindlichkeit

Bei den ersten Modellen kamen Gewindestücke mit verkürztem Schaft zum Einsatz

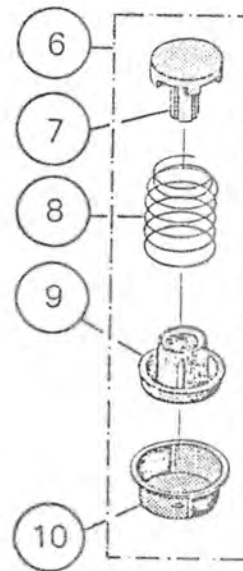

In Reklamationsfällen sind diese durch die Original-Ausführung

Art.-Nr. 230 529 (Pos. 7 - S.A. 731 Q)

zu ersetzen.



Allgemeine Information General Information Information générale

No

A 156

Datum-Date-Date 18. 12. 80	Zeichen-Ref.-N/réf. KDT / Le	Geräte Nr.-Serial number- No. de l'appareil	Gerät-Model-Appareil CS 731 Q CS 714 Q
-------------------------------	---------------------------------	--	--

See 20. 1. 81

Erscheinung:

Gleichlaufschwankungen
Motor läuft zu schnell

Ursache:

Mutterplatte Art.-Nr. 249 689

Kurzschluß zwischen Gehäuse T 9001- 9005/ BD135 and
und Kühlblech (*) durch Gratbildung Gewindebohrung M 3

Abhilfe:

Entgraten der M 3 - Gewindebohrung

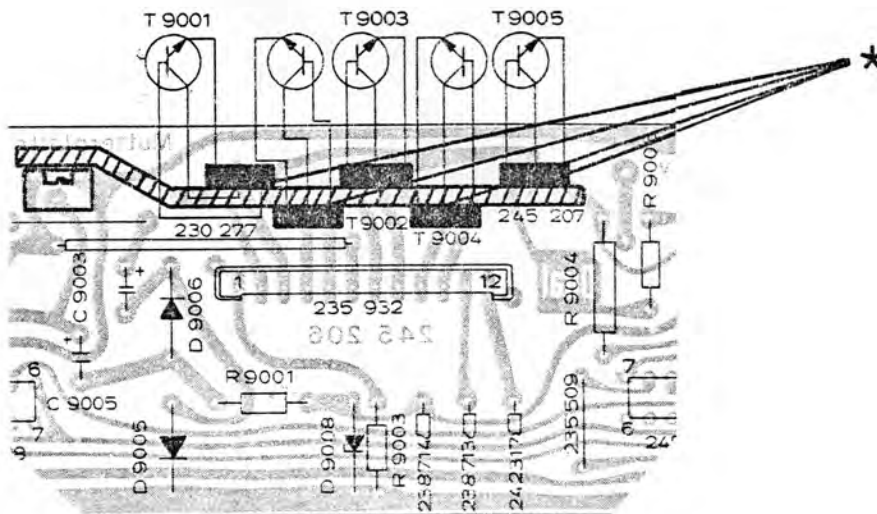

united audio

United Audio Products, Inc., 120 So. Columbus Avenue, Mt. Vernon, N.Y. 10553
(914) 664-6211 TWX-710-562-0101

September 7, 1979

PLEASE NOTE FOLLOWING CORRECTIONS TO CS-731Q
SERVICE MANUAL:

<u>Position</u>	<u>Incorrect Part #</u>	<u>Correct Part #</u>	<u>Description</u>
68	247325	261798	Securing disc, threaded
100	210517	226642	Fillister head screw M 3 x 33
151	249690	249691	Module 2
152	249691	249692	Module 3
153	249692	249690	Module 1
182	237381	237383	Leaf Spring

New Part #

194	202483	Adapter Cynch/DIN
***	247061	Accessories



Precision makes the difference in performance.