

Dual

CR 1020



Service-Anleitung Service Manual Instructions de Service

Technische Daten (typische Werte)	Technical data (typical value)	Caractéristiques techniques (valeur caractéristiques)	
HF-Teil	RF Section	Partie HF	
Empfangsbereiche FM (UKW) MW LW	Wave bands FM (VHF) MW LW	Gammes d'ondes FM (O.U.C.) P.O. G.O.	87,5– 108 MHz 522 – 1611 kHz 155 – 353 kHz
Empfindlichkeit FM-Mono (75 Ohm) FM-Stereo (75 Ohm)	Sensitivity FM-Mono (75 Ohm) FM-Stereo (75 Ohm)	Sensibilité FM-mono (75 ohms) FM-stéréo (75 ohms)	1,4 μ V 42 μ V
Pilotton-Unterdrückung 19 kHz	Pilot suppression 19 kHz	Suppression fréquence pilote 19 kHz	52 dB
Geräuschspannungsabstand (IHF) Stereo (1 kHz/46 kHz Hub)	Signal-to-noise ratio, weighted (IHF) Stereo (1 kHz/46 kHz)	Rapport signal/bruit (IHF) Stéréo (1 kHz/46 kHz)	60 dB
Klirrfaktor Stereo (1 kHz/46 kHz Hub)	Harmonic distortion Stereo (1 kHz/46 kHz)	Taux de distorsion Stéréo (1 kHz/46 kHz)	0,50 %
Übersprechdämpfung bei 1 kHz	Channel separation at 1000 Hz	Diaphonie stéréo (à 1 kHz)	35 dB
NF-Frequenzgang für Preemphasis 50 μ s – 3 dB	AF frequency response for 50 μ s pre-emphasis – 3 dB	Bande passante BF pour pré-emphasis 50 μ s à 3 dB	20 Hz–15 kHz
NF-Teil	AF Section	Partie BF	
Ausgangsleistung (DIN/8 Ω) Musikleistung Nennleistung	Rated output (DIN/8 Ω) Music power Nominal power	Puissance de sortie (DIN/8 Ω) Puissance musicale Puissance nominale	2 \times 35 Watt 2 \times 28 Watt
Klirrfaktor bei Vollaussteuerung – 3 dB, 1000 Hz	Harmonic distortion Maximum volume – 3 dB, 1000 Hz	Facteur de distorsion Volume maximum – 3 dB, 1000 Hz	< 0,09 %
Leistungsbandbreite (DIN 45500)	Power bandwidth (DIN 45500)	Réponse en puissance (DIN 45500)	20 Hz–20 kHz
Übertragungsbereich (Baß- und Höhenregler in Mittenstellung) Phono-Eingang nach RIAA	Frequency response (Bass and treble controls at center positions) Phono complying with RIAA	Bande passante (Régulateurs des basses et des aigus en position centrale) Phono selon RIAA	20 Hz–20 kHz \pm 2 dB 30 Hz–18 kHz \pm 2 dB
Eingänge Tape/Cd Phono	Inputs Tape/Cd Phono	Entrées Tape/Cd Phono	200 mV, 47 k Ω 3 mV, 47 k Ω
Ausgänge Druckklemmen für ein Lautsprecher-Paar, 1 Koaxial-Buchse 1/4 inch für Kopfhörer 1 Line-Ausgang an Tape/Cd (R _i = 470 Ω)	Outputs Press-type terminal strips for one set of speakers, 1 coaxial jack 1/4 inch for headphone 1 Line output to Tape/Cd (R _i = 470 Ω)	Sorties Barres a ressort pour de hauts- parleurs, 1 prise coaxiale de 1/4 inch pour le raccordement du casque-écouter 1 sortie Line sur la prise Tape/Cd (R _i = 470 Ω)	8–16 Ohm
Geräuschspannung gemessen nach IHF bewertet mit A-Filter (RMS) bezogen auf Nennleistung	Noise voltage measured in accordance with IHF weighted with A-filter (RMS) in relation to rated power	Tension perturbatrice mesurée selon IHF pondérée avec filtre A (RMS), ramenée à la puissance nominale	
Tape/Cd Phono	Tape/Cd Phono	Tape/Cd Phono	80 dB 65 dB
Übersprechdämpfung bei 1000 Hz zwischen den Kanälen zwischen den Eingängen	Crosstalk attenuation at 1000 Hz between the channels between the inputs	Affaiblissement de diaphonie pour 1000 Hz entre les canaux entre les entrées	60 dB 65 dB
Leistungsaufnahme (maximal)	Power consumption (maximum)	Puissance absorbée (maximale)	230 Watt
Netzspannung	Line voltage	Tension du réseau	230 Volt

Dual GmbH · Postfach 1144 · 7742 St. Georgen/Schwarzwald

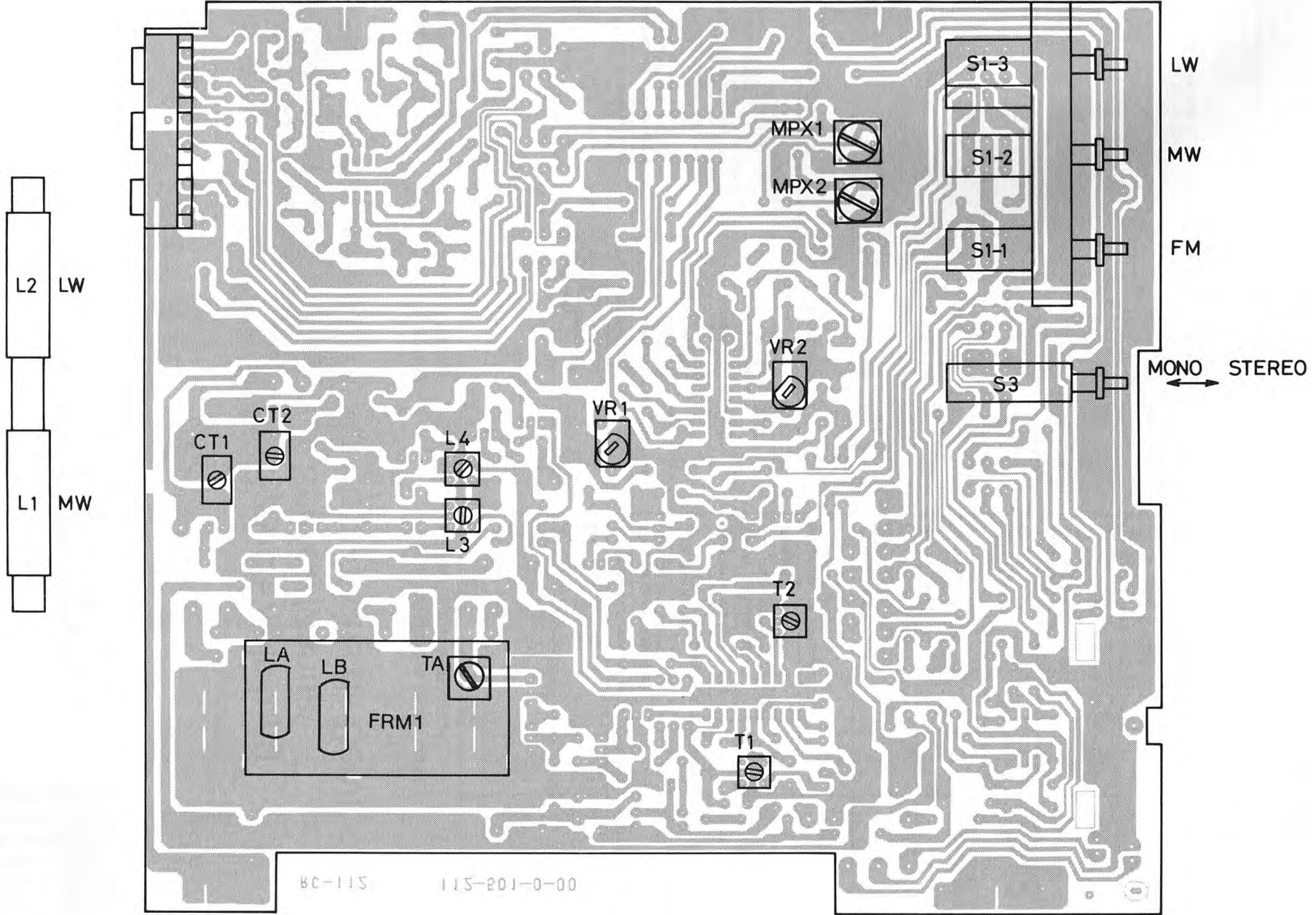

Abgleichanleitung CR 1020

Signalquelle	Einstellung Gerät	Einstellung Signalquelle	Meßgerät Anschluß	Abgleichposition	Abgleich, Bemerkung	
FM-ZF, Vorkreis						
FM-Meßsender an 75 Ohm Antenneneingang	Senderfreie Frequenz ca. 100 MHz	0-10 mV Hub \pm 40 kHz Mod. 1 kHz ca. 100 MHz auf Deckung	NF-Voltmeter Oszilloskop über 8 Ohm Lastwiderstand an Lautsprecher- ausgang	TA, T 2	Maximum	
	ca. 88 MHz	ca. 88 MHz auf Deckung		LA, LB		
	ca. 108 MHz	ca. 108 MHz auf Deckung			Kontrolle	
FM-ZF-Feinabgleich						
Antenne an 75 Ohm Antenneneingang	Starken FM-Sender auf seiner Sollfrequenz empfangen			T 2	Bei \pm 50 kHz (UP, DOWN) dürfen TUNING und SIGNAL-LED's nicht leuchten	
Decoderabgleich						
FM-Meßsender an 75 Ohm Antenneneingang	Senderfreie Frequenz ca. 100 MHz	ca. 100 MHz auf Deckung 1-2 mV, Pilot aus	Frequenzzähler an Pin 9 IC 2	VR 1	19 kHz \pm 0,05 kHz	
		ca. 100 MHz auf Deckung 1-2 mV, 19 kHz, Pilot ein Hub \pm 40 kHz Mod. 1 kHz Abwechs. L oder R Kanal	NF-Voltmeter Oszilloskop über 8 Ohm Lastwiderstand an Lautsprecher- ausgang	VR 2	auf größte Kanaltrennung	
Unterdrückung Pilottonreste 19 kHz						
FM-Meßsender an 75 Ohm Antenneneingang	Senderfreie Frequenz ca. 100 MHz	ca. 100 MHz auf Deckung 1-2 mV 19 kHz Pilot ein	NF-Voltmeter Oszilloskop über 8 Ohm Lastwiderstand an Lautsprecher- ausgang	MPX 1 (l.K) MPX 2 (r.K)	Minimum	
AM-ZF, Vorkreis						
AM-Meßsender an 75 Ohm Antenneneingang	Ferritantenne ausklappen MW: Ein 999 kHz	10 μ V-1 mV, 1 kHz Mod. 30 % 999 kHz	NF-Voltmeter Oszilloskop über 8 Ohm Lastwiderstand an Lautsprecher- ausgang	T 1	Maximum	
		612 kHz		612 kHz		L 1, L 3
		1404 kHz		1404 kHz		CT 1
		LW: Ein 164 kHz		164 kHz		L 2, L 4
		335 kHz		335 kHz		CT 2

Alignment instruction CR 1020

Signal source	Unit adjustment	Signal source adjustment	Testgear connection	Alignment position	Alignment
FM-IF-aerial circuit					
FM-generator to 75 ohms FM-antenna input	Transmitting free frequency approx. 100 MHz	0-10 mV Dev. \pm 40 kHz Mod. 1 kHz tune to approx. 100 MHz	AF-voltmeter Oscilloscope via 8 ohms loading-resistor to speaker output	TA, T 2	Maximum
	approx. 88 MHz	tune to approx. 88 MHz		LA, LB	
	approx. 108 MHz	tune to approx. 108 MHz			Chek
FM-IF-vernier alignment					
Antenna to 75 ohms antenna input	tune noise free station to nom. transmitting frequency			T 2	at \pm 50 kHz (up, down) TUNING and SIGNAL-LED's must not light up
Decoder-alignment					
FM-generator to 75 ohms FM-antenna input	Transmitting-free frequency approx. 100 MHz	tune to approx. 100 MHz without pilotton 1-2 mV	frequency counter to pin 9, IC 2	VR 1	19 kHz \pm 0,05 kHz
		tune to approx. 100 MHz 1-2 mV, 19 kHz, Pilot on Dev. \pm 40 kHz Mod. 1 kHz only left or right channel	AF-voltmeter Oscilloscope via 8 ohms loading-resistor to speaker output	VR 2	Channel separation to Maximum
Pilot-suppression 19 kHz					
FM-generator to 75 ohms FM-antenna input	Transmitting-free frequency approx. 100 MHz	tune to approx. 100 MHz 1-2 mV 19 kHz, Pilot on	AF-voltmeter Oscilloscope via 8 ohms loading-resistor to speaker output	MPX 1 (l.K.) MPX 2 (r.K.)	Minimum
AM-IF-aerial circuit					
AM-generator to 75 ohms AM-antenna input	swing out the ferrit antenna MW: on 999 kHz	10 μ V-1 mV, 1 kHz Mod. 30% 999 kHz	AF-voltmeter Oscilloscope via 8 ohms loading-resistor to speaker output	T 1	Maximum
	612 kHz	612 kHz		L 1, L 3	
	1404 kHz	1404 kHz		CT 1	
	LW: on 164 kHz	164 kHz		L 2, L 4	
	335 kHz	335 kHz		CT 2	

LED-platte/LED board/Plaque de LED **L**

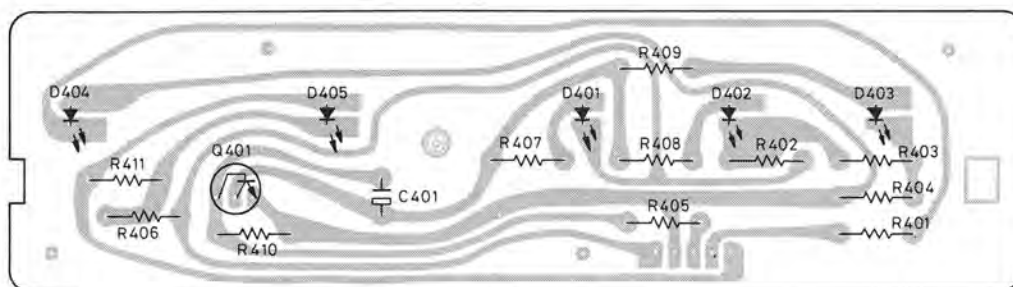

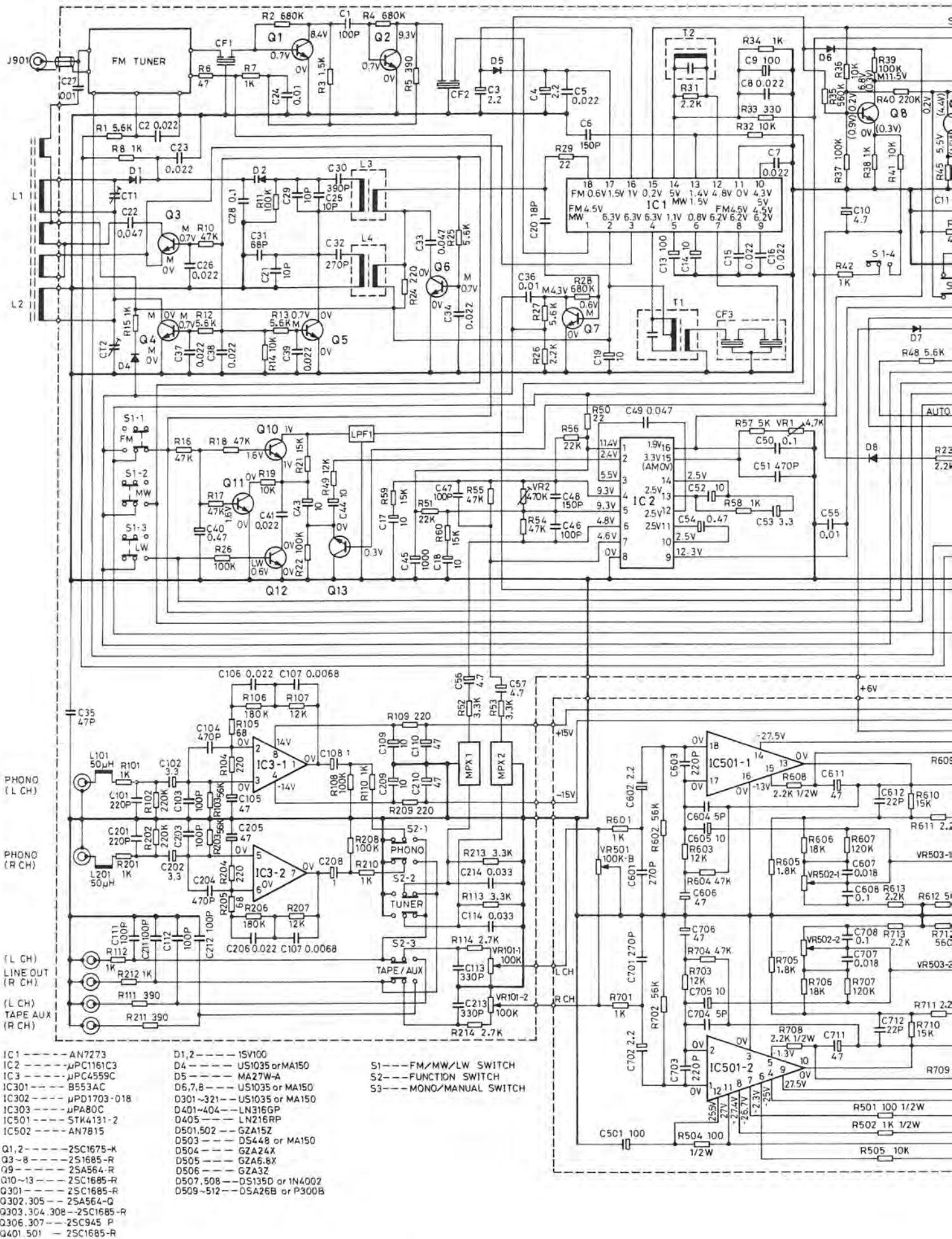

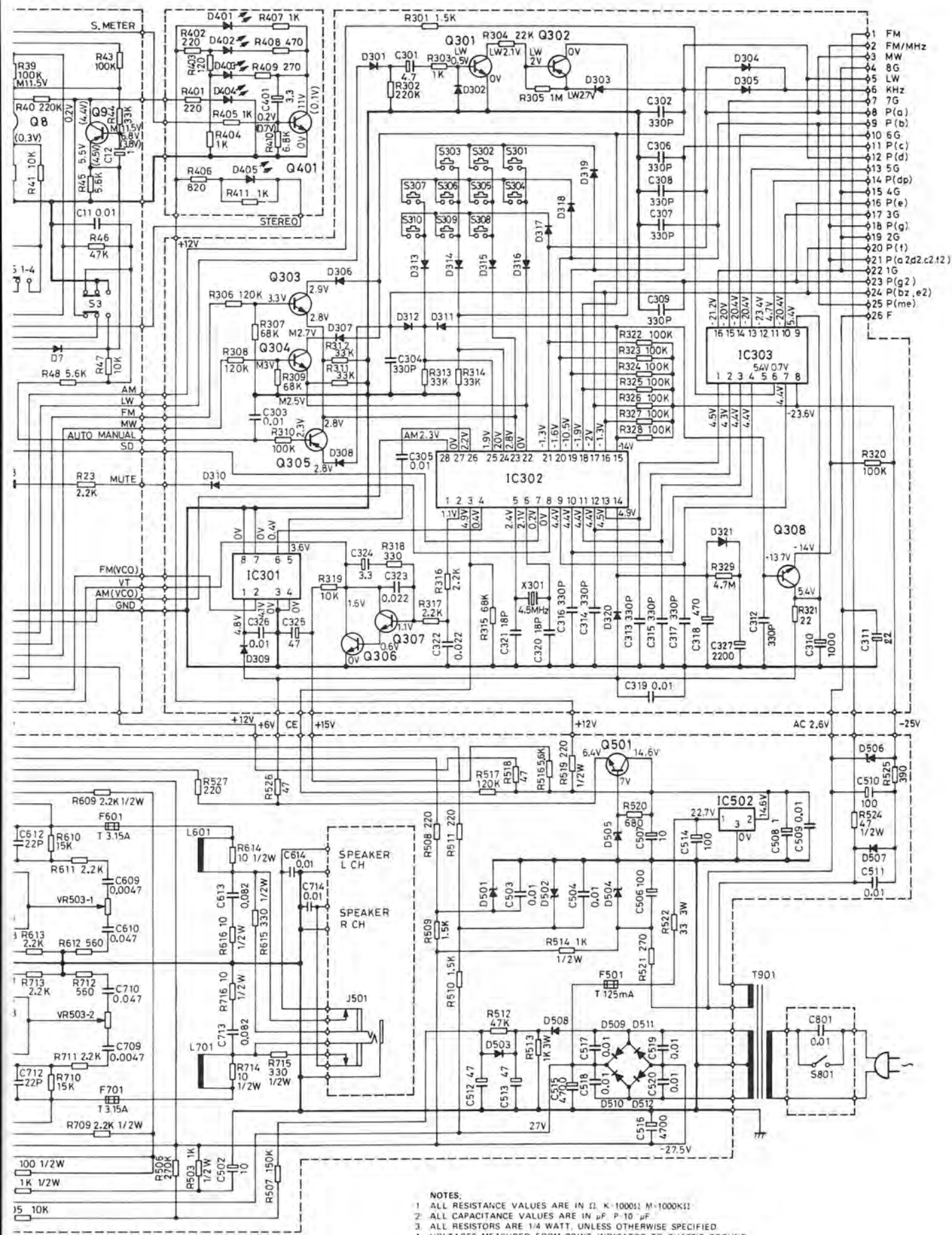

NOTES:
 1 ALL RESISTANCE VALUES ARE IN Ω , K, 1000 Ω , M-1000K Ω !
 2 ALL CAPACITANCE VALUES ARE IN μ F, P, 10 μ F
 3 ALL RESISTORS ARE 1/4 WATT, UNLESS OTHERWISE SPECIFIED
 4 VOLTAGES MEASURED FROM POINT INDICATOR TO CHASSIS GROUND WITH V.T.V.M. AT LINE VOLUME CONTROL MINIMUM AND NO SIGNAL
 (SPECIFICATIONS AND CIRCUITS SUBJECT TO CHANGE WITHOUT NOTICE FOR IMPROVEMENT)

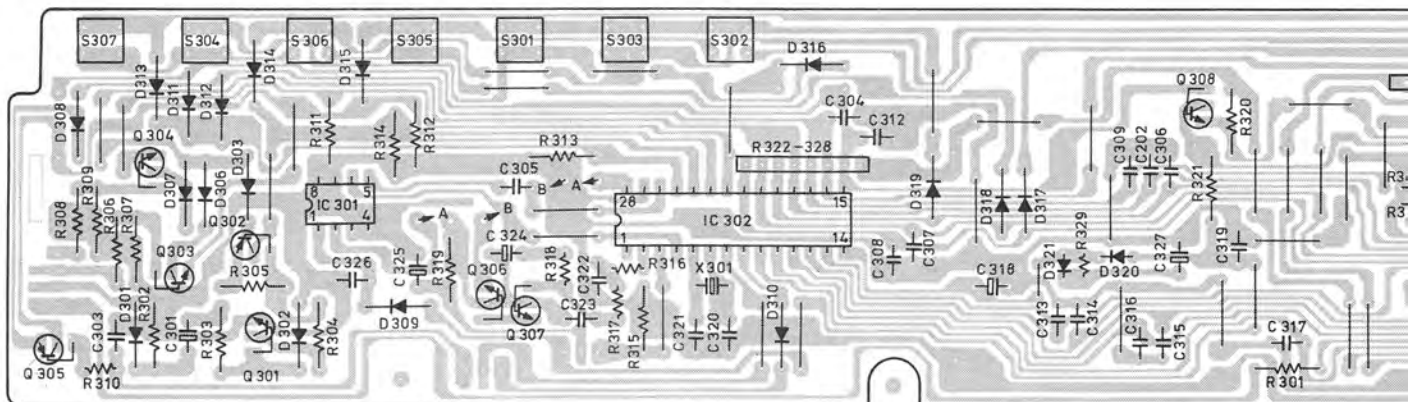
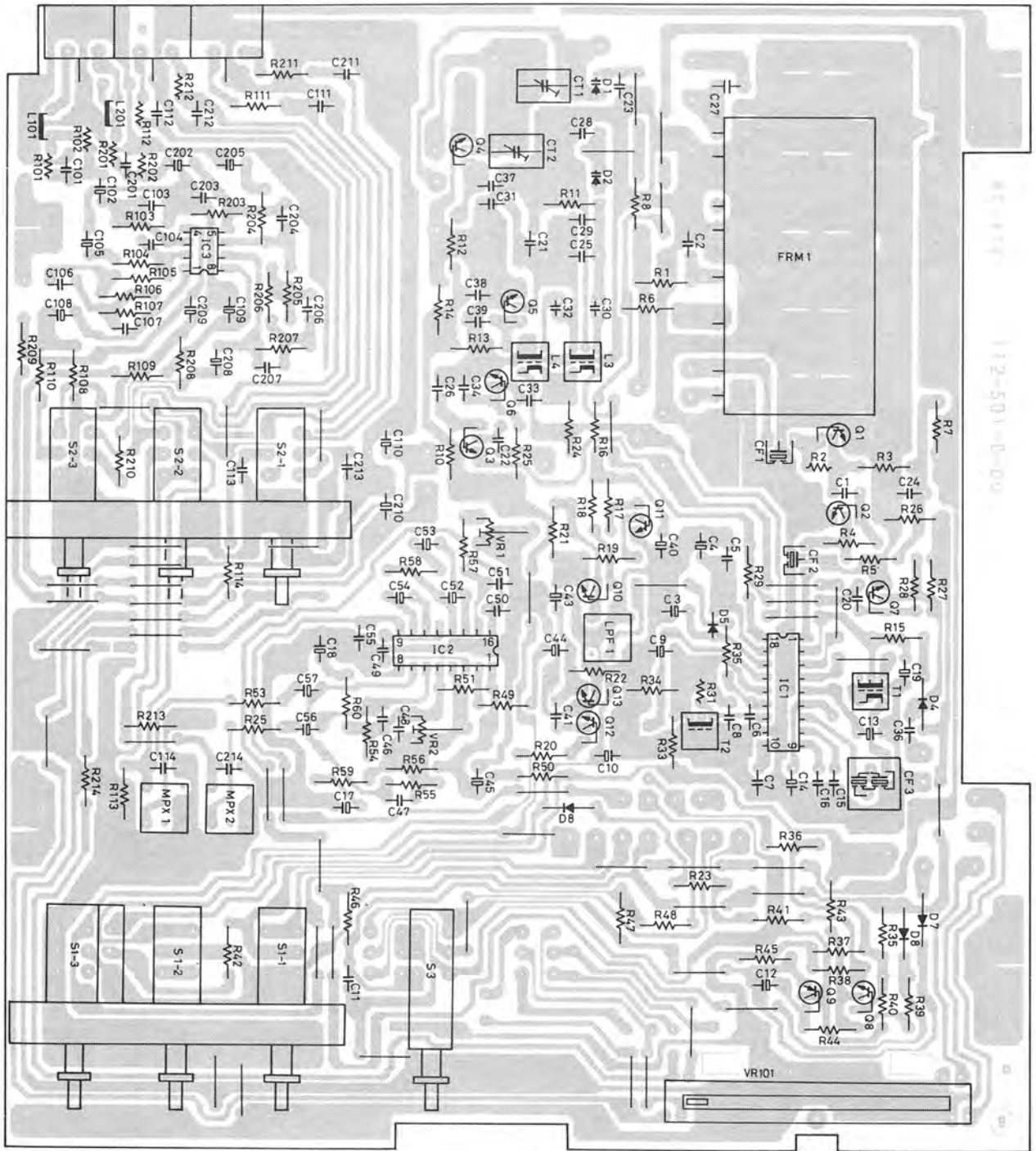

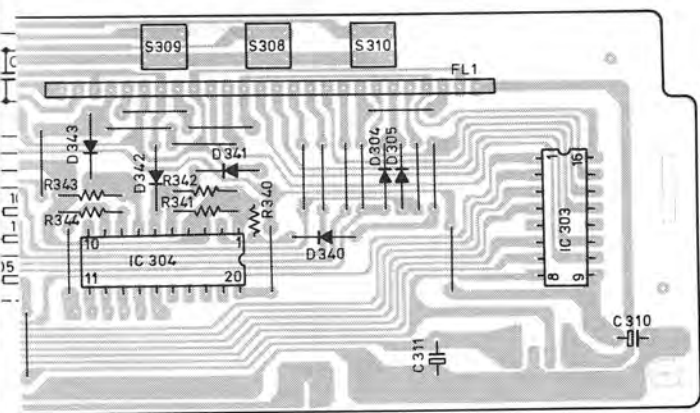
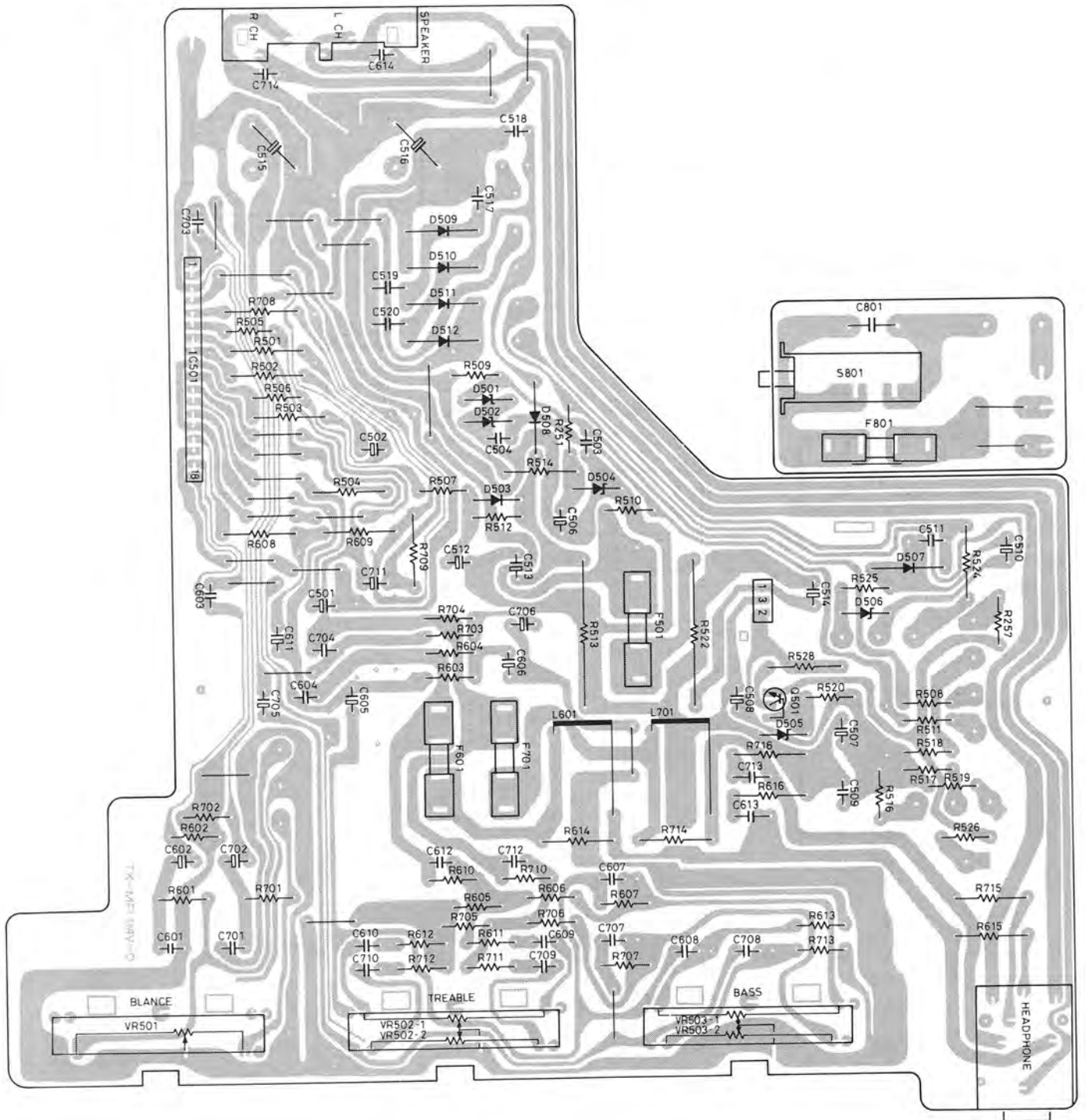

B = Bestückungsseite/Equipment side/Côté de composants

L = Leiterseite/Wiring side/Côté de conducteur

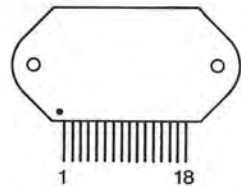
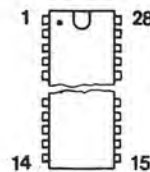
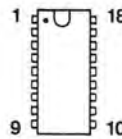
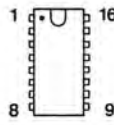
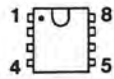
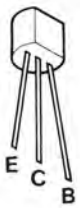
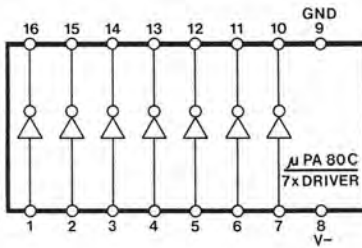
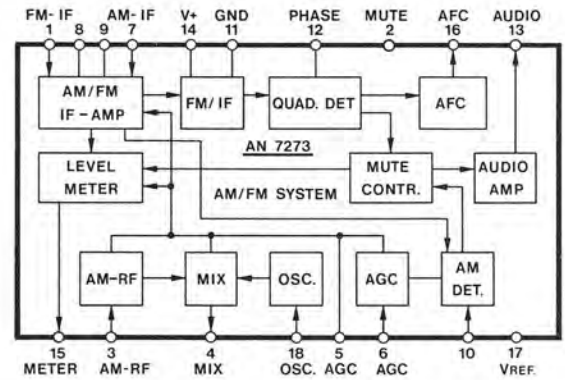
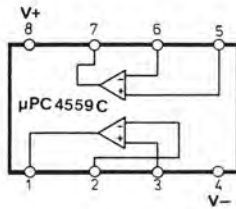
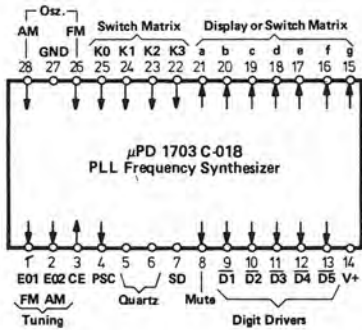
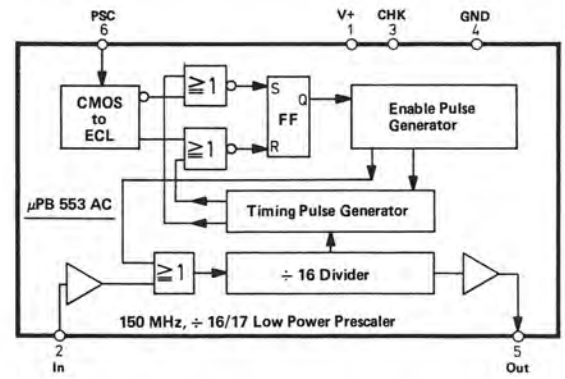
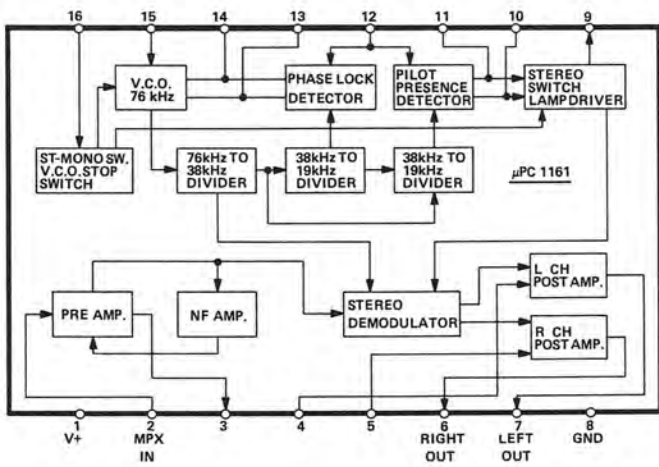

- 2 SC 1675-K
- 2 SC 1685-R
- 2 SC 945-P
- 2 SA 564-R
- 2 SA 569-Q

AN 78 M 24

μPC 4559 C
μPB 553 AC

μPA 80 C
μPC 1161 C 3

AN 7273

μPD 1703 C-018

STK 4131-2

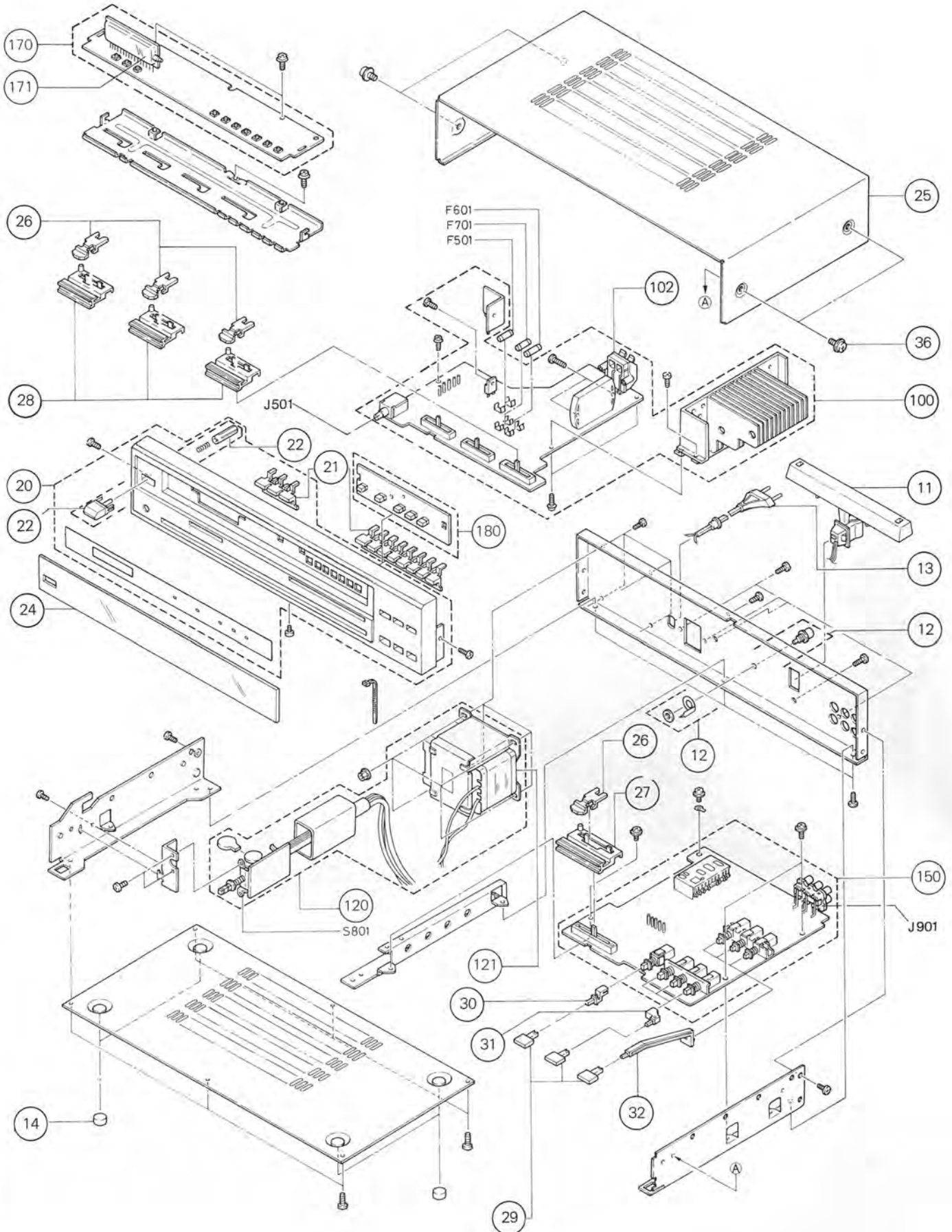

Ersatzteile · Replacement parts · Pièces détachées · CR 1020

Pos.	Art.-Nr.	Stck	Bezeichnung
11	277 825	1	Ferritantenne
12	277 834	1	Antennenbuchse
13	243 750	1	Netzkabel Europa
14	278 265	1	Gerätefuß
20	277 824	1	Frontblende kpl.
21	277 864	1	Tastenkнопf (Sendereinstellung)
22	278 271	1	Taste kpl. (power)
24	277 827	1	Frontabdeckung
25	277 828	1	Gehäuseblech
26	277 829	4	Knopf (bass – volume)
27	278 266	1	Support
28	278 267	3	Support B
29	277 830	7	Taste (function, mode)
30	278 268	1	Tastenverlängerung A
31	278 269	3	Tastenverlängerung B
32	278 270	3	Tastenverlängerung C
36	272 673	4	Schraube B 4 x 6
100	277 835	1	Netzplatte kpl.
102	277 843	1	Lautsprecherklemmen
D 501	277 851	2	Diode GZA 15 Z
D 502	277 851	2	Diode GZA 15 Z
D 503	277 855	1	Diode DS 448
D 504	277 852	1	Diode GZA 24 X
D 505	277 850	1	Diode GZA 6,8 X
D 506	277 849	1	Diode GZA 3 Z
D 507	278 026	2	Gleichrichter DS 135 D
D 508	278 026	2	Gleichrichter DS 135 D
D 509	277 853	4	Gleichrichter DSA 26 B
D 510	277 853	4	Gleichrichter DSA 26 B
D 511	277 853	4	Gleichrichter DSA 26 B
D 512	277 853	4	Gleichrichter DSA 26 B
F 501	209 719	1	Sicherung 0,125 A/250 V T
F 601	263 701	2	Sicherung 3,15 A/250 V T
F 701	263 701	2	Sicherung 3,15 A/250 V T
L 601	277 838	2	Spule
L 701	277 838	2	Spule
Q 501	277 844	1	Transistor 2 SC 1685 R
IC 501	277 846	1	IC STK 4131 II
IC 502	277 845	1	IC AN 7815
J 501	277 841	1	Kopfhörerbuchse
VR 501	277 839	1	Steller 100 kΩ (balance)
VR 502	277 840	2	Steller 100 kΩ (treble)
VR 503	277 840	2	Steller 100 kΩ (bass)
120	277 836	1	Netzteil kpl.
121	277 856	1	Netztrafo
S 801	271 004	1	Druckschalter (power)
150	277 821	1	Tunerplatte
D 1	277 872	2	Diode 1 SV 100
D 2	277 872	2	Diode 1 SV 100
D 4	271 099	4	Diode US 1035
D 5	277 871	1	Diode MA 27 W-A
D 6	271 099	4	Diode US 1035
D 7	271 099	4	Diode US 1035
D 8	271 099	4	Diode US 1035
J 901	277 991	1	Cinchbuchsen 3-fach
L 3	277 876	1	Spule
L 4	277 877	1	Spule
L 101	277 873	2	Spule
L 201	277 873	2	Spule
Q 1	277 868	2	Transistor 2 SC 1675 K

Pos.	Art.-Nr.	Stck	Bezeichnung
Q 2	277 868	2	Transistor 2 SC 1675 K
Q 3	277 844	10	Transistor 2 SC 1685 R
bis			
Q 8	277 844	10	Transistor 2 SC 1685 R
Q 9	265 578	1	Transistor 2 SA 5 64
Q 10	277 844	10	Transistor 2 SC 1685 R
Q 11	277 844	10	Transistor 2 SC 1685 R
Q 12	277 844	10	Transistor 2 SC 1685 R
Q 13	277 844	10	Transistor 2 SC 1685 R
S 1	277 881	1	Schalter (tuner mode)
S 2	277 882	1	Schalter (function)
S 3	277 883	1	Schalter (mono/manual)
T 1	277 875	1	Spule
T 2	277 990	1	Spule
CF 1	277 886	2	Keramikfilter
CF 2	277 886	2	Keramikfilter
CF 3	277 887	1	Keramikfilter
CT 1	277 878	2	Trimmer
CT 2	277 878	2	Trimmer
FM 1	277 884	1	UKW-Teil
IC 1	277 870	1	IC AN 7273
IC 2	277 869	1	IC μPC 1161 C 3
IC 3	236 299	1	IC RC 4558 D
LF 1	277 888	1	Low Pass Filter
MX 1	277 885	2	MPX Filter
MX 2	277 885	2	MPX Filter
VR 1	270 193	1	Steller 5 kΩ
VR 2	277 880	1	Steller 4,7 kΩ
VR 101	277 879	1	Steller 100 kΩ (volume)
170	277 822	1	Controllplatte
D 301	271 099	21	Diode US 1035
D 321	271 099	21	Diode US 1035
Q 301	277 844	4	Transistor 2 SC 1685 R
Q 302	265 578	2	Transistor 2 SA 564
Q 303	277 844	4	Transistor 2 SC 1685 R
Q 304	277 844	4	Transistor 2 SC 1685 R
Q 305	265 578	2	Transistor 2 SA 564
Q 306	275 260	2	Transistor 2 SC 945 P
Q 307	275 260	2	Transistor 2 SC 945 P
Q 308	277 844	4	Transistor 2 SC 1685 R
S 301	277 857	10	Taster (Sendereinstellung)
bis			
S 310	277 857	10	Taster (Sendereinstellung)
X 301	277 858	1	Keramikfilter
FL 1	277 859	1	Display
IC 301	277 862	1	IC μP B 553 AC
IC 302	277 860	1	IC μP D 1703 C 018
IC 303	277 861	1	IC μP A 80 C
180	277 823	1	LED-Platte
D 401	277 867	4	LED LN 316 GP grün
D 402	277 867	4	LED LN 316 GP grün
D 403	277 867	4	LED LN 316 GP grün
D 404	277 867	4	LED LN 316 GP grün
D 405	277 866	1	LED LN 216 RP rot
Q 401	277 844	1	Transistor 2 SC 1685 R
	275 472	1	Bedienungsanleitung
	277 833	1	Verpackungskarton
	277 832	1	Seitenteil R (Verpackung)
	277 831	1	Seitenteil L (Verpackung)

Änderungen vorbehalten!
Subject to change!
Sous réserve de modification!

