

# Dual

## Service-Anleitung Service Manual Instructions de Service

# CT 7065

# #39018

Download from www.dual.de  
Not for commercial use



Technische Daten (typische Werte)	Specifications (typical values)	Caractéristiques techniques (valeurs types)	Dati tecnici (valori tipici)	
<b>Empfangsbereiche</b> FM (UKW) AM (MW) AM (LW)	<b>Reception wavebands</b> FM (VHF) AM (MW) AM (LW)	<b>Games de fréquences</b> FM (OC) AM (PO) AM (GO)	<b>Campi di ricezione</b> FM (OUC) AM (onde medie) AM (onde lunghe)	87– 108 MHz 522–1611 kHz 153– 279 kHz
<b>Empfindlichkeit</b> (an 75 Ω) FM – Mono (26 dB) FM – Stereo (46 dB)	<b>Sensitivity</b> (at 75 Ω) FM – mono (26 dB) FM – stereo (46 dB)	<b>Sensibilité</b> (à 75 ohms) FM – Mono (26 dB) FM – Stéréo (46 dB)	<b>Sensibilità</b> (su 75 ohm) FM – mono (26 dB) FM – stereo (46 dB)	0,9 μV 30 μV
<b>Trennschärfe</b> FM stat./dyn.	<b>FM selectivity</b> stat./dyn.	<b>Sélectivité</b> FM stat./dyn.	<b>Selettività</b> FM stat./din.	80/70 dB
<b>Geräuschspannungsabstand</b>	<b>Signal/noise ratio</b>	<b>Rapport signal/bruit</b>	<b>Rapporto segnale disturbo</b>	70 dB
<b>Netzspannung</b> Model Europa Model USA/Kanada	<b>Mains voltage</b> European model US/Canadian model	<b>Voltage secteur</b> Modèle Europe Modèle USA/Canada	<b>Tensione di rete</b> modello Europa modello Stati Uniti/Canada	230 V/50 Hz 120 V/60 Hz
<b>Maße</b> (Breite × Höhe × Tiefe)	<b>Dimensions</b> (width × height × depth)	<b>Dimensions</b> (largeur × hauteur × profondeur)	<b>Dimensioni</b> (larghezza × altezza × profondità)	440 × 82 × 245 mm

Dual GmbH · Postfach 1144 · 7742 St. Georgen/Schwarzwald

## Abgleichanleitung

Signalquelle	Einstellung Gerät	Einstellung Signalquelle	Meßgerät Anschluß	Abgleichposition	Abgleich, Bemerkung
<b>FM-Oszillator</b>					
	108 MHz		DC Voltmeter an TP 1	L 16	8,3 V DC $\pm$ 0,2 V
	87,5 MHz				Kontrolle: 2,0–2,5 V DC
<b>FM-ZF Vorkreis</b>					
FM-Meßsender an 75 Ohm Antenneneingang	Senderfreie Frequenz  ca. 98 MHz	0–1 mV Hub $\pm$ 40 kHz Mod. 1 kHz ca. 98 MHz auf Deckung	Klirrfaktormeßbrücke Oszilloskop an NF-Ausgang	T 101	NF-Maximum
				T 102	
	T 103	NF und Klirrfaktor Minimum			
	L 1/L 2, L 3/L 4, L 5	NF-Maximum			
105 MHz	ca. 105 MHz auf Deckung		TC 1, TC 2, TC 3		
				Vorkreisabgleich wiederholen	
<b>FM-ZF (Feinabgleich)</b>					
Antenne an 75 Ohm Antenneneingang	Starken FM-Sender auf seiner Sollfrequenz empfangen		DC-Voltmeter an: TP 2–TP 3	T 103	DC-Maximum und DC-Minimum ermitteln
				T 103	Spannungsmittel einstellen
				T 102	0 V $\pm$ 1 mV DC
				Abgleich wiederholen	
<b>Pilotfrequenz 76 kHz, Kanaltrennung</b>					
FM-Meßsender an 75 Ohm Antenneneingang	Senderfreie Frequenz ca. 98 MHz HI-Blend-Taste: Aus	ca. 98 MHz auf Deckung Hub $\pm$ 40 kHz, Mod. 1 kHz 1–2 mV, ohne Pilotton	Frequenzzähler an TP 5	VR 301	76 kHz $\pm$ 50 Hz
		mit 19 kHz Pilot	NF-Voltmeter, Oszilloskop an NF-Ausgang	VR 302	Maximale Kanaltrennung
<b>Unterdrückung Pilottonreste (19 kHz)</b>					
FM-Meßsender an 75 Ohm Antenneneingang	Senderfreie Frequenz ca. 98 MHz	Senderfreie Frequenz ca. 98 MHz auf Deckung 1–2 mV, 19 kHz, Pilot ein	NF-Voltmeter Oszilloskop an NF-Ausgang	T 302 (l.K)	Minimum
				T 301 (r.K)	
<b>Suchlaufschwelle, FM-Signalanzeige</b>					
FM-Meßsender an 75 Ohm Antenneneingang	Senderfreie Frequenz ca. 98 MHz	ca. 98 MHz auf Deckung Hub $\pm$ 40 kHz, Mod 1 kHz 10 $\mu$ V	Kontrolle am Display	VR 101	„TUNED“ Anzeige muß aufleuchten
				VR 102	Achter Signalbalken muß aufleuchten
<b>AM-Oszillator</b>					
	522 kHz		DC-Voltmeter an TP 1	T 201	0,65 V DC $\pm$ 0,05 V
	1611 kHz			TC 203	9,0 V DC $\pm$ 0,4 V
	153 kHz			T 202	1,6 V DC $\pm$ 0,05 V
	279 kHz			TC 204	5,4 V DC $\pm$ 0,4 V
<b>AM-ZF Vorkreis</b>					
AM-Meßsender an 75 Ohm Antenneneingang	999 kHz	20 $\mu$ V–1 mV, 1 kHz, Mod. 30 % 999 kHz	NF-Voltmeter Oszilloskop an NF-Ausgang	T 203, T 204	Maximum
	594 kHz	594 kHz		MW Ferritantenne	
	1404 kHz	1404 kHz		TC 201	
	162 kHz	162 kHz		LW Ferritantenne	
	252 kHz	252 kHz		TC 202	
<b>AM-Signalanzeige</b>					
AM-Meßsender an 75 Ohm Antenneneingang	999 kHz	100 $\mu$ V, 1 kHz Mod. 30 % 999 kHz	Kontrolle am Display	VR 201	Achter Signalbalken muß aufleuchten

## Tuning Instructions

Signal source	Equipment setting	Signal source setting	Connection of measuring instrument	Item to be tuned	Tuning, Remarks
<b>FM oscillator</b>					
	108 MHz		DC voltmeter to TP 1	L 16	8.3 V DC $\pm$ 0.2 V
	87.5 MHz				
<b>FM IF, input circuit</b>					
FM signal generator to 75-ohm antenna input	Frequency without transmitters approx. 98 MHz	0 - 1 mV, Shift $\pm$ 40 kHz, Mod. 1 kHz, Tune to approx. 98 MHz	Harmonic detector oscilloscope to AF output	T 101	AF maximum
				T 102	
	90 MHz	Tune to approx. 90 MHz		L 1/L 2, L 3/L 4, L 5	AF maximum
	105 MHz	Tune to approx. 105 MHz		TC 1, TC 2, TC 3	
				Repeat input-circuit tuning	
<b>FM IF (fine tuning)</b>					
Antenna to 75-ohm antenna input	Receive strong FM transmitter at its nominal frequency		DC voltmeter to: TP 2 - TP 3	T 103	Determine DC maximum and DC minimum
				T 103	Adjust power mean
				T 102	0 V $\pm$ 1 mV DC
				Repeat tuning	
<b>Pilot frequency 76 kHz, channel separation</b>					
FM signal generator to 75-ohm antenna input	Frequency without transmitters approx. 98 MHz Waveguide shutter key: OFF	Tune to approx. 98 MHz, Shift $\pm$ 40 kHz, Mod. 1 kHz, 1 - 2 mV, without pilot tone	Frequency counter to TP 5	VR 301	76 kHz $\pm$ 50 Hz
		with 19-kHz pilot	AF voltmeter, oscilloscope to AF output	VR 302	Maximum channel separation
<b>Suppression of residual pilot frequencies (19 kHz)</b>					
FM signal generator to 75-ohm antenna input	Frequency without transmitters approx. 98 MHz	Frequency without transmitters Tune to approx. 98 MHz 1 - 2 mV, 19-kHz pilot ON	AF voltmeter, oscilloscope to AF output	T 302 (left channel)	Minimum
				T 301 (right channel)	
<b>Search threshold, FM signal indicator</b>					
FM signal generator to 75-ohm antenna input	Frequency without transmitters approx. 98 MHz	Tune to approx. 98 MHz, Shift $\pm$ 40 kHz, Mod. 1 kHz 10 $\mu$ V	Check the display	VR 101	"TUNED" display must light up
				VR 102	Eighth signal bar must light up
<b>AM oscillator</b>					
	522 kHz		DC voltmeter to TP 1	T 201	0.65 V DC $\pm$ 0.05 V
	1611 kHz			TC 203	9.0 V DC $\pm$ 0.4 V
	153 kHz			T 202	1.6 V DC $\pm$ 0.05 V
	279 kHz			TC 204	5.4 V DC $\pm$ 0.4 V
<b>AM IF, input circuit</b>					
AM signal generator to 75-ohm antenna input	999 kHz	20 $\mu$ V - 1 mV, 1 kHz Mod. 30% 999 kHz	AT voltmeter, oscilloscope to AF output	T 203, T 204	Maximum
	594 kHz	594 kHz		AM ferrite-rod antenna	
	1404 kHz	1404 kHz		TC 201	
	162 kHz	162 kHz		LW ferrite-rod antenna	
	252 kHz	252 kHz		TC 202	
<b>AM signal indicator</b>					
AM signal generator to 75-ohm antenna input	999 kHz	100 $\mu$ V, 1 kHz Mod. 30% 999 kHz	Check the display	VR 201	Eighth signal bar must light up

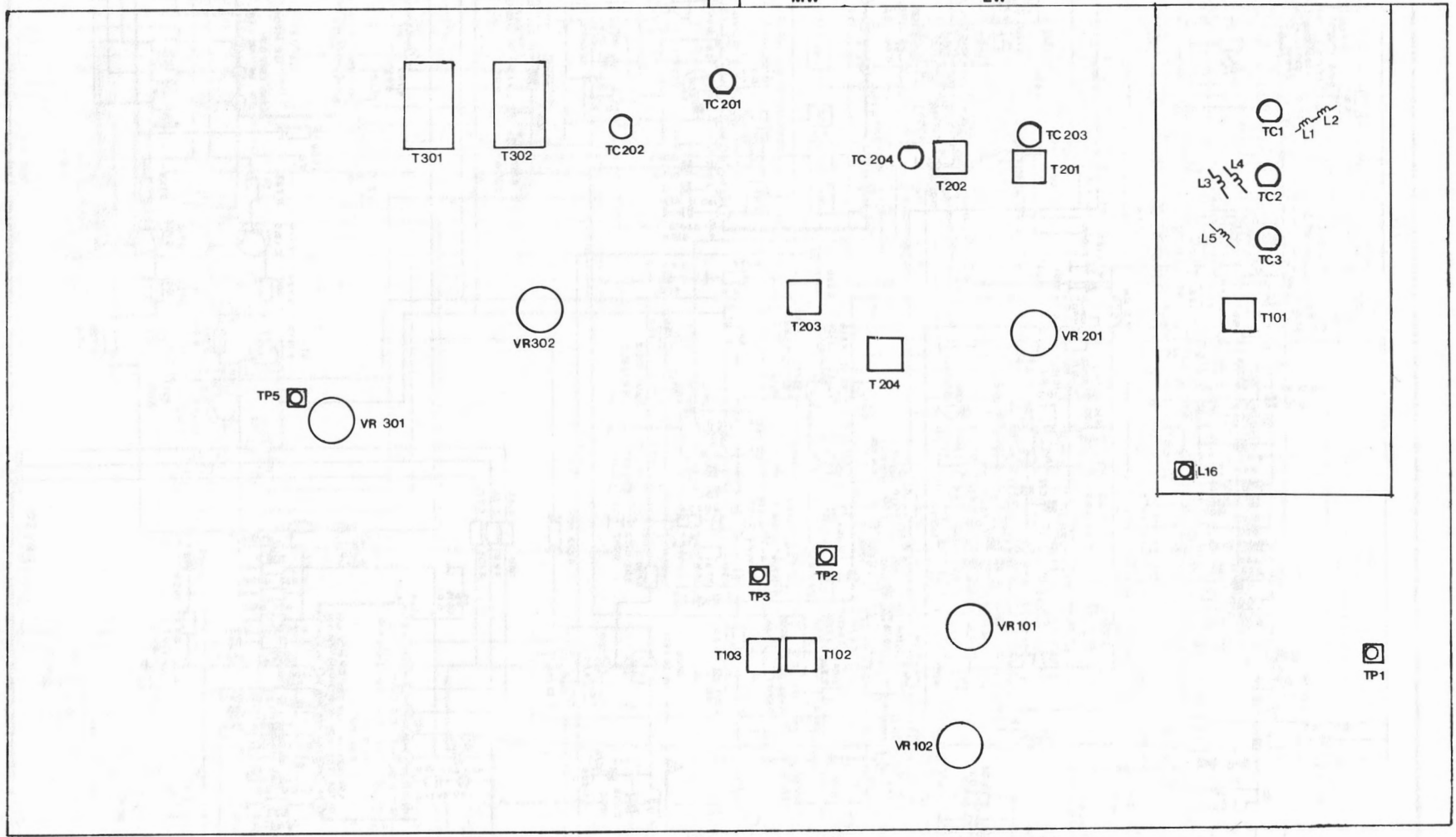
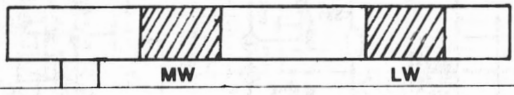

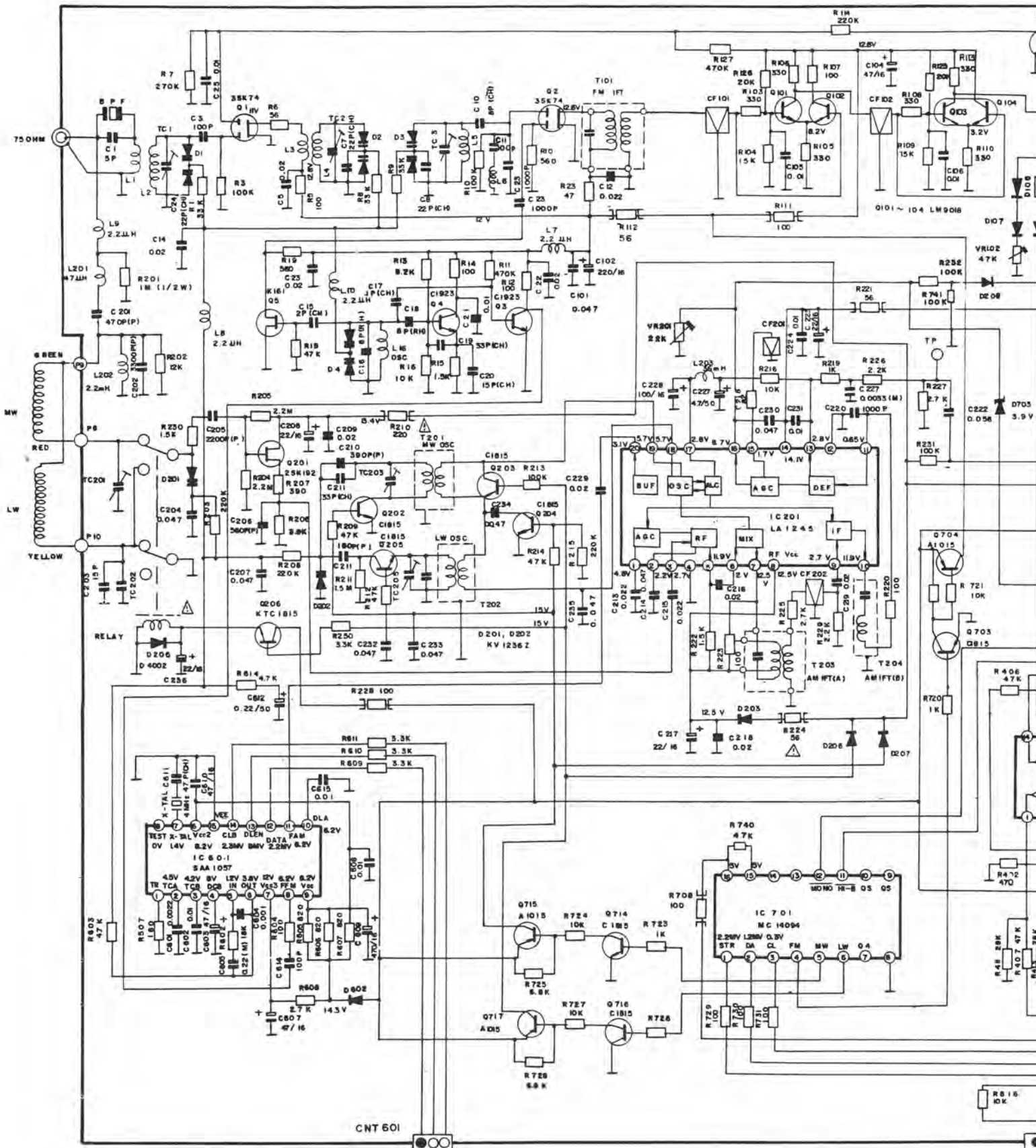





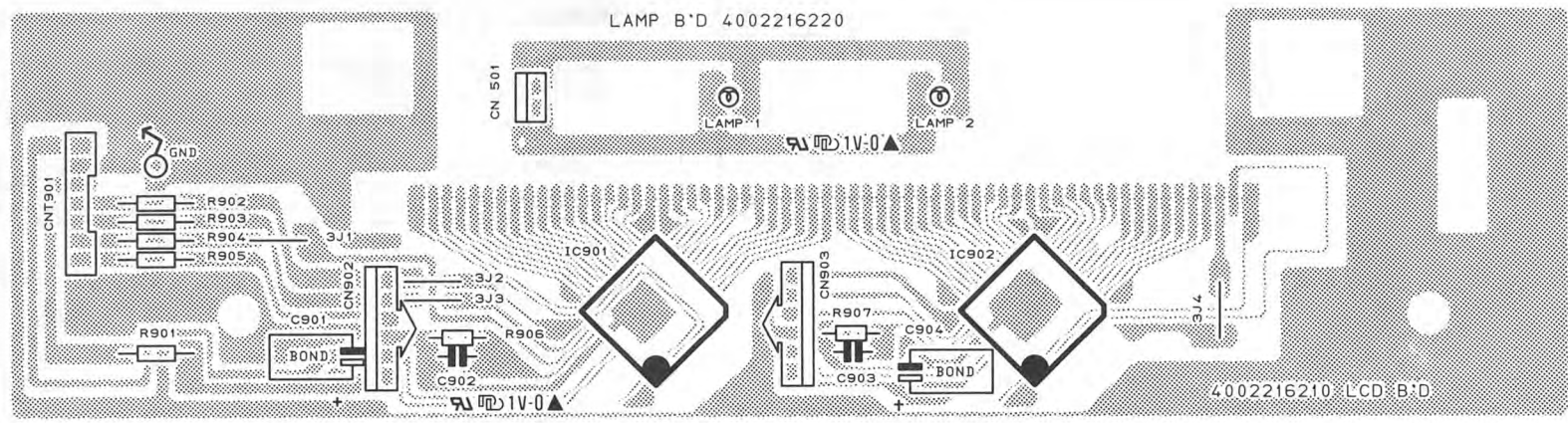
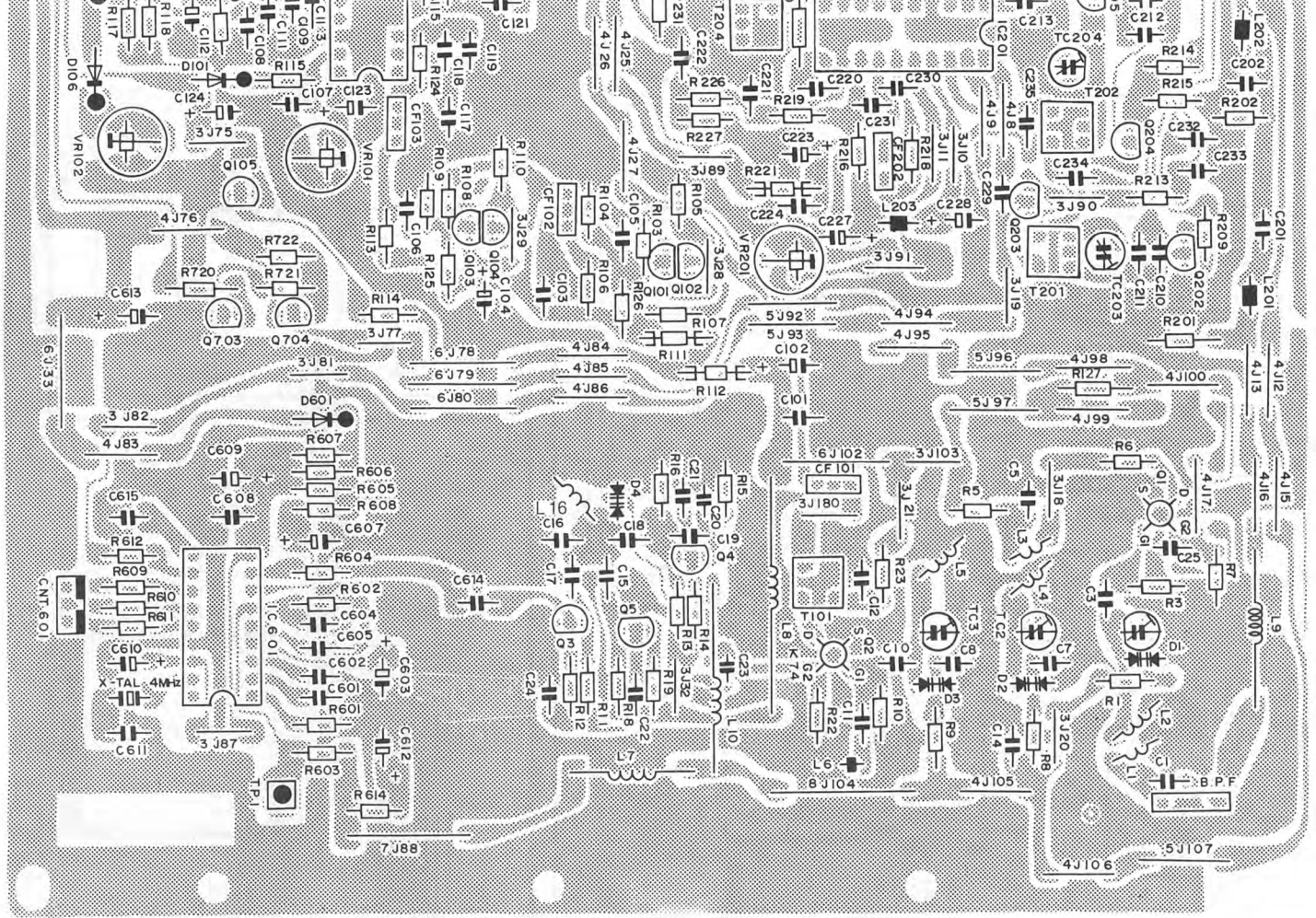
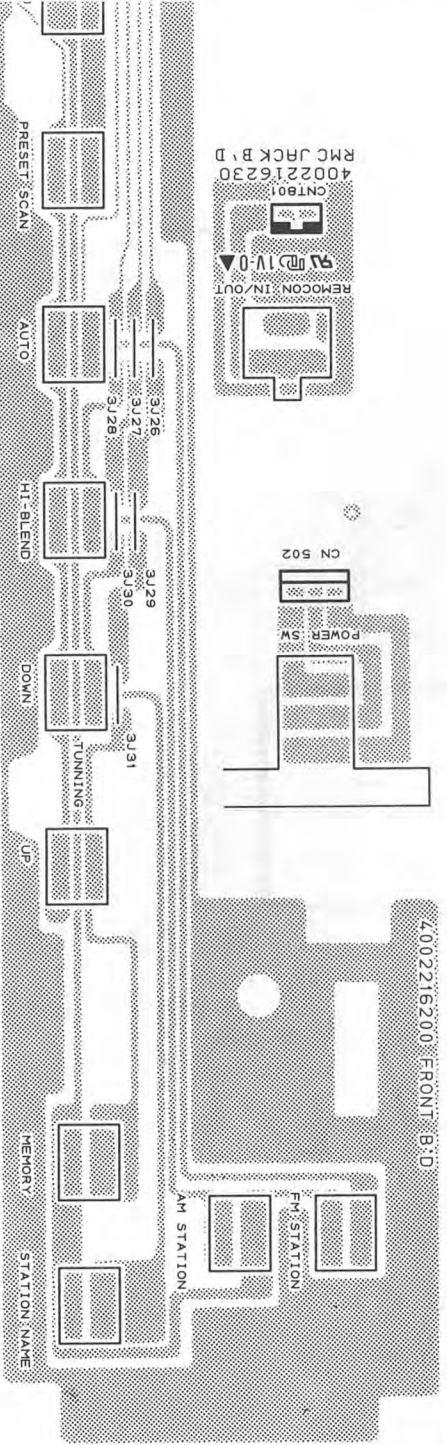

LCD-Platte  
LCD P.C.B.







Ersatzteile · Replacement parts · Pièces détachées · CT 7065

Pos.	Art.-Nr.	Bezeichnung
1	283 678	Gehäuseblech
2	286 915	Frontblende CT 7065
3	283 750	Dual-Zeichen
4	284 792	Fenster
6	283 665	Netztaсте
7	284 344	Taste A
8	284 314	Taste 2-fach
9	284 795	Taste 6-fach
10	286 916	Taste 1-5
11	286 917	Taste 6-10
15	280 197	Schalter
16	284 318	Schalter Power
18	284 786	Display LCD 8092 M1 J9
26	282 347	Cinchbuchse 1-fach
27	282 346	Antennenbuchse
38	283 710	Gerätefuß
42	286 918	Netztrafo
44	237 548	Kabeldurchführung
46	243 750	Netzkabel Europa
47	282 349	Antennenhalter
48	282 350	MW/LW Antenne
49	286 897	Remotebuchse
52	282 344	Lampe
53	286 898	Anschlußbuchse
54	282 523	Schraube 3×8
<b>Grundplatte</b>		
L 1	284 779	Spule FM
L 2	282 221	Spule
L 3	284 780	Spule FM RF
L 4	282 221	Spule
L 5	282 221	Spule
L 7	282 191	Spule 2,2 UH
bis		
L 9	282 191	Spule 2,2 UH
L 10	283 328	Spule FM OSC
L 101	282 194	Spule 20,8 UH
L 201	282 192	Spule 47 UH
L 202	282 195	Spule 2,2 MH
L 203	282 325	Spule 36 MH
T 101	284 781	Spule FM IFT
T 102	282 183	Spule
T 103	282 184	Spule
T 201	282 326	Spule
T 202	282 327	Spule
T 203	282 189	Spule
T 204	282 188	Spule
T 301	282 21	Spule
T 302	282 321	Spule
CF 101	284 782	Keramikfilter SFE 10,7 MS 3 GH
CF 102	284 783	Keramikfilter SFE 10,7 MK 1K
CF 103	284 783	Keramikfilter SFE 10,7 MK 1K
CF 201	282 198	Keramikfilter SFP 455
CF 202	284 784	Keramikfilter BFU 450 C
D 1	282 320	Diode KV 1310 A-3
bis		
2D 4	282 320	Diode KV 1310 A-3
D 101	223 906	Diode 1 N 4148
D 102	223 906	Diode 1 N 4148
D 106	223 906	Diode 1 N 4148
bis		
D 108	223 906	Diode 1 N 4148
D 201	282 223	Diode KV 1236
D 202	282 223	Diode KV 1236
D 203	223 906	Diode 1 N 4148
D 204	223 906	Diode 1 N 4148

Pos.	Art.-Nr.	Bezeichnung
D 205	226 501	Diode 1 N 4002
D 206	223 906	Diode 1 N 4148
bis		
D 208	223 906	Diode 1 N 4148
D 302	223 906	Diode 1 N 4148
D 508	226 501	Diode 1 N 4002
D 509	226 501	Diode 1 N 4002
D 601	223 906	Diode 1 N 4148
D 701	223 906	Diode 1 N 4148
D 702	223 906	Diode 1 N 4148
D 703	283 552	Diode DZ 5,6
D 801	282 063	Diode DZ 12 BM
D 805	283 552	Diode DZ 5,6
D 806	223 906	Diode 1 N 4148
D 807	282 062	Diode DZ 9,1 BM
IC 101	268 204	IC HA 12412
IC 201	282 167	IC LA 1245
IC 301	264 541	IC HA 12016
IC 401	261 352	IC LM 324
IC 501	283 679	IC GD 7815
IC 601	274 730	IC SAA 1057
IC 701	276 039	IC MC 14094 BCP
Q 1	282 210	Transistor 3 SK 74 L
Q 2	282 210	Transistor 3 SK 74 L
Q 3	282 171	Transistor KTC 1923 Y
Q 4	282 169	Transistor KTK 161 Y
Q 5	282 171	Transistor KTC 1923 Y
Q 101	282 172	Transistor LM 9018 F
bis		
Q 104	282 172	Transistor LM 9018 F
Q 105	282 076	Transistor KTC 1815 Y
Q 201	284 785	Transistor KTK 192
Q 202	282 076	Transistor KTC 1815 Y
Q 206	282 076	Transistor KTC 1815 Y
Q 511	283 667	Transistor 2 SD 2058 Y
Q 701	282 376	Transistor KTC 1815 Y
bis		
Q 703	282 376	Transistor KTC 1815 Y
Q 704	282 077	Transistor KTA 1015 Y
Q 706	282 076	Transistor KTC 1815 Y
Q 707	282 077	Transistor KTA 1015 Y
Q 708	282 077	Transistor KTA 1015 Y
Q 709	282 075	Transistor 2 SK 117 Y
Q 712	282 075	Transistor 2 SK 117 Y
Q 713	282 076	Transistor KTC 1815 Y
Q 714	282 076	Transistor KTC 1815 Y
Q 715	282 077	Transistor KTA 1015 Y
Q 716	282 076	Transistor KTC 1815 Y
Q 717	282 077	Transistor KTA 1015 Y
X 1	281 411	Quartz 4 MHz
RY 1	286 913	Relais
<b>Frontplatte</b>		
D 801	223 906	Diode 1 N 4148
bis		
D 804	223 906	Diode 1 N 4148
IC 801	284 788	IC UP DWP 500
IC 802	284 798	IC 24 CO 2
<b>LCD-Platte</b>		
IC 901	283 717	IC LC 7583
IC 902	283 717	IC LC 7583
LCD	284 786	Display LCD 8092 M1J9
Lamp 1	282 344	Lampe
Lamp 2	282 344	Lampe
	284 969	Bedienungsanleitung

Änderungen vorbehalten! Subject to change! Sous réserve de modification!

