

Schärke KG
 Elektrohaus
 Berliner Str. 13 Tel. (07721) 55041
 773 Villingen/Schwarzwald

CV 3510



Service-Anleitung Service Manual Instructions de Service

Download from www.dual.de
 Not for commercial use

Technische Daten (typische Werte)	Technical Data (typical value)	Caractéristiques techniques (valeur caractéristiques)	
Ausgangsleistung (DIN / 8 Ω) Musikleistung Sinus-Dauerleistung	Rated output (DIN / 8 Ω) Music power Rms continuous power output	Puissance de sortie (DIN / 8 Ω) Puissance musicale Puissance efficace	2 × 50 Watt 2 × 35 Watt
Klirrfaktor bis 2 × 20 Watt, 1000 Hz	Harmonic distortion up to 2 × 20 W, 1000 Hz	Facteur de distortion jusqu'à 2 × 20 watts, 1000 Hz	< 0,04 %
Leistungsbandbreite nach DIN 45 500	Power bandwidth Complying with DIN 45 500	Réponse en puissance selon DIN 45 500	10 Hz – 40 kHz
Übertragungsbereich (Baß- und Höhenregler in Mittenstellung) Phono-Eingang nach RIAA	Frequency response (bass and treble controls at center positions) Phono complying with RIAA	Bande passante (Régulateurs des basses et des aigus en position centrale) Phono selon RIAA	20 Hz – 20 kHz ± 1 dB 15 Hz – 40 kHz ± 3 dB 20 Hz – 20 kHz ± 2 dB
Eingänge Tuner, Tape 1, Tape 2 Phono	Inputs Tuner, Tape 1, Tape 2 Phono	Entrées Tuner, Tape 1, Tape 2 Phono	150 mV, 47 kΩ 2,5 mV, 47 kΩ
Ausgänge 2 Druckklemmen für zwei Lautsprecher- paare, Ausgang A und Ausgang B schaltbar 1 Koaxial-Buchse 1/4 inch für Kopfhörer 1 Line-Ausgang an Tape 1 1 Line-Ausgang an Tape 2 (Ri = 470 Ω)	Outputs 2 press-type terminal strips for two sets of speakers, output A and output B switched 1 coaxial jack 1/4 inch for headphone 1 Line output to Tape 1 1 Line output to Tape 2 (Ri = 470 Ω)	Sorties 2 barres a ressort pour deux paires de hauts-parleurs, sortie A et sortie B commutables 1 prise coaxiale de 1/4 inch pour le raccordement du casque-écouter 1 sortie Line sur la prise Tape 1 1 sortie Line sur la prise Tape 2 (Ri = 470 Ω)	8–16 Ohm
Fremdspannungsabstand Spitzenwert über Fremdspannungsfilter (DIN 45 405) bezogen auf Nennleistung Tuner, Tape, Monitor Phono	Unweighted signal-to-noise ratio Peak value via external voltage filter (DIN 45 405) related to nominal output Tuner, Tape, Monitor Phono	Rapport signal/bruit non-pondéré Valeur de pointe après le filtre de tension non pondérée (DIN 45 405) ramené à la puissance nominale Tuner, Tape, Monitor Phono	80 dB 62 dB
Geräuschspannung gemessen nach IHF bewertet mit A-Filter (RMS) bezogen auf Nennleistung	Noise voltage measured in accordance with IHF weighted with A-filter (RMS) in relation to rated power	Tension perturbatrice mesurée selon IHF pondérée avec filtre A (RMS), ramenée à la puissance nominale	90 dB 75 dB
Übersprechdämpfung bei 1000 Hz zwischen den Kanälen zwischen den Eingängen	Crosstalk attenuation at 1000 Hz between the channels between the inputs	Affaiblissement de diaphonie pour 1000 Hz Entre les canaux Entre les entrées	60 dB 65 dB
Leistungsaufnahme (maximal)	Power consumption (maximum)	Puissance absorbée (maximale)	170 Watt
Netzspannung	Line voltage	Tension du réseau	220 Volt

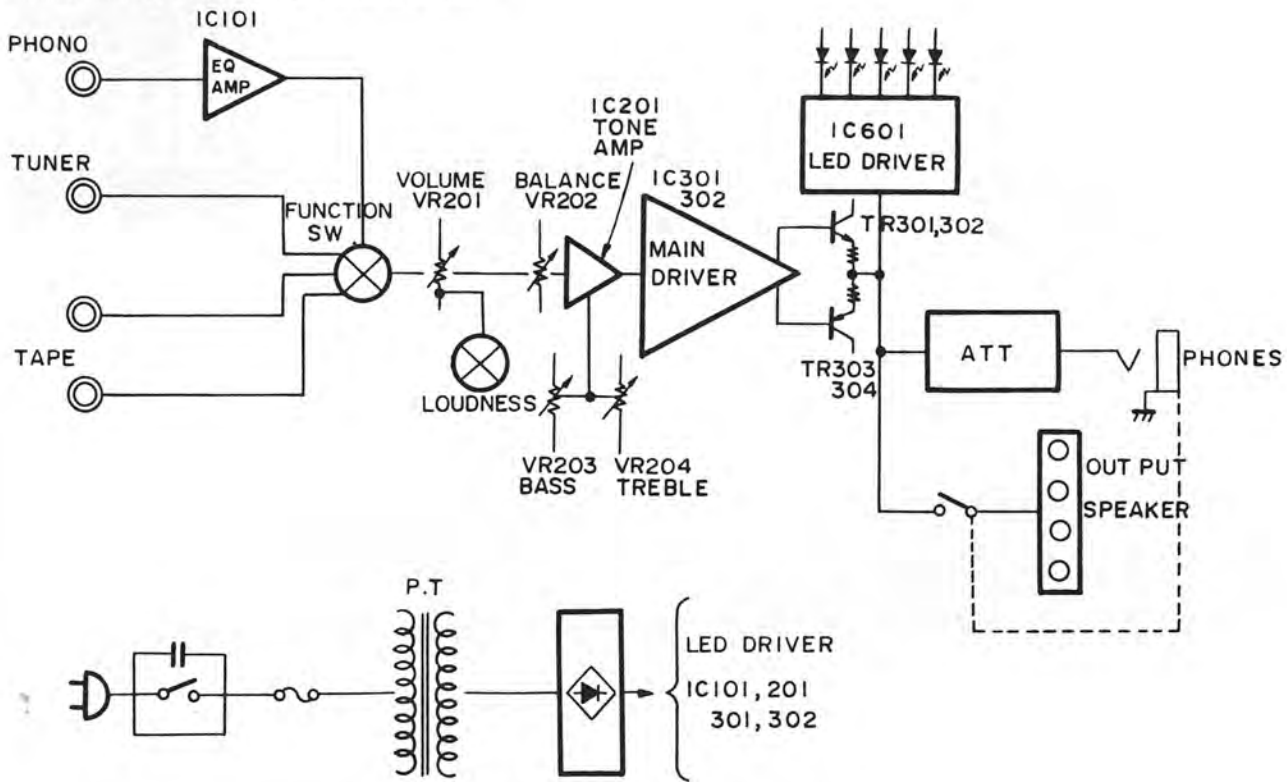

Abgleichanleitung CV 3510 · Adjustment instructions CV 3510

Signalquelle Signal source	Einstellung Signalquelle Signal source adjustment	Einstellung Gerät Unit adjustment	Anzeigegegerät Anschluß Indicator connection	Abgleichposition Adjustment position	Abgleich, Bemerkung Adjustment, Remarks
Ruhestrom · Quiescent current					
		Power: ON Tuner: ON Volume: Minimum	DC-Voltmeter an DC-voltmeter to TP303/T301 TP304/TP302 nach 30 sec. after 30 sec.	VR 303 VR 304	auf 2,5 mV DC einstellen adjust to 2,5 mV DC

Abgleichpositionen / Alignment positions / Position d'alignement

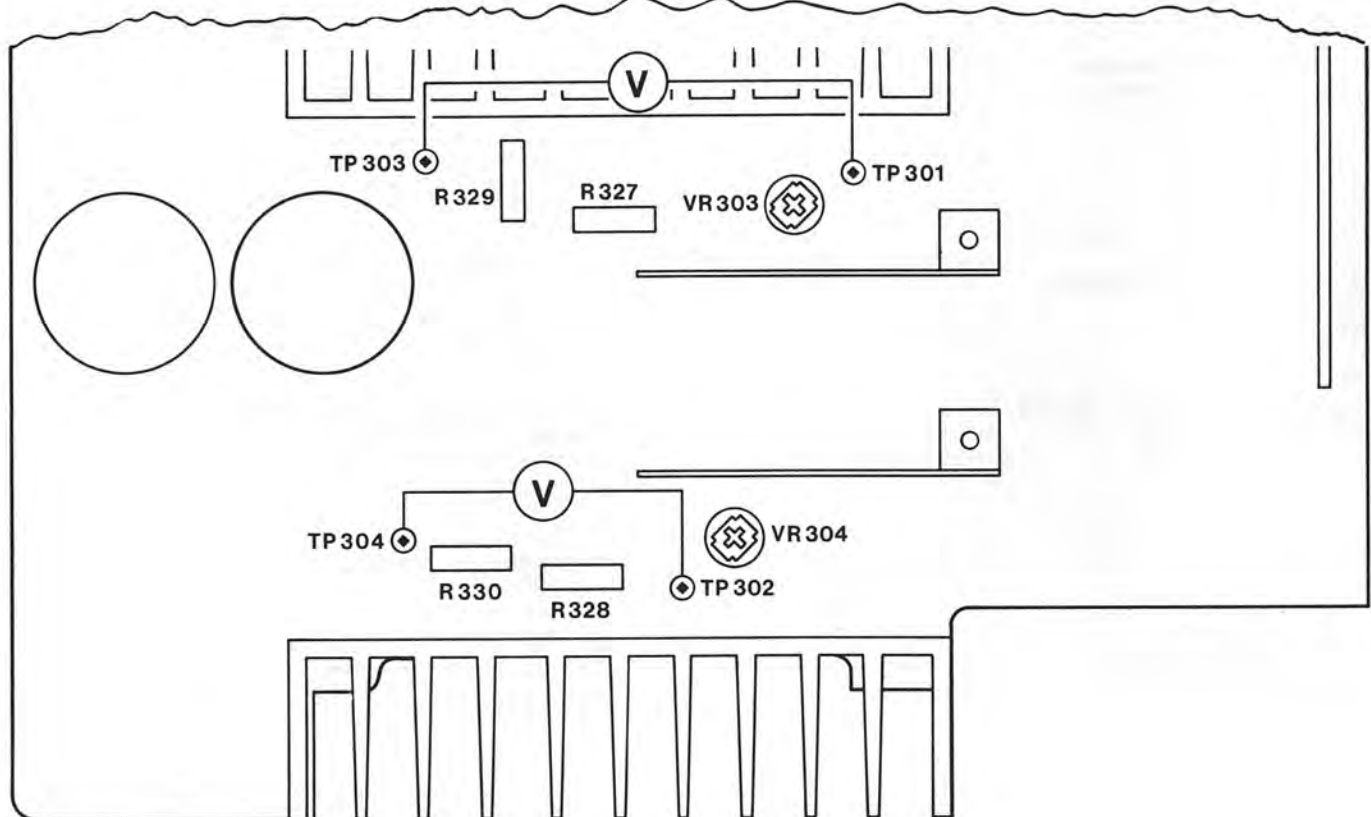

Schaltbild / Wiring diagram / Schéma d'électrique

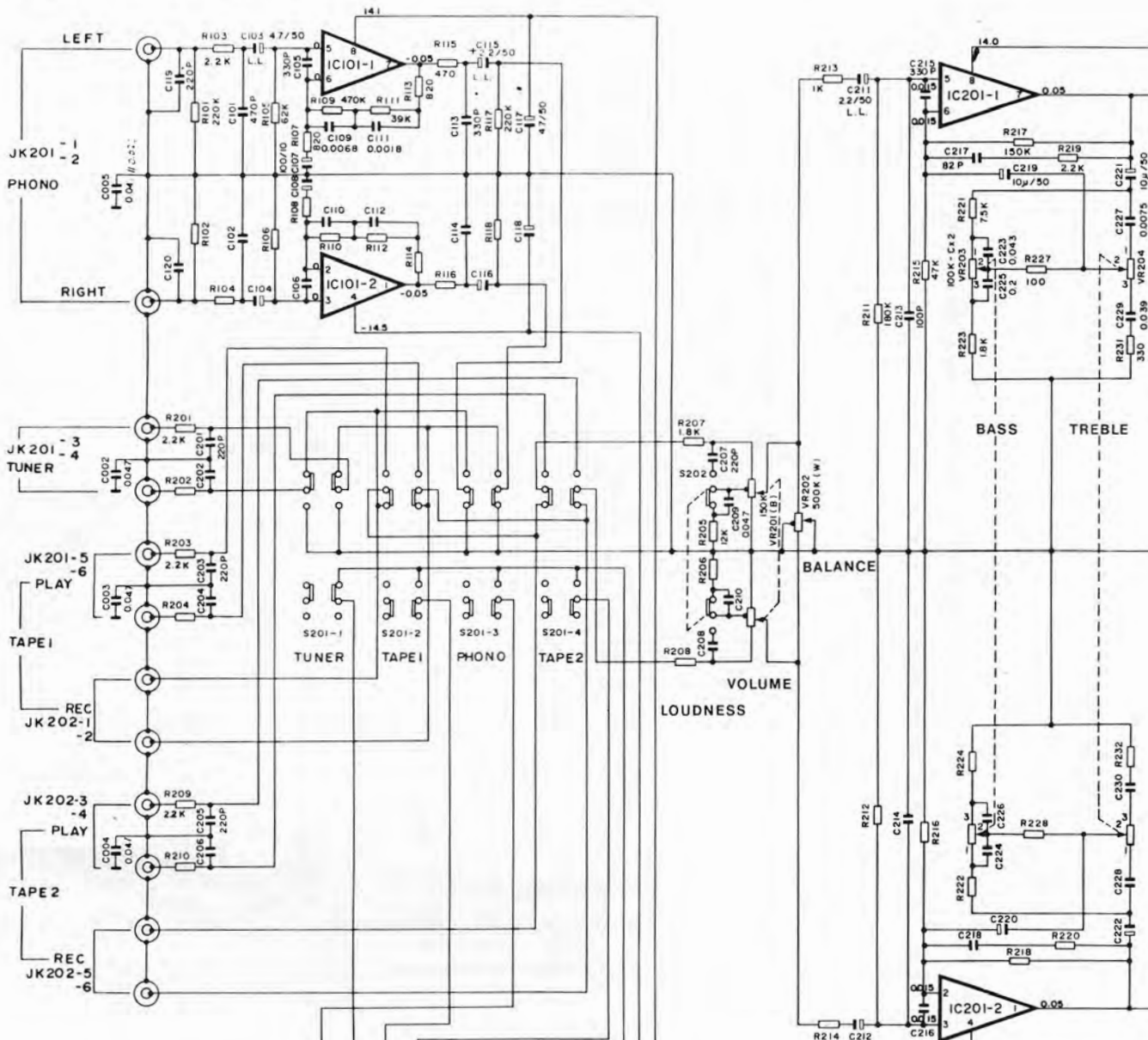

- IC 101 M5218L
- IC 201 M5218L
- IC 301, 302 μ PC1225H
- IC 601, 602 AN6875

D407 ~ D410 TLG205

R415 D406
1.2K(1W) RD4.7JB

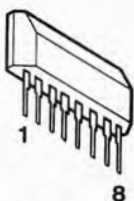
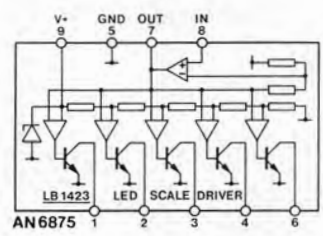
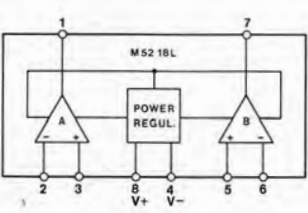

M 5218 L

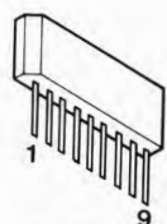

AN 6875

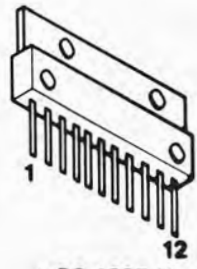

μ PC 1225 H

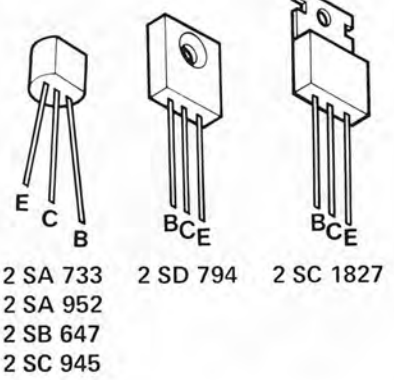
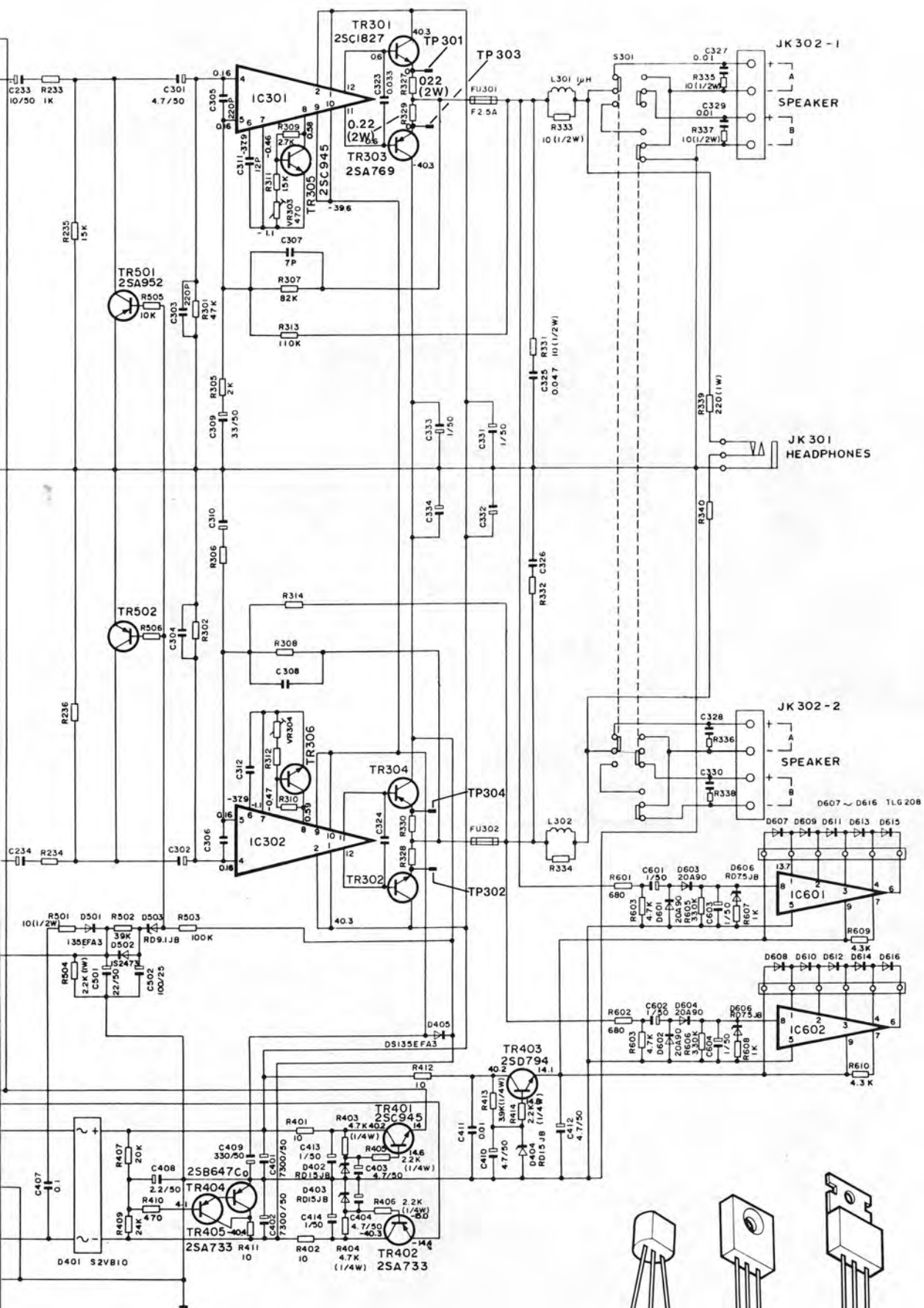

- 2 SA 733
- 2 SA 952
- 2 SB 647
- 2 SC 945
- 2 SD 794
- 2 SC 1827

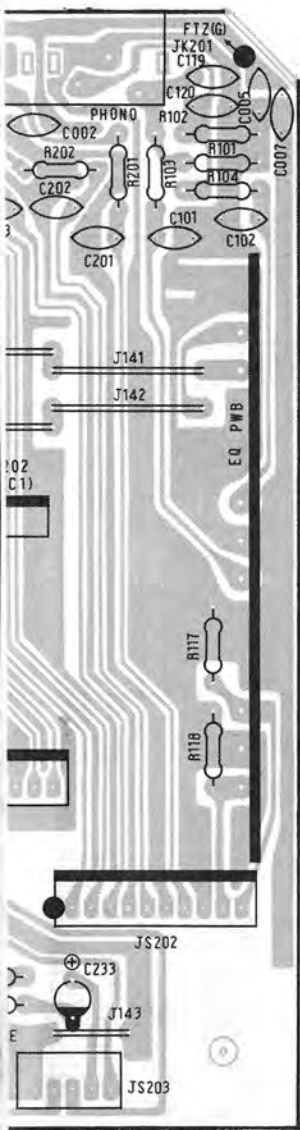

EQ-platte / EQ board / Plaque de EQ B

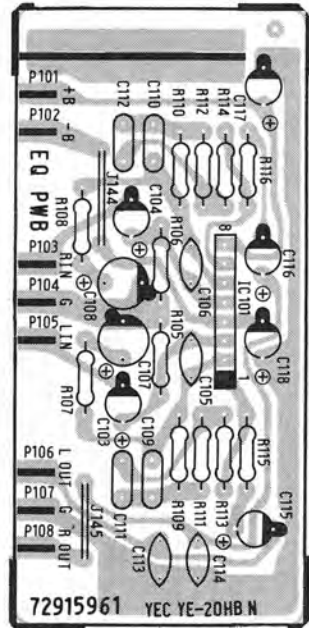

LED-platte / LED board / Plaque de LED L

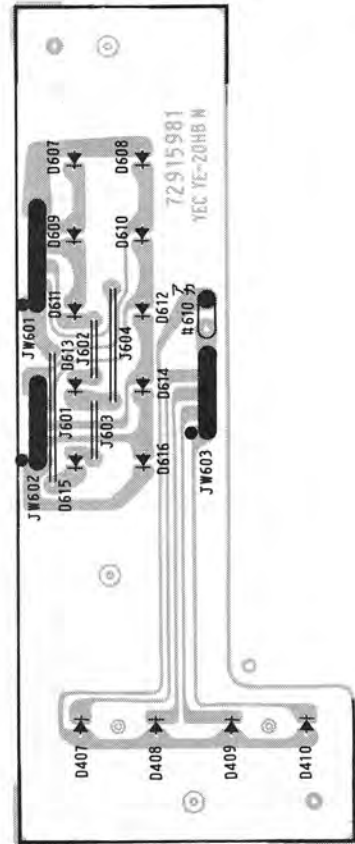

L = Leiterseite / Wiring side / Côté de conducteur

B = Bestückungsseite / Equipment side / Côté de composants

Platte / Control board / Plaque de Contrôle B

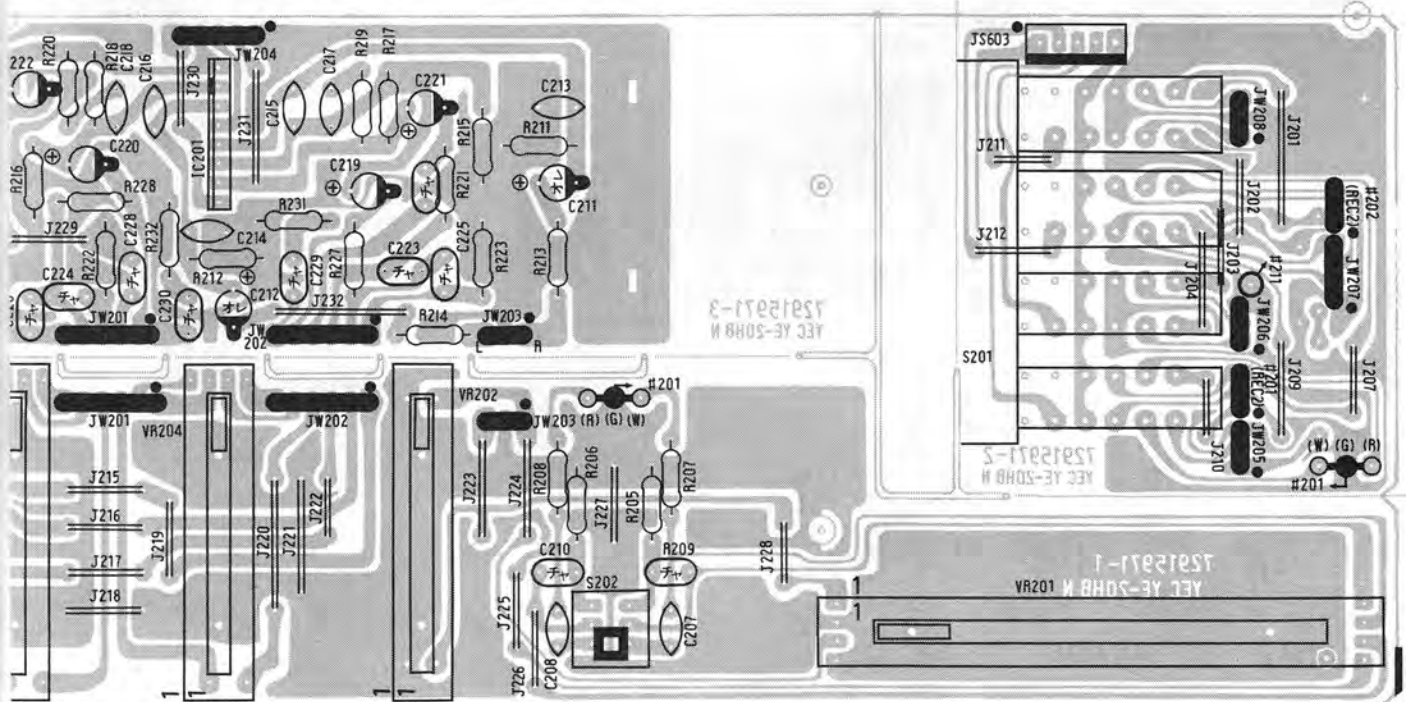

Ersatzteile · Replacement parts · Pièces détachée · CV 3510

Pos.	Art.-Nr.	Stck	Bezeichnung
1	275 141	1	Gehäuseblech
4	275 148	1	Knopf Speaker A
5	275 149	1	Knopf Speaker B
6	275 145	3	Schiebeknopf
7	275 147	1	Knopf (Loudness)
8	275 146	1	Knopf (Volume)
9	275 140	1	Frontblende
10	275 144	1	Powerknopf
11	275 205	1	Adapter
15	275 150	1	Taste (Phono)
16	275 151	1	Taste (Tuner)
17	275 152	1	Taste (TAPE 1)
18	275 153	1	Taste (TAPE 2)
22	275 204	4	Gerätefuß
26	275 206	2	Adapter L
27	275 207	2	Adapter S
40	275 121	1	Netztrafo
41	243 750	1	Netzkabel Europa
42	275 139	2	Cinchbuchsen
43	275 137	1	Kopfhörerbuchse
44	275 138	1	Lautsprecheranschlußklemmen
50	275 126	1	Grundplatte kpl.
55	275 127	1	LED-Platte kpl.
60	275 128	1	Ausgang-Platte kpl.
65	275 129	1	Control-Platte kpl.
70	275 130	1	EQ-Platte kpl.
75	275 131	1	Netzschalter-Platte kpl.
L 301	275 132	2	Spule
L 302	275 132	2	Spule
S 1	275 134	1	Netzschalter
S 201	275 135	1	Schalter (Tuner-Tape 2)
S 202	275 133	1	Schalter (Loudness)
S 301	275 136	1	Schalter (Speaker)
FU 1	209 711	1	G-Schmelzeinsatz T 1,25 A
FU 301	227 724	1	G-Schmelzeinsatz F 2,5 A
FU 302	227 724	1	G-Schmelzeinsatz F 2,5 A
C 401	277 051	1	Kondensator 7300 UF/50 V
C 402	277 051	1	Kondensator 7300 UF/50 V
D 401	275 203	1	Gleichrichter
D 402	274 959	3	Diode RD 15 JB
D 403	274 959	3	Diode RD 15 JB
D 404	274 959	3	Diode RD 15 JB
D 405	268 705	2	Diode DS 135 FA 3
D 406	275 543	1	Diode RD 4,7 J
D 407	274 957	4	LED TLG 205

Pos.	Art.-Nr.	Stck	Bezeichnung
D 408	274 957	4	LED TLG 205
D 409	274 957	4	LED TLG 205
D 410	274 957	4	LED TLG 205
D 501	268 705	2	Diode DS 135 FA 3
D 502	263 034	2	Diode DD 1 S 2473
D 503	275 120	1	Diode RD 9
D 601	275 202	4	Diode 20 A 90
D 602	275 202	4	Diode 20 A 90
D 603	275 202	4	Diode 20 A 90
D 604	275 202	4	Diode 20 A 90
D 607	269 495	10	LED TLG 208
D 608	269 495	10	LED TLG 208
D 609	269 495	10	LED TLG 208
D 610	269 495	10	LED TLG 208
D 611	269 495	10	LED TLG 208
D 612	269 495	10	LED TLG 208
D 613	269 495	10	LED TLG 208
D 614	269 495	10	LED TLG 208
D 615	269 495	10	LED TLG 208
D 616	269 495	10	LED TLG 208
IC 101	274 955	2	IC M 5218 L
IC 201	274 955	2	IC M 5218 L
IC 301	274 956	2	IC UPC 1225 H
IC 302	274 956	2	IC UPC 1225 H
IC 601	274 954	2	IC AN 6875
IC 602	274 954	2	IC AN 6875
TR 301	272 747	2	Transistor 2 SC 1827 Y
TR 302	272 747	2	Transistor 2 SC 1827 Y
TR 303	266 911	2	Transistor 2 SA-7690
TR 304	266 911	2	Transistor 2 SA-7690
TR 305	263 148	3	Transistor 2 SC 945 Q
TR 306	263 148	3	Transistor 2 SC 945 Q
TR 401	263 148	3	Transistor 2 SC 945 Q
TR 402	263 142	2	Transistor 2 SA 733 Q
TR 403	275 201	1	Transistor 2 SD 794 Q
TR 404	266 946	1	Transistor 2 SB 647 C
TR 405	263 142	2	Transistor 2 SA 733 Q
TR 502	275 200	2	Transistor 2 SA 952 K
VR 201	275 544	1	Steller 100 kΩ
VR 202	275 122	1	Steller
VR 203	275 123	2	Steller
VR 204	275 123	2	Steller
VR 303	275 125	2	Steller 470 k
VR 304	275 125	2	Steller 470 k
TR 501	275 200	2	Transistor 2 SA 952 K
	275 154	1	Verpackungskarton
	275 208	1	Bedienungsanleitung

Änderungen vorbehalten / Alteration reserved / Sous réserve de modifications